

## Anybus<sup>®</sup> Communicator<sup>™</sup> - PROFIBUS to Modbus RTU/Serial

### USER MANUAL

SCM-1202-177  
Version 1.24  
Publication date 2024-05-02



## Important User Information

### **Disclaimer**

The information in this document is for informational purposes only. Please inform HMS Networks of any inaccuracies or omissions found in this document. HMS Networks disclaims any responsibility or liability for any errors that may appear in this document.

HMS Networks reserves the right to modify its products in line with its policy of continuous product development. The information in this document shall therefore not be construed as a commitment on the part of HMS Networks and is subject to change without notice. HMS Networks makes no commitment to update or keep current the information in this document.

The data, examples and illustrations found in this document are included for illustrative purposes and are only intended to help improve understanding of the functionality and handling of the product. In view of the wide range of possible applications of the product, and because of the many variables and requirements associated with any particular implementation, HMS Networks cannot assume responsibility or liability for actual use based on the data, examples or illustrations included in this document nor for any damages incurred during installation of the product. Those responsible for the use of the product must acquire sufficient knowledge in order to ensure that the product is used correctly in their specific application and that the application meets all performance and safety requirements including any applicable laws, regulations, codes and standards. Further, HMS Networks will under no circumstances assume liability or responsibility for any problems that may arise as a result from the use of undocumented features or functional side effects found outside the documented scope of the product. The effects caused by any direct or indirect use of such aspects of the product are undefined and may include e.g. compatibility issues and stability issues.

Copyright © 2024 HMS Networks

### **Contact Information**

Postal address:  
Box 4126  
300 04 Halmstad, Sweden

E-Mail: [info@hms.se](mailto:info@hms.se)

# Table of Contents

<b>1. Preface</b>	<b>1</b>
1.1. About This Document	1
1.2. Document Conventions	1
1.3. Trademarks	2
<b>2. Safety</b>	<b>3</b>
2.1. Intended Use	3
2.2. General Safety	3
<b>3. Cybersecurity</b>	<b>4</b>
3.1. General Cybersecurity	4
3.2. Security Advisories	4
3.3. How to Report a Vulnerability	4
3.4. Product Cybersecurity Context	5
3.4.1. Security Defense in Depth Strategy	5
3.4.2. Purdue Model	6
<b>4. Preparation</b>	<b>7</b>
4.1. Cabling	7
4.2. System Requirements	7
4.2.1. Supported Operating Systems	7
4.2.2. Supported Web Browsers	7
4.3. Mechanical Tools and Equipment	7
4.4. Support and Resources	7
4.5. HMS Software Applications	8
4.6. Third-Party Software Applications	8
4.7. Software License Information	8
<b>5. About Anybus Communicator</b>	<b>9</b>
5.1. Serial Protocol Communication	9
5.1.1. Serial Protocol Types	9
5.1.2. Serial Protocol Building Blocks	10
5.2. How the Communication Works	13
5.3. How the Data Exchange Works	15
5.4. Data Integrity	15
<b>6. Installation</b>	<b>16</b>
6.1. External Parts	16
6.2. Connector Port Guide	17
6.3. DIN Rail Mounting	18
6.4. Connect to PROFIBUS Network	19
6.5. Connect to Serial RS232/RS485 Subnetwork	20
6.6. Rotary Switch Settings	22
6.6.1. Rotary Switches Default Setting	22
6.6.2. Set a Node Address with Rotary Switches	23
6.7. Connect to Power	27
6.8. Security Switch	28
6.9. Lock the Cables	30
6.10. DIN Rail Demount	31
<b>7. Configuration Quick Guide</b>	<b>33</b>
7.1. Prepare Configuration	33

7.2. Setup New Configuration .....	36
7.3. PLC Configuration .....	39
7.4. Verify Operation .....	41
<b>8. Communicator Configuration .....</b>	<b>43</b>
8.1. Connect the Communicator .....	43
8.2. Access the Built-In Web Interface from HMS IPconfig .....	44
8.3. Access the Built-In Web Interface from a Web Browser .....	46
8.4. Communicator Built-In Web Interface Overview .....	47
8.5. General Subnetwork Settings .....	48
8.5.1. Communication Serial Protocol .....	48
8.5.2. Communication Basic Settings .....	49
8.5.3. Communication Advanced Settings .....	51
8.6. About Transaction Templates .....	57
8.6.1. Transaction Template Example .....	57
8.6.2. Transaction Template Types .....	59
8.6.3. Frame Field Types .....	61
8.7. Build Transaction Template .....	63
8.7.1. Add Transaction Template .....	63
8.7.2. Add Frame Fields .....	67
8.7.3. Configure Frame Field Settings .....	69
8.7.4. Data Delimiter and Subnet Delimiter Options .....	72
8.7.5. Store Transaction Templates .....	75
8.8. Nodes and Transactions .....	76
8.8.1. Node and Broadcast Node .....	76
8.8.2. Add Node .....	77
8.8.3. Import Node Settings From Other Communicator Unit .....	78
8.8.4. Import Transaction Template From Other Communicator Unit .....	82
8.8.5. Node Settings .....	85
8.8.6. Add Transactions .....	86
8.8.7. Transaction Settings .....	89
8.8.8. Activate/Deactivate Transaction .....	91
8.8.9. Duplicate Transaction .....	91
8.8.10. Delete Transaction .....	92
8.9. PROFIBUS Network Settings .....	93
8.9.1. To Use Automatic I/O Sizes .....	93
8.9.2. To Configure I/O Sizes Manually .....	93
8.9.3. I/O Size Restrictions for Allow Any Module Mapping .....	94
8.9.4. PROFIBUS Address Settings .....	95
8.10. PROFIBUS Advanced Settings .....	96
8.10.1. Legacy Mode .....	96
8.10.2. Allow Any Module Mapping .....	97
8.11. I/O Configuration .....	99
8.11.1. Optimize the I/O Configuration .....	100
8.11.2. Map Area Transactions Order .....	101
8.11.3. Map Area .....	102
8.11.4. Trigger Byte .....	102
8.11.5. Endian Swap .....	103
8.11.6. Offline Option .....	105
8.11.7. Live List .....	106
8.11.8. Data Exchange Control .....	107
8.12. Configuration Notes .....	108
8.12.1. Add Configuration Note .....	108
8.12.2. View and Edit Configuration Notes .....	110
8.13. Apply Configuration .....	111

8.14. To Use an Existing Configuration .....	112
8.15. To Use a Communicator Classic Configuration .....	113
<b>9. PLC Configuration .....</b>	<b>115</b>
9.1. PLC Device Security .....	115
9.2. Export I/O Configuration .....	115
9.3. Export Product GSD File .....	116
9.4. How to Use GSD File Modules .....	117
<b>10. Verify Operation .....</b>	<b>119</b>
10.1. Communicator Status Monitor .....	119
10.2. Communicator LED Indicators .....	121
<b>11. Use Cases .....</b>	<b>122</b>
11.1. Temperature Regulator - Modbus RTU Use Case .....	122
11.1.1. About the Use Case .....	122
11.1.2. Before You Begin .....	122
11.1.3. Choose Serial Protocol Type .....	123
11.1.4. Setup Serial Communication .....	123
11.1.5. Setup the Node .....	124
11.1.6. Setup the Transactions .....	125
11.1.7. Check the I/O Configuration .....	127
11.2. AC Motor Drive - Custom Request/Response Use Case .....	128
11.2.1. About the Use Case .....	128
11.2.2. Before You Begin .....	128
11.2.3. Choose Serial Protocol Type .....	129
11.2.4. Setup Serial Communication .....	129
11.2.5. Create Transaction Templates .....	130
11.2.6. Setup Node and Transactions .....	134
11.2.7. Check the I/O Configuration .....	135
11.3. Barcode Scanner - Custom Produce/Consume Use Case .....	136
11.3.1. About the Use Case .....	136
11.3.2. Before You Begin .....	136
11.3.3. Choose Serial Protocol Type .....	137
11.3.4. Setup Serial Communication .....	137
11.3.5. Create Transaction Templates .....	138
11.3.6. Setup Node and Transactions .....	140
11.3.7. Check the I/O Configuration .....	141
<b>12. Maintenance .....</b>	<b>142</b>
12.1. Action on Fatal Error .....	142
12.2. Configuration Port IP Settings .....	143
12.3. Configuration File Handling .....	144
12.3.1. Export Configuration .....	144
12.3.2. Import Configuration .....	145
12.4. Clear and Revert Configuration .....	146
12.5. Firmware Management .....	147
12.5.1. View the Firmware Version .....	147
12.5.2. Firmware and Configuration Compatibility .....	147
12.5.3. Firmware File Validation .....	147
12.5.4. Update Firmware .....	148
12.6. Change Language .....	149
<b>13. Troubleshooting .....</b>	<b>150</b>
13.1. Diagnostics .....	150

13.1.1. Serial RS-232/485 Data Monitor .....	150
13.1.2. I/O Data .....	151
13.1.3. Event Log .....	152
13.1.4. LED Status .....	153
13.2. Reset to Factory Settings .....	154
13.3. Firmware Upgrade Error Management .....	156
13.4. Support .....	158
13.4.1. Support Package .....	158
<b>14. Technical Data .....</b>	<b>159</b>
14.1. Technical Specifications .....	159
<b>15. End Product Life Cycle .....</b>	<b>160</b>
15.1. Secure Data Disposal .....	160
<b>16. Reference Guides .....</b>	<b>161</b>
16.1. About Input Registers and Holding Registers .....	161
16.2. Modbus Data Model .....	161
16.3. Modbus Transactions .....	161
16.4. Modbus Exception Codes .....	162
16.5. ASCII Table .....	162
16.6. RS232/RS485 Electrical Connection .....	163
16.6.1. RS485 Typical Connection .....	163
16.6.2. RS232 Typical Connection .....	163

# 1. Preface

## 1.1. About This Document

This document describes how to install and configure Anybus® Communicator™.

For additional documentation and software downloads, FAQs, troubleshooting guides and technical support, please visit [www.anybus.com/support](http://www.anybus.com/support).

## 1.2. Document Conventions

### Lists

Numbered lists indicate tasks that should be carried out in sequence:

1. First do this
2. Then do this

Bulleted lists are used for:

- Tasks that can be carried out in any order
- Itemized information

### User Interaction Elements

User interaction elements (buttons etc.) are indicated with bold text.

### Program Code and Scripts

```
Program code and script examples
```

### Cross-References and Links

Cross-reference within this document: [Document Conventions \(page 1\)](#)

External link (URL): [www.anybus.com](http://www.anybus.com)

### Safety Symbols



#### DANGER

Instructions that must be followed to avoid an imminently hazardous situation which, if not avoided, will result in death or serious injury.



#### WARNING

Instructions that must be followed to avoid a potential hazardous situation that, if not avoided, could result in death or serious injury.



#### CAUTION

Instruction that must be followed to avoid a potential hazardous situation that, if not avoided, could result in minor or moderate injury.



#### IMPORTANT

Instruction that must be followed to avoid a risk of reduced functionality and/or damage to the equipment, or to avoid a network security risk.

## Information Symbols

**NOTE**

Additional information which may facilitate installation and/or operation.

**TIP**

Helpful advice and suggestions.

## 1.3. Trademarks

Anybus® is a registered trademark of HMS Networks.

All other trademarks are the property of their respective holders.

## 2. Safety

### 2.1. Intended Use

The intended use of this equipment is as a communication interface and gateway.

The equipment receives and transmits data on various physical layers and connection types.

If this equipment is used in a manner not specified by the manufacturer, the protection provided by the equipment may be impaired.

### 2.2. General Safety

**CAUTION**

Ensure that the power supply is turned off before connecting it to the equipment.

**CAUTION**

This equipment contains parts that can be damaged by electrostatic discharge (ESD). Use ESD prevention measures to avoid damage.

**CAUTION**

To avoid system damage, the equipment should be connected to ground.

**IMPORTANT**

Using the wrong type of power supply can damage the equipment. Ensure that the power supply is connected properly and of the recommended type.

## 3. Cybersecurity

### 3.1. General Cybersecurity

**IMPORTANT**

It is important to maintain the cybersecurity of the Communicator.

Before connecting the Communicator to a PLC, ensure the PLC is configured and installed in accordance with the PLC supplier hardening guidelines.

**IMPORTANT**

To physically secure networks and equipment and to prevent unauthorized access, it is recommended to install the equipment in a locked environment.

**IMPORTANT**

After completing the configuration of the Communicator, lock the security switch to prevent unauthorized access to the Communicator built-in web interface.

**IMPORTANT**

To avoid exposure of sensitive data, always perform a factory reset before decommissioning the equipment.

Factory reset will reset any on site made configuration changes and set the Communicator to the same state as leaving HMS production.

See [Reset to Factory Settings \(page 154\)](#).

### 3.2. Security Advisories

For cybersecurity reasons, stay informed about new vulnerabilities and follow the recommended actions.

HMS Networks Security Advisories includes information about our product vulnerabilities and available solutions.

You find our Safety Advisories at [www.hms-networks.com/cybersecurity/security-advisories](http://www.hms-networks.com/cybersecurity/security-advisories).

### 3.3. How to Report a Vulnerability

HMS Networks place the utmost importance on the security of our products and systems, however, despite all the measures we take, it cannot be excluded that vulnerabilities persist.

To report a potential vulnerability in an HMS product or service, please visit [www.hms-networks.com/cybersecurity/report-a-vulnerability](http://www.hms-networks.com/cybersecurity/report-a-vulnerability) and follow the instructions.

## 3.4. Product Cybersecurity Context

### 3.4.1. Security Defense in Depth Strategy

The defense in depth strategy of the Communicator includes the following security measures:

- Secure Boot: Security standard used to ensure that the Communicator boots using only software that is trusted by HMS Networks.
- Signed firmware: HMS Networks delivers digitally signed firmware. Before the firmware file is imported into the Communicator, the firmware upgrade function performs a validation of the file, to ensure that is authentic.
- Security switch: Used to lock unauthorized access to the Communicator built-in web interface.
- The Communicator is intended to be installed in a Process Control Network (PCN) environment. See Level 1 in the [Purdue Model \(page 6\)](#).
- To physically secure networks and equipment and to prevent unauthorized access, the Communicator is intended to be installed in a locked environment.

### 3.4.2. Purdue Model

The Communicator is intended to be part of the process control network in Level 1 (E), to enable communication between PLCs or between a PLC and peripheral devices.

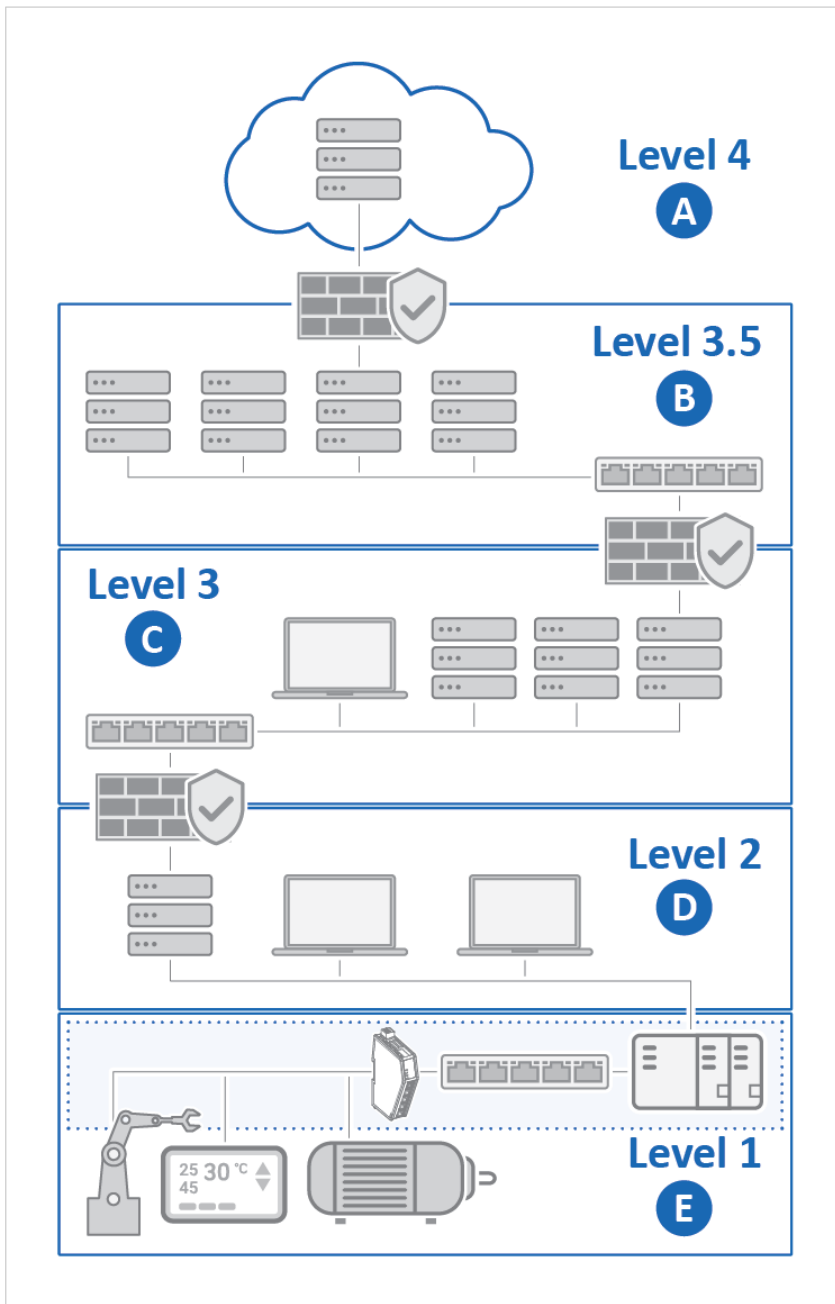

Figure 1. Purdue model, product security context

**IT Network**

- A. **Level 4: Enterprise Network**  
Example: Cloud solution, Business LAN (VPN)
- B. **Level 3.5: Perimeter Network**  
Example: Demilitarized Zone (DMZ)

**OT Network**

- C. **Level 3: Advanced Control Network (ACN)**  
Example: SCADA systems, Business control
- D. **Level 2: Supervisory Control**  
Example: Operator panels, Operator stations, Engineering stations
- E. **Level 1: Process Control Network (PCN)**  
**Environment where the Communicator is installed**  
Example: Factory floor, Industrial product line

## 4. Preparation

### 4.1. Cabling

Have the following cables available:

- Power cable.
- Ethernet cable for configuration.
- PROFIBUS cable for connecting to network.
- 7-pin screw terminal block connector is included with the product.

### 4.2. System Requirements

#### 4.2.1. Supported Operating Systems

Operating System	Description
Windows 7 SP1, 32-bit	Windows 7 32-bit with Service Pack 1
Windows 7 SP1, 64-bit	Windows 7 64-bit with Service Pack 1
Windows 10 64-bit	Windows 10 64-bit
Windows 11 64-bit	Windows 11 64-bit

#### 4.2.2. Supported Web Browsers

The Communicator built-in web interface can be accessed from the following standard web browsers.

- Google Chrome
- Microsoft Edge
- Mozilla Firefox

### 4.3. Mechanical Tools and Equipment

Have the following tools available:

- Flat-head screwdriver, size 5.5 mm  
Needed when removing the Communicator from DIN-rail.  
Needed when changing the position of the rotary switches.
- Flat-head screwdriver, size 3 mm  
Needed when connecting the cables to the 7-pin connector.

### 4.4. Support and Resources

For additional documentation and software downloads, FAQs, troubleshooting guides and technical support, please visit [www.anybus.com/support](http://www.anybus.com/support).



#### TIP

Have the product article number available, to search for the product specific support web page. You find the product article number on the product cover.

## 4.5. HMS Software Applications

Download the software installation files and user documentation from [www.anybus.com/support](http://www.anybus.com/support).

### HMS IPconfig

Use the software application HMS IPconfig and scan your network to discover and change the Communicator IP address and to access the Communicator built-in web interface.



#### NOTE

As an alternative, you can set a static IP address within the same IP address range as the Communicator IP address on the computer accessing the Communicator built-in web interface.



#### NOTE

HMS IPconfig is only available for Windows.

## 4.6. Third-Party Software Applications

### Microsoft Excel

Microsoft Excel, or equivalent software application that supports the Office Open XML Workbook (xlsx) file format. Needed to open and read the **I/O data map** file and the **Event log** file.

## 4.7. Software License Information

For license agreements regarding the third-party software used in the Communicator, refer to the *LICENSE.txt* file(s) included in the Communicator firmware update package zip file.

To download the Communicator firmware update package zip file, please visit [www.anybus.com/support](http://www.anybus.com/support).



#### TIP

Have the product article number available, to search for the product specific support web page. You find the product article number on the product cover.

## 5. About Anybus Communicator

### 5.1. Serial Protocol Communication

#### 5.1.1. Serial Protocol Types

The gateway features three distinct modes of operation for the subnetwork communication, called Modbus RTU, Custom Request/Response and Custom Produce/Consume.

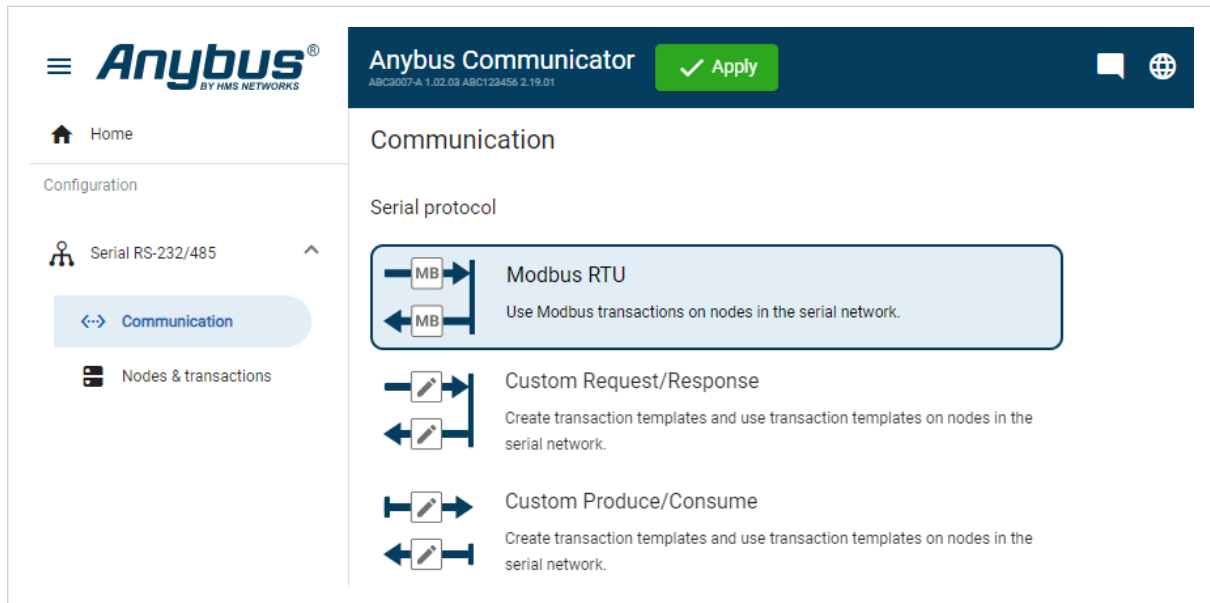

Figure 2. Communication, Serial protocol

#### Modbus RTU

By default the Communicator uses the Modbus RTU serial protocol.

The Communicator uses Modbus transactions defined by the Modbus standard.

The Communicator acts as a client on the subnetwork, and the serial communication takes place in a request/response fashion.

The nodes on the network are not permitted to issue messages unless they have been addressed by the Communicator first.

#### Custom Request/Response

In this mode, you can define your own serial transactions to handle a wide range of custom serial protocols.

The Communicator acts as a generic serial client on the subnetwork.

The serial communication takes place in a request/response fashion.

#### Custom Produce/Consume

In this mode, you can define your own serial transactions to handle a wide range of custom serial protocols.

The Communicator may consume and/or produce messages on the subnetwork.

There is no client-server relationship between the nodes on the network, messages are spontaneously produced or consumed when data is available.

### 5.1.2. Serial Protocol Building Blocks

The following building blocks are used to describe the subnetwork communication.

#### Node

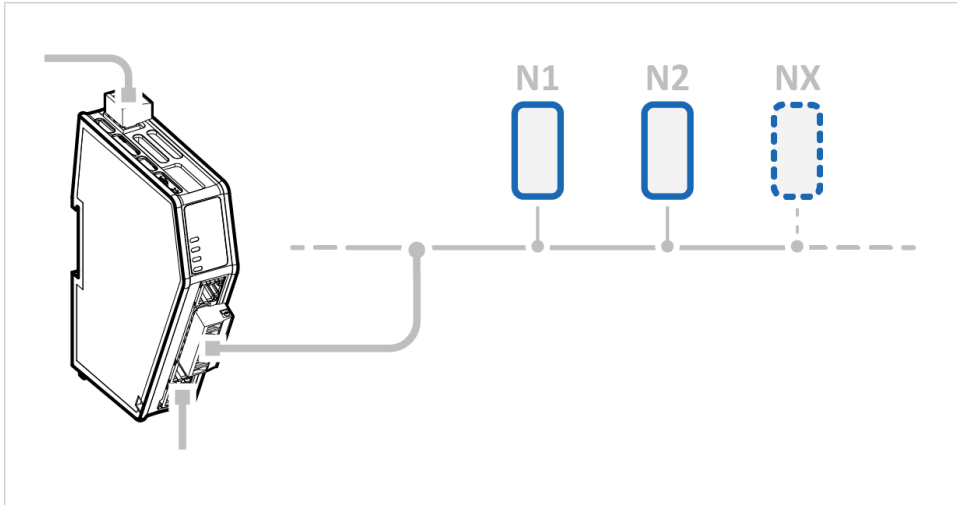

Figure 3. Nodes on a subnetwork

A node represents a single device on the subnetwork.

Each node can be associated with a number of transactions.

#### Nodes and Transactions

Active	Transaction name	Transaction template name	Size to EtherNet/IP™ (bytes)	Size from EtherNet/IP™ (bytes)
<input checked="" type="checkbox"/>	Control Word	Write Parameter (0x02)	0	2
<input type="checkbox"/>	Speed	Write Parameter (0x02)	0	2
<input type="checkbox"/>	Status Word	Read Parameter (0x01)	2	0
<input type="checkbox"/>	Actual Speed	Read Parameter (0x01)	2	0

Figure 4. Node with Transactions

Transactions are based on standard Modbus RTU transactions (Modbus RTU serial protocol) or transactions templates (Custom Request/Response or Produce/Consume serial protocol) and define the data to be sent or received.

Each transaction has a number of parameters that need to be configured to define how data is to be sent / received.

## Frame Fields

The Frame editor is used to design custom transaction templates.

The Frame editor with Frame fields is available when either the Custom Request/Response or Custom Produce/Consume serial protocol is enabled.

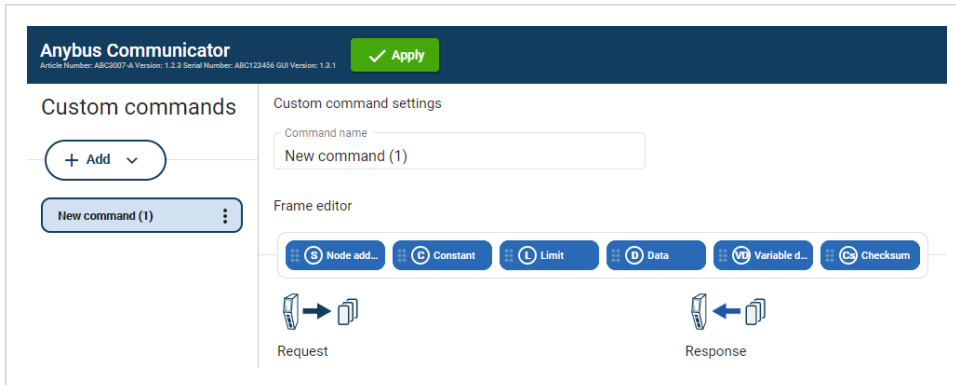

Figure 5. Frame editor

Frame fields are low level entities used to compose transactions.

A frame object can represent a:

- fixed value, a constant
- range of values, limit objects
- block of data or a calculated checksum

## Transaction Templates

The Transaction templates are available when either the Custom Request/Response or Custom Produce/Consume serial protocol is enabled.

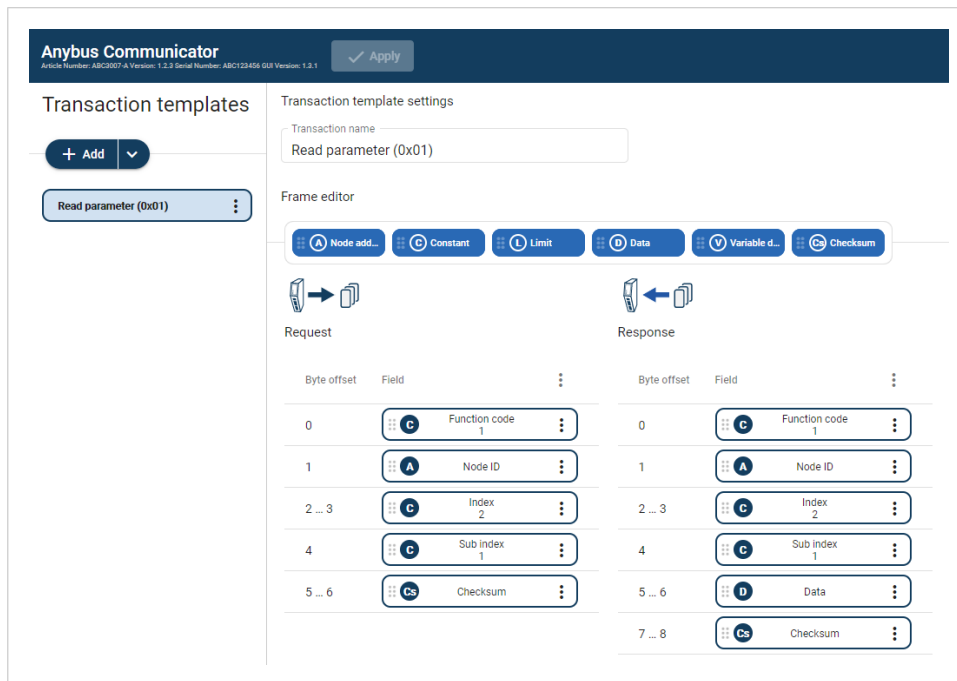

Figure 6. Frame editor, Request and Response

A transaction represents a complete serial telegram, and consists of a number of frame fields.

Each frame field is associated with a set of parameters controlling what is transmitted on the subnetwork.

The transaction templates are stored in the Communicator and can be reused multiple times.

### Example 1. Common Read Transaction

If you have a common read transaction. Then you can create one single transaction template for the read transaction and reuse it multiple times on your node(s).

If you have a function code in your protocol similar to a standard Modbus RTU transaction. Then you can create a transaction template based on the Modbus RTU transaction for the read operation. When you reuse the template on your node(s), you only have to change the function code each time it is used.

## 5.2. How the Communication Works

The Communicator enables communication, data exchange, between one or more server devices connected to a serial subnetwork and a client device connected to a high level network.

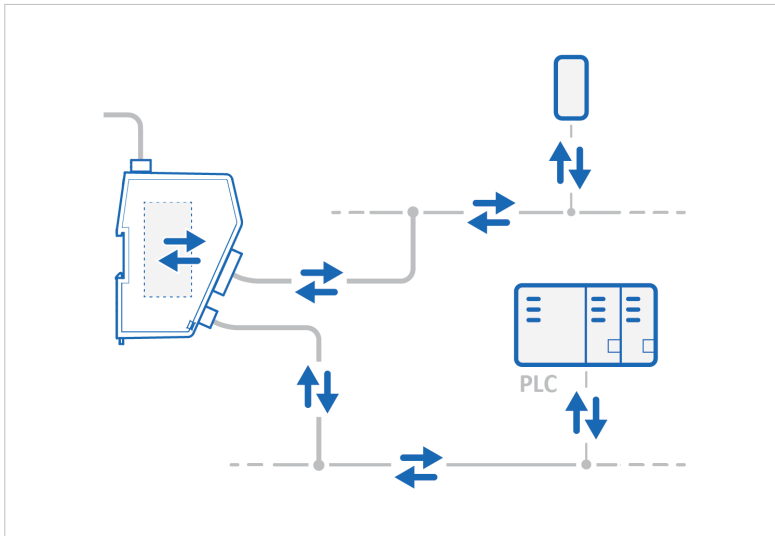

Figure 7. Process data traffic overview

For example:

- The client device can be a PLC controller or a PC.
- A server device can be a sensor, scanner, industrial robot, or sniffer.

The Communicator main task is to send the transactions that the server device(s) are configured to execute, in order to request and transfer process data.

### Request Process Data

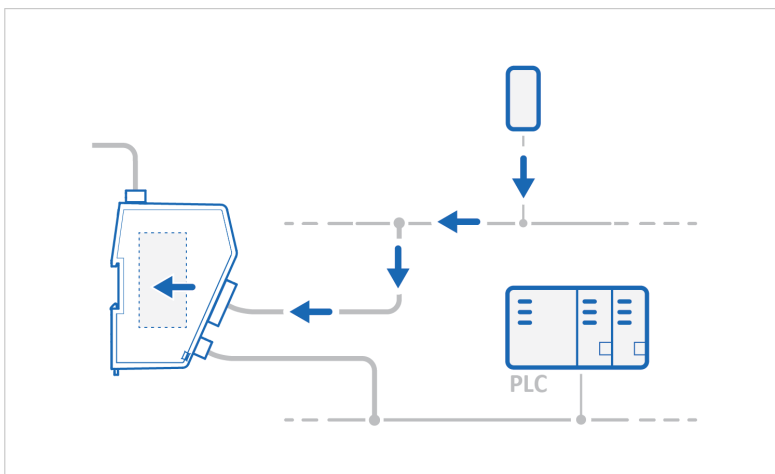

Figure 8. Process data traffic from nodes to client

Request process data from the serial subnetwork nodes, specified in the Communicator configuration, and make the process data available on the server interface and for the high level network client device.

### Transfer Process Data

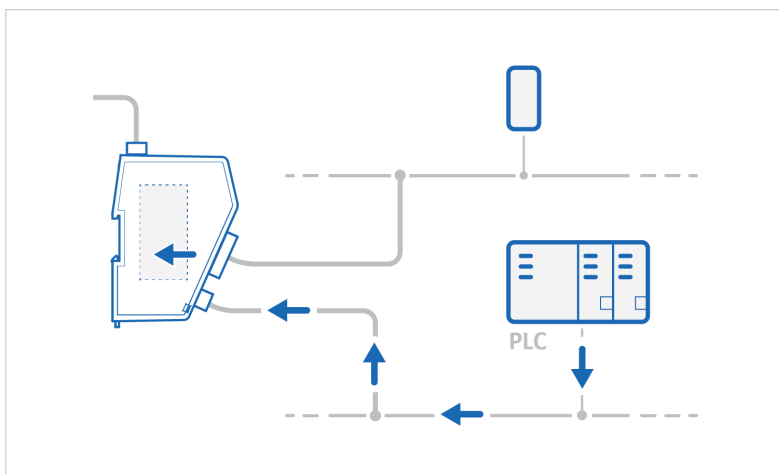

Figure 9. Process data traffic from client to nodes

Transfer process data from the high level network client device and make it available on the server interface and for the serial subnetwork nodes included in the configuration.

### 5.3. How the Data Exchange Works

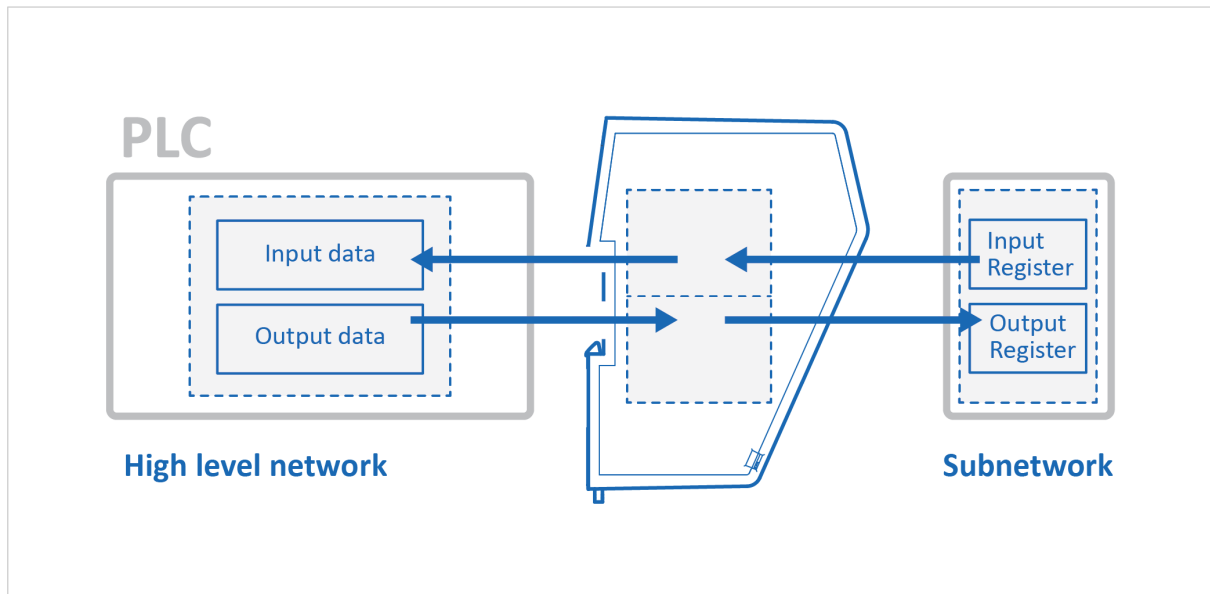

Figure 10. The Communicator internal memory areas

The data exchanged between the Communicator and the serial subnetwork and the high level network resides in the Communicator internal memory buffer.

To exchange data with the serial subnetwork, the high level network reads and writes data to the Communicator internal memory buffer.

The same memory locations are exchanged on the serial subnetwork.

The memory locations are specified when configuring the Communicator using the Communicator built-in web interface.

#### Input Data

The Input data area is read by the high level network.

#### Output Data

The Output data area is read/written by the high level network.

### 5.4. Data Integrity

A snapshot of the process data buffer between the Client and the server interface is used during the operation of executing all the transactions within one cycle.

When the cycle is completed, the process data available on the server interface is updated and a new snapshot is created for the next cycle.

## 6. Installation

### 6.1. External Parts

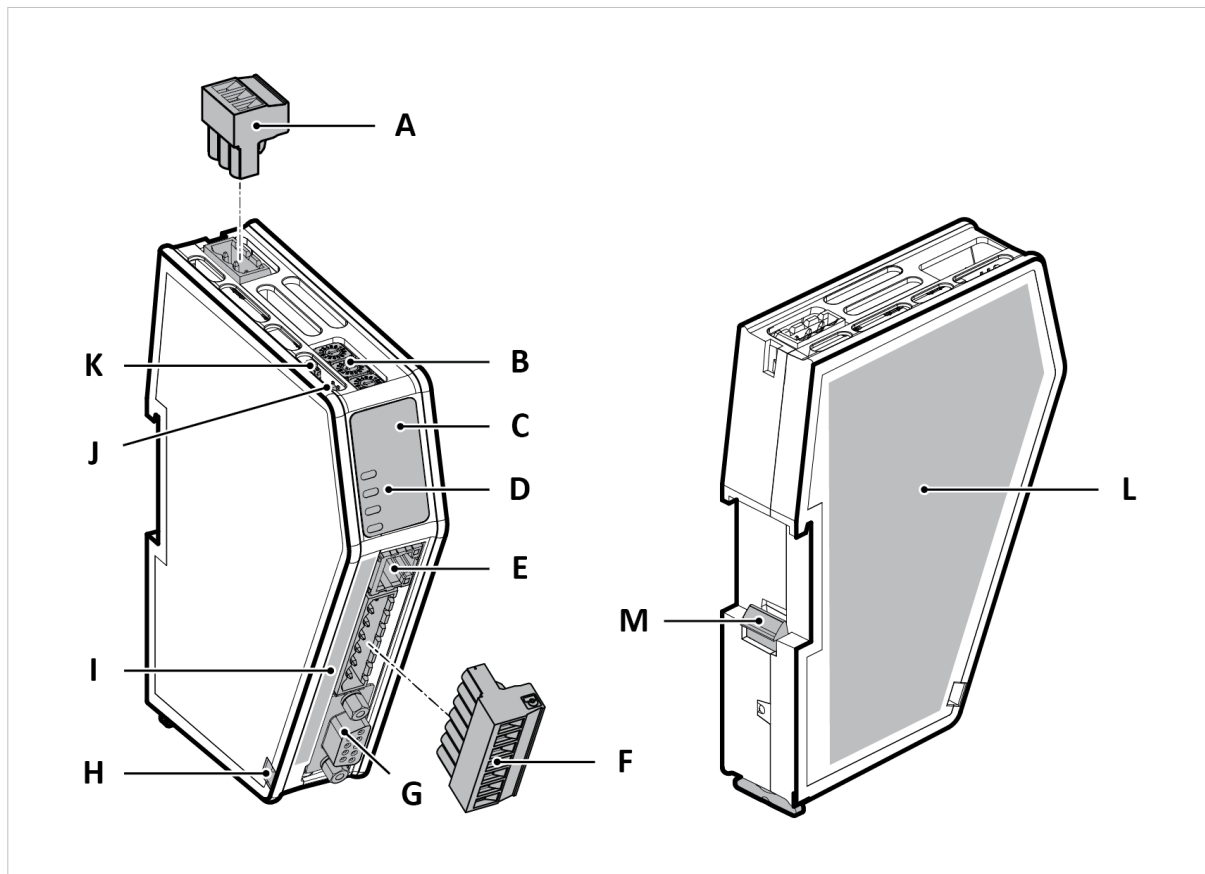

Figure 11. External parts

- |  |  |  |
|--|--|--|
| A. Power connector                           | F. 7-pin connector                       | J. Security switch                               |
| B. Rotary Switch x 3<br>For PROFIBUS address | G. PROFIBUS DSUB connector               | K. Factory reset button                          |
| C. Label with LED designation                | H. Cable tie mount                       | L. Laser engraved label with product information |
| D. Status LEDs                               | I. Laser engraved connectors designation | M. DIN rail locking mechanism                    |
| E. Configuration port                        |  |  |

## 6.2. Connector Port Guide

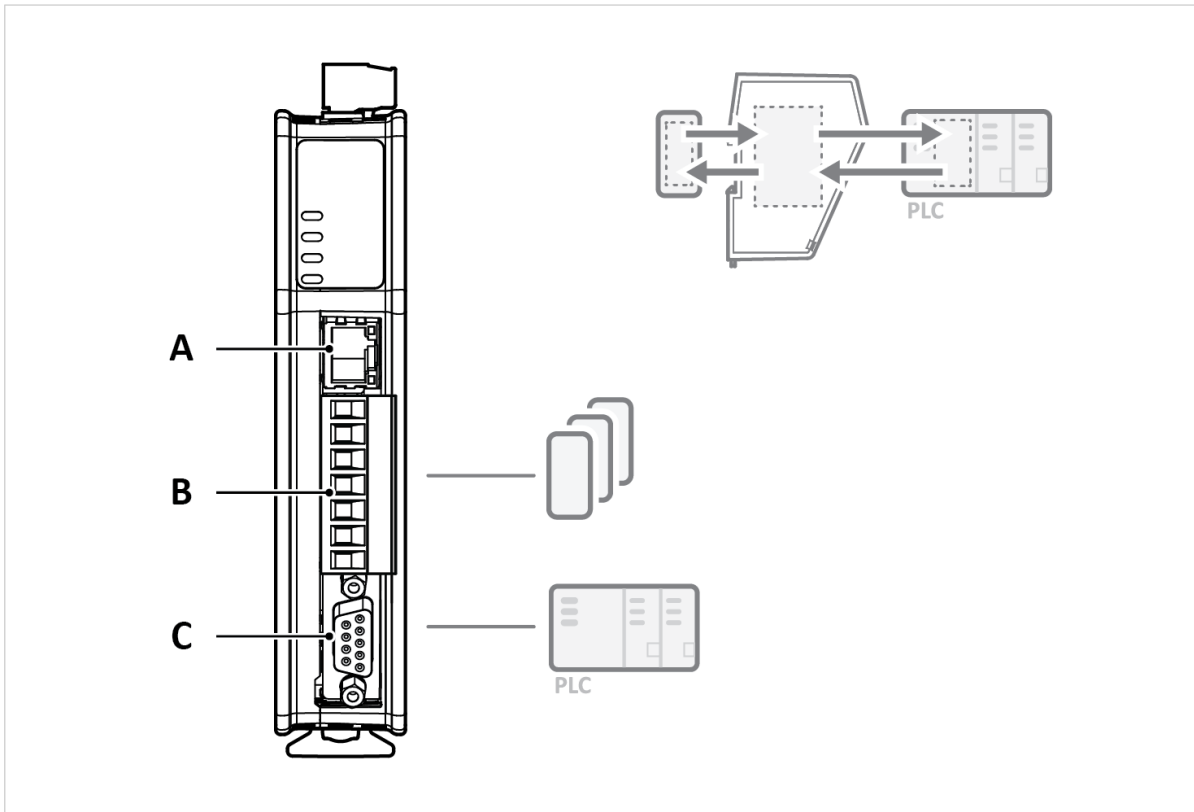

Figure 12. Communicator connector ports

Position	Port Number	Connector Type	Port Usage
A	X1	Ethernet	Configuration port
B	X2	Serial	Serial RS-232/485 Device
C	X3	D-SUB	PROFIBUS network

See also [Connect to PROFIBUS Network \(page 19\)](#) and [Connect to Serial RS232/RS485 Subnetwork \(page 20\)](#).

## 6.3. DIN Rail Mounting



### IMPORTANT

The equipment must be electrically grounded through the DIN rail for EMC compliance. Make sure that the equipment is correctly mounted on the rail and that the rail is properly grounded.



### IMPORTANT

To physically secure networks and equipment and to prevent unauthorized access, it is recommended to install the equipment in a locked environment.

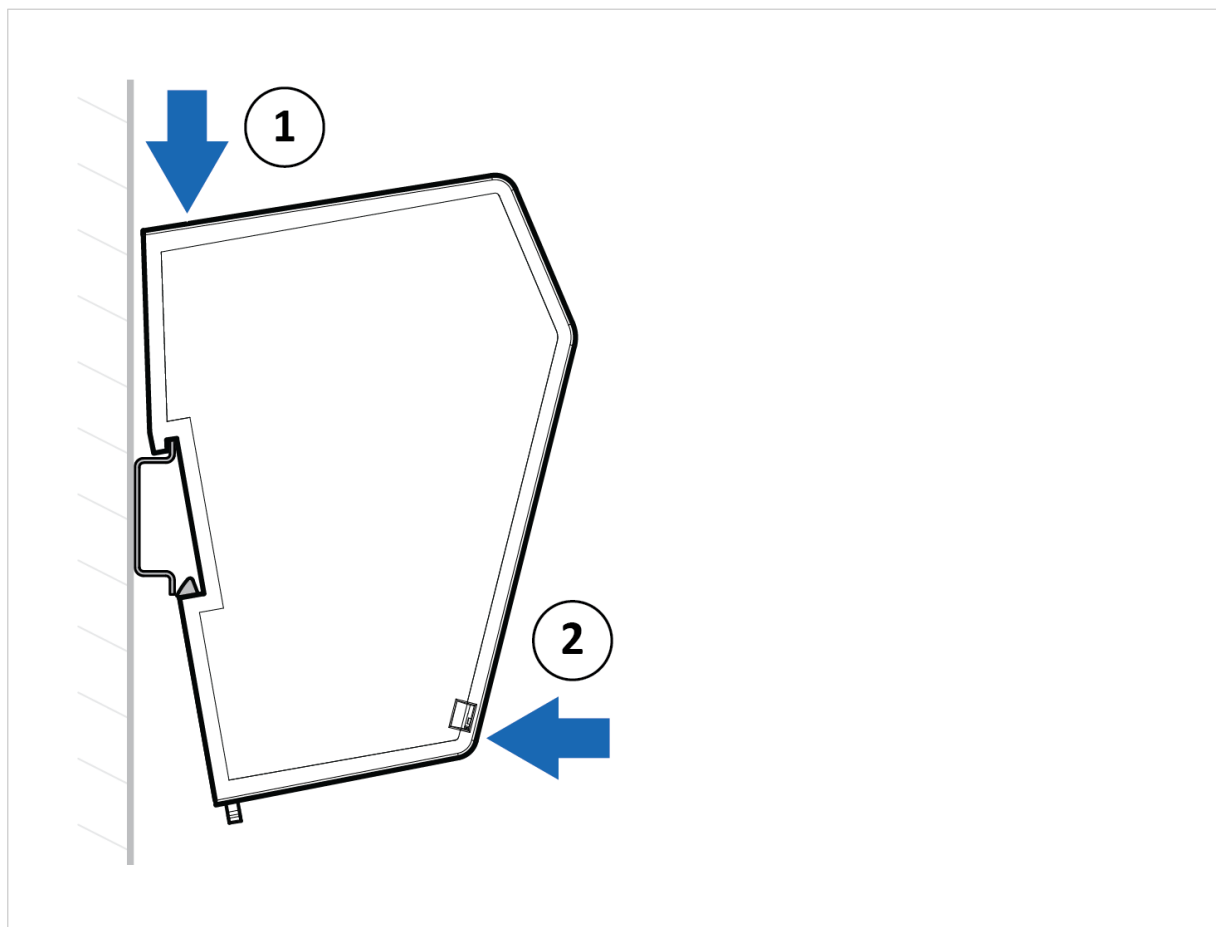

Figure 13. Attach the Communicator on the DIN rail

To attach the Communicator on the DIN rail:

1. Insert the upper end of the DIN rail clip into the DIN rail.
2. Push the bottom of the DIN rail clip into the DIN rail.

## 6.4. Connect to PROFIBUS Network

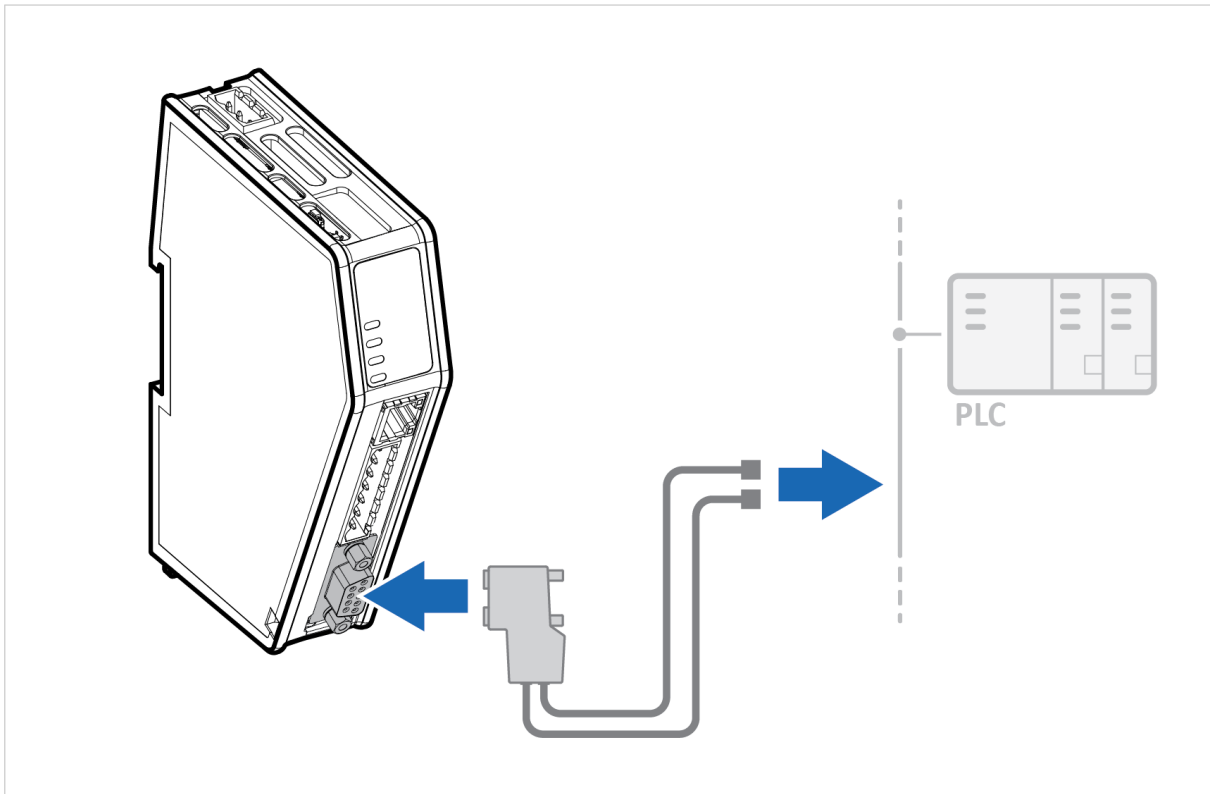

Figure 14. Connect to PROFIBUS network

1. Connect the Communicator to your PROFIBUS network.

PROFIBUS Connector	Pin	Description
	1	Not used
	2	Not used
	3	Line B
	4	RTS
	5	GND Bus
	6	+5 V Bus Out
	7	Not used
	8	Line A
	9	Not used
	Housing	PE

### To Do Next

Connect the Communicator to the Serial RS-232/485 network, set the node address on the rotary switches and connect to power.

Check LED status, refer to [Communicator LED Indicators \(page 121\)](#).

## 6.5. Connect to Serial RS232/RS485 Subnetwork

**NOTE**

Use minimum 90 oC copper (Cu) wire only.

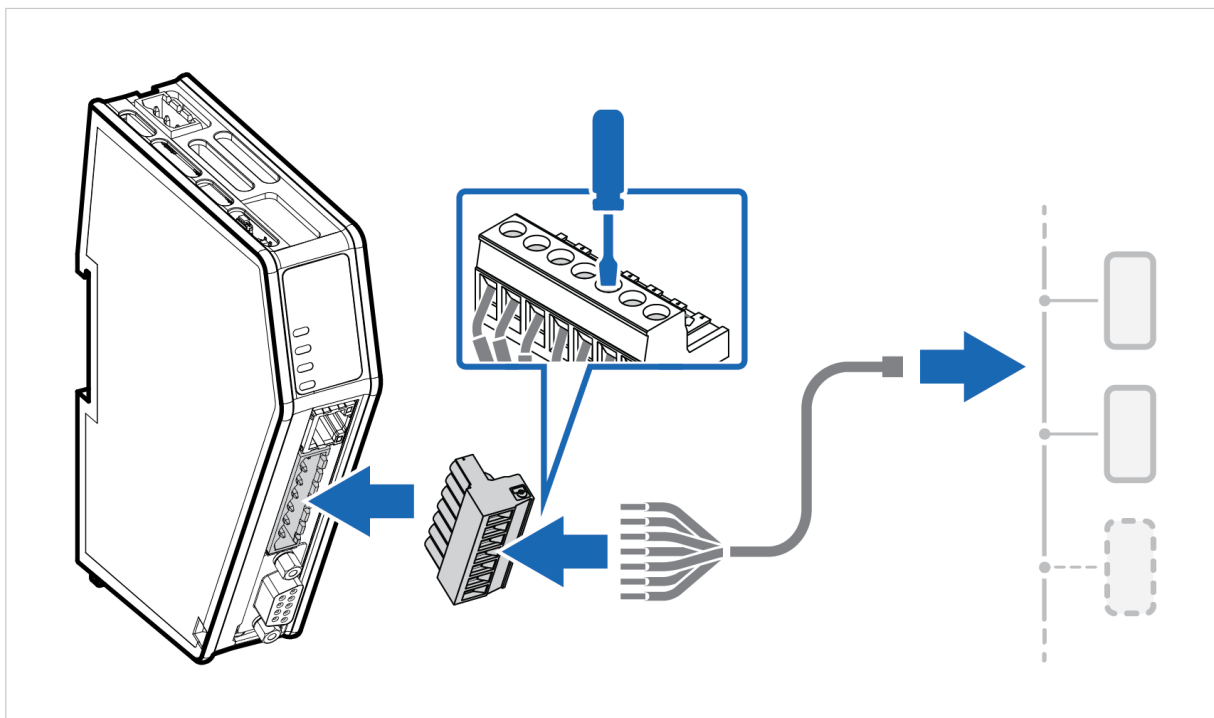
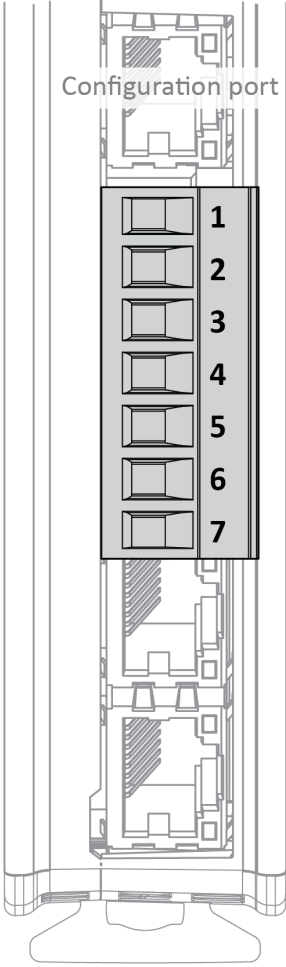

Figure 15. Connect to serial RS232/RS485 subnetwork

1. Insert the cable wires into the 7-pin connector and tighten the wire clamp screws.

7-pin connector	Pin	Signal
	1	+5 V OUT
	2	RS485+ A
	3	RS485- B
	4	Signal GND
	5	Functional Earth (FE)
	6	RS232 Tx Transmit Data
	7	RS232 Rx Receive Data

2. Connect the 7-pin connector to the Communicator.
3. Connect the Communicator to your serial subnetwork.

### To Do Next

Connect the Communicator to the PROFIBUS network, set the node address on the rotary switches and connect to power.

Check LED status, refer to [Communicator LED Indicators \(page 121\)](#).

## 6.6. Rotary Switch Settings

### 6.6.1. Rotary Switches Default Setting

By default, the value on the three rotary switches are set to **000**.

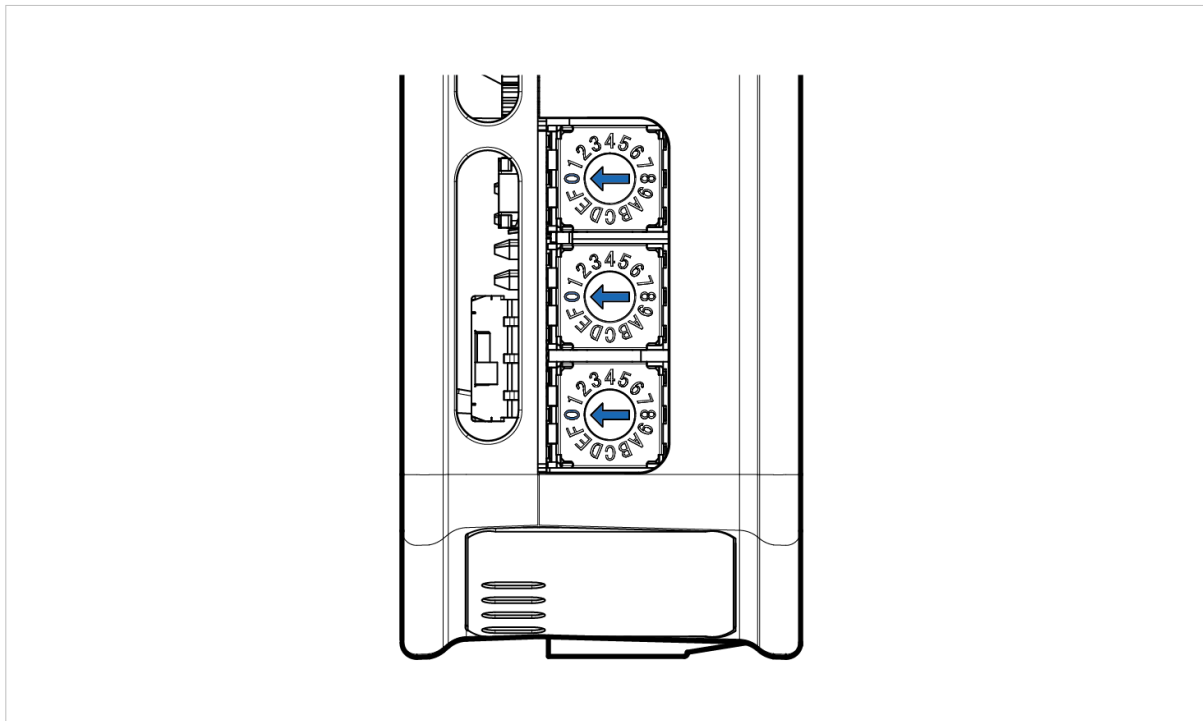

Figure 16. Rotary switches default setting **000**.

## 6.6.2. Set a Node Address with Rotary Switches

### About the Rotary Switch Settings

To set a node address for the PROFIBUS server, use the rotary switches located on the top front of the Communicator .



#### TIP

Use Windows Calculator (or similar application) to convert between hexadecimal (hex) and decimal (dec).

- The default node address setting is 000.
- When the node address setting is 000, you can set the node address via the Communicator built-in web interface.  
See [PROFIBUS Address Settings \(page 95\)](#).
- The node address values are set in hexadecimal (hex).
- Minimum value is 00.
- Supports PROFIBUS node addresses 0-126 Dec (0-7E Hex).
- Each node address may only occur once in the network.
- The node address is read from the center rotary switch x16 to the front rotary switch x1.
- The rear rotary switch is not used, ensure that it is set to 0.

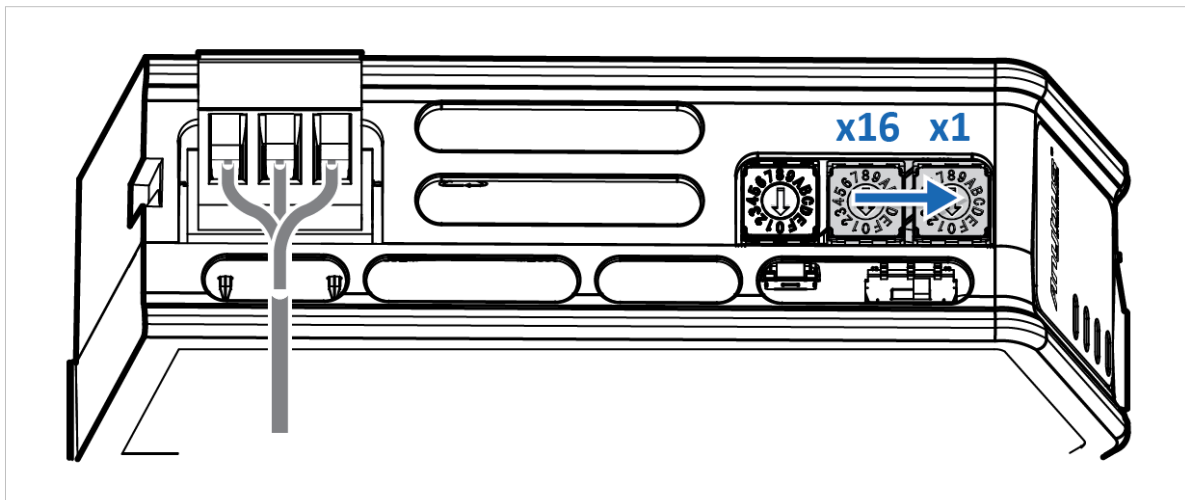

**Before You Begin**

Ensure that the Communicator is disconnected from power.

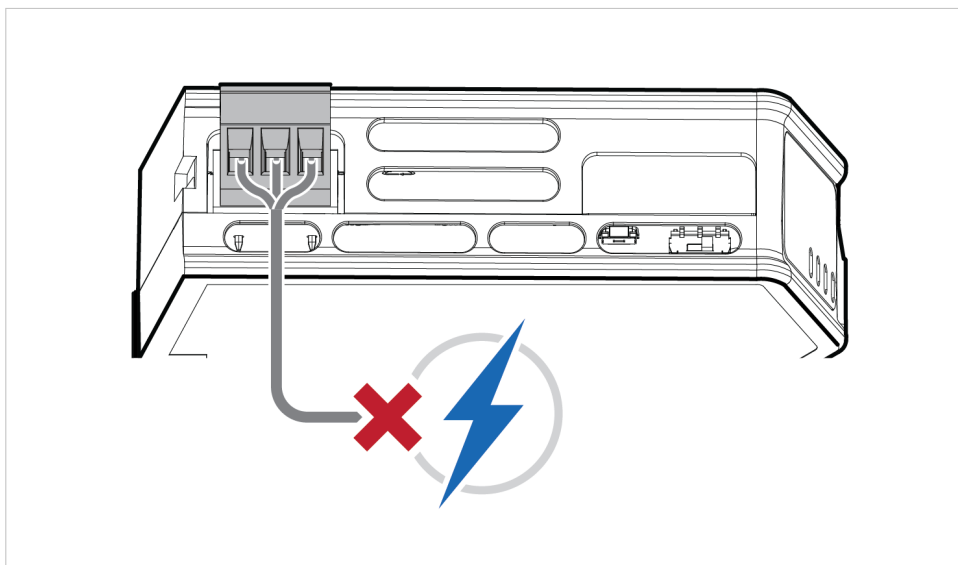
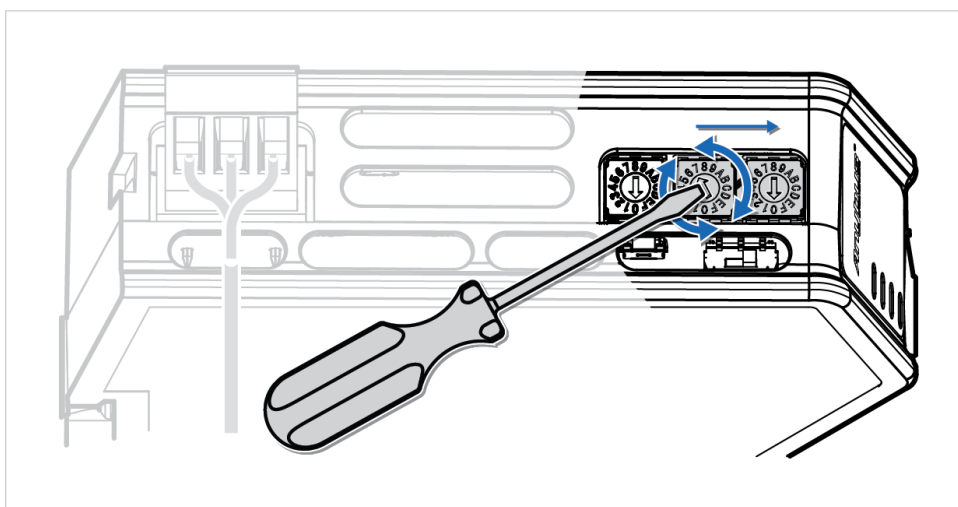

Figure 17. Disconnect Communicator from power

**Procedure**

Use a screwdriver to change the rotary switch position.

Ensure that the rotary switches engage correctly.



Example 2. To set the node address 12 hex = 18 dec

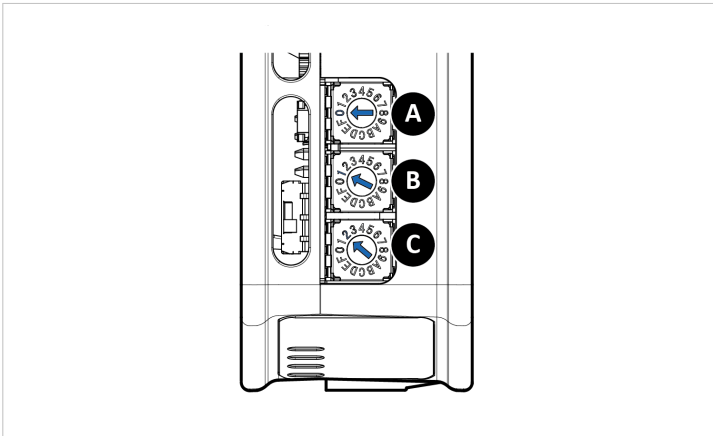

1. The rear rotary switch A is not used, ensure that it is set to 0.
2. Set the center rotary switch B to 1 hex.
3. Set the front rotary switch C to 2 hex.

The center rotary switch B 1 hex = 1 dec and the front rotary switch C 2 hex = 2 dec.

The node address expressed in decimal numbers is therefore  $16 \times 1 + 2 = 18$ .

Example 3. To set the node address 7E hex = 126 dec

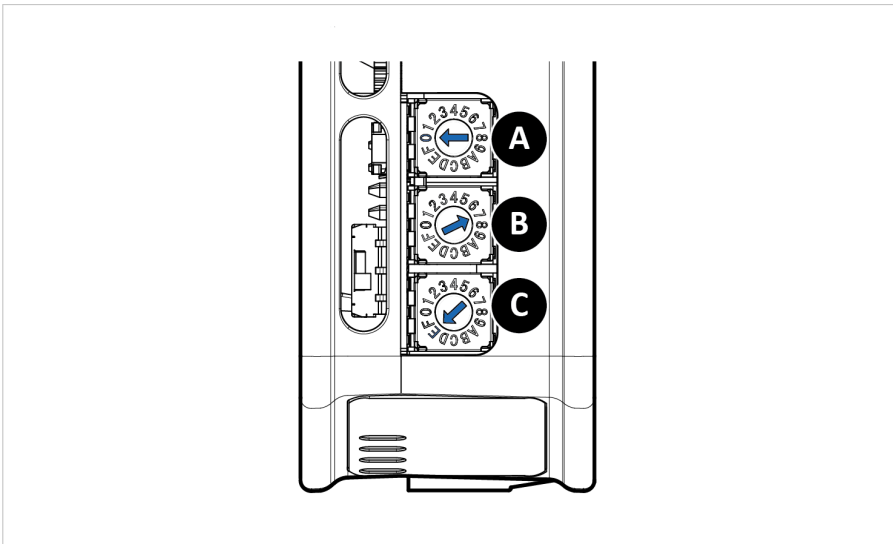

- The rear rotary switch A is not used, ensure that it is set to 0.
- Set the center rotary switch B to 7.
- Set the front rotary switch C to E.

The center rotary switch B 7 hex = 7 dec and the front rotary switch C E hex = 14 dec.

The node address expressed in decimal numbers is therefore  $16 \times 7 + 14 = 126$ .

**To Do Next**

Connect the Communicator to power. See [Connect to Power \(page 27\)](#).

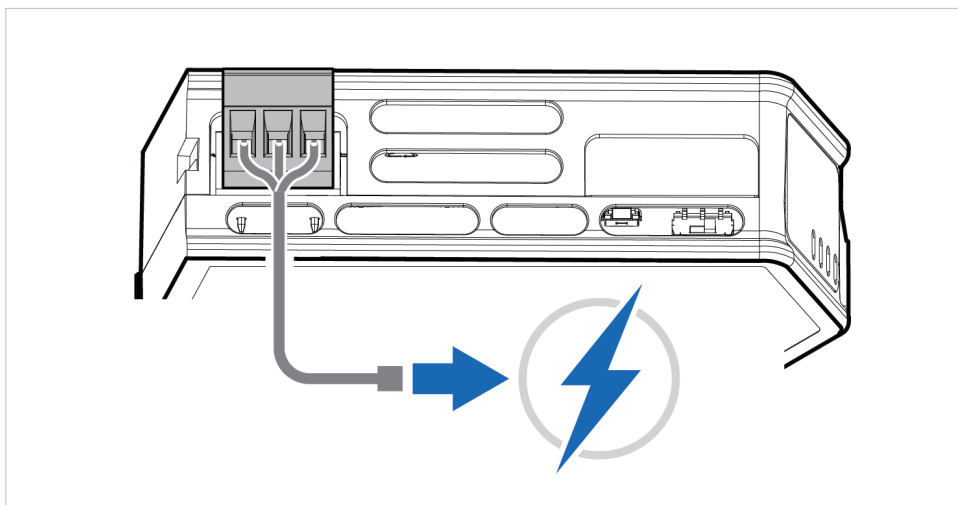

Figure 18. Connect Communicator to power

**Result**

The set node address is active as soon as the Communicator is powered on.



**NOTE**

Changing the address settings on the rotary switches during operation is ignored. For a new address to take effect, power cycle the Communicator.

## 6.7. Connect to Power



### CAUTION

Ensure that the power supply is turned off before connecting it to the equipment.



### IMPORTANT

Using the wrong type of power supply can damage the equipment. Ensure that the power supply is connected properly and of the recommended type.



### IMPORTANT

Before you connect the Communicator to power, ensure that the PROFIBUS address is set on the rotary switches. If the PROFIBUS address is set when the Communicator is operating, you must power cycle the Communicator for the new setting to take effect.

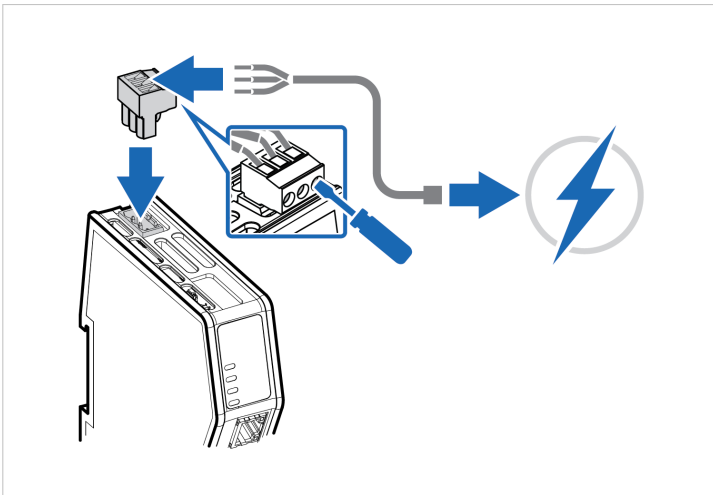

Figure 19. Connect to power

### Power Connector Pinout

Power port	Pin	Description
	1	12-30 VDC Power Connector
	2	Ground (GND)
	3	Functional Earth (FE)

### Procedure

1. Insert the cable wires to the terminal block and tighten the wire clamp screws.
2. Connect the terminal block to the Communicator.
3. Connect the Communicator to a power supply.
4. Turn on the power supply.

## 6.8. Security Switch



### IMPORTANT

After completing the configuration of the Communicator, lock the security switch to prevent unauthorized access to the Communicator built-in web interface.

When the security switch is in its locked position, the Communicator built-in web interface cannot be accessed, and the Communicator cannot be configured using the built-in web interface. Network specific parameters, configured via the PLC is still available.

### To Lock and Unlock the Security Switch

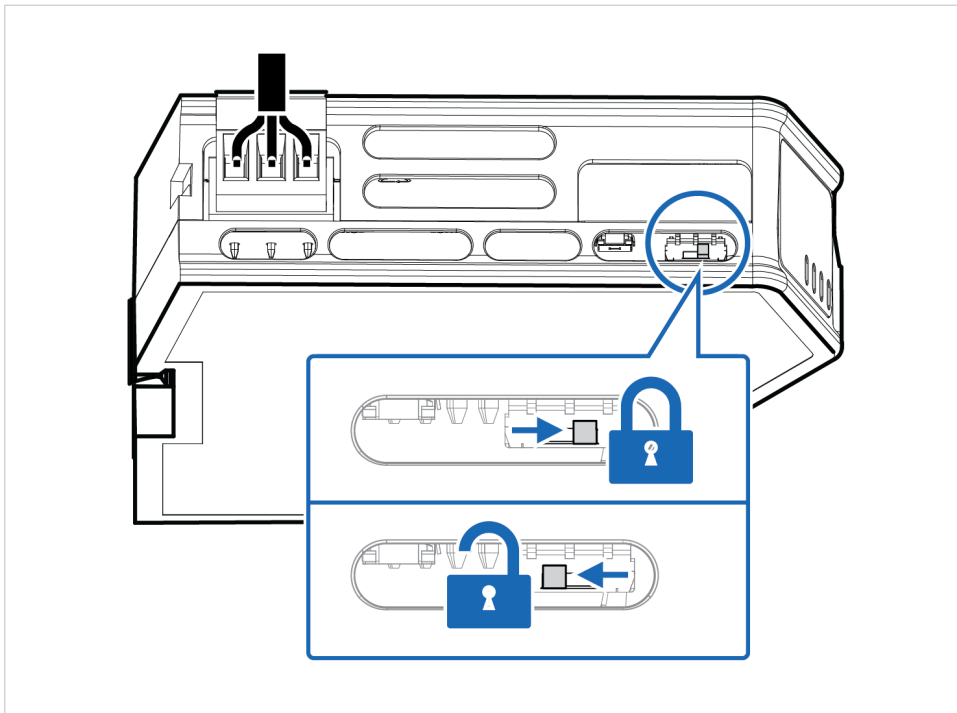

Figure 20. Security switch in locked and unlocked position

Use a pointed object, such as a ballpoint pen.

- To **lock** the security switch, push the toggle towards the **Communicator front**.
- To **unlock** the security switch, push the toggle towards the **Communicator back**.

## Security Switch Status LED

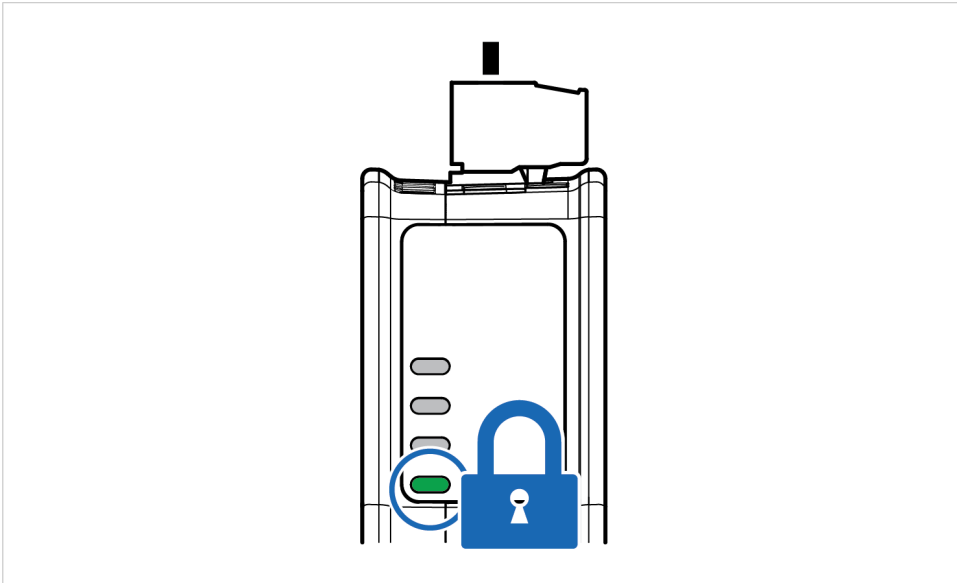

Figure 21. Security switch locked status LED

When the security switch is in its:

- locked position, the security switch status LED turn solid green.
- unlocked position, the security switch status LED is turned off.

## 6.9. Lock the Cables

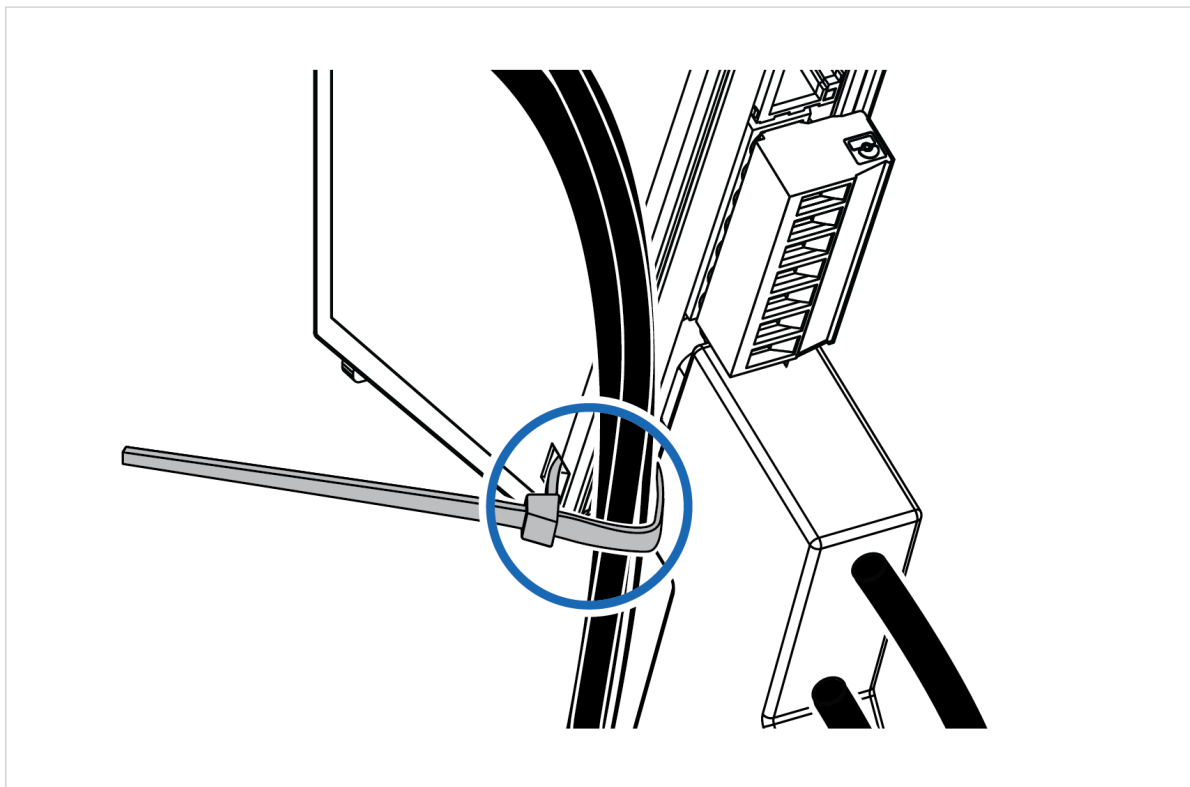

Figure 22. Lock the cables

To strain relieve the cables, place a cable tie in the holder and lock the cables.

## 6.10. DIN Rail Demount

### Before You Begin



#### IMPORTANT

Be careful when removing the Communicator from the DIN-rail. If not removed properly, the DIN rail locking mechanism and the product cover can break.

Have a flat-blade screwdriver, size 5.5 mm, available.

### Procedure

Remove the Communicator from the DIN rail:

1. Insert the screwdriver into the Communicator DIN rail locking mechanism.
2. To unlock the Communicator DIN rail locking mechanism, turn the screwdriver clockwise.

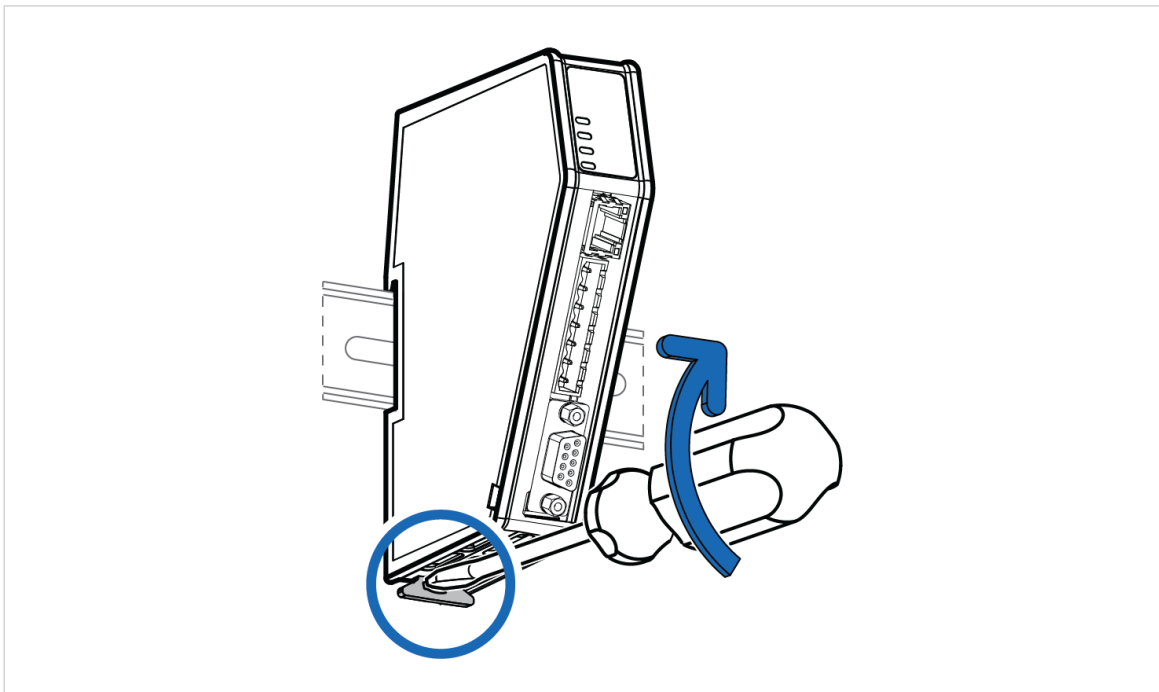

Figure 23. Unlock the Communicator

3. Hold the screwdriver in the DIN rail locking mechanism while you unhook the Communicator from the DIN rail.

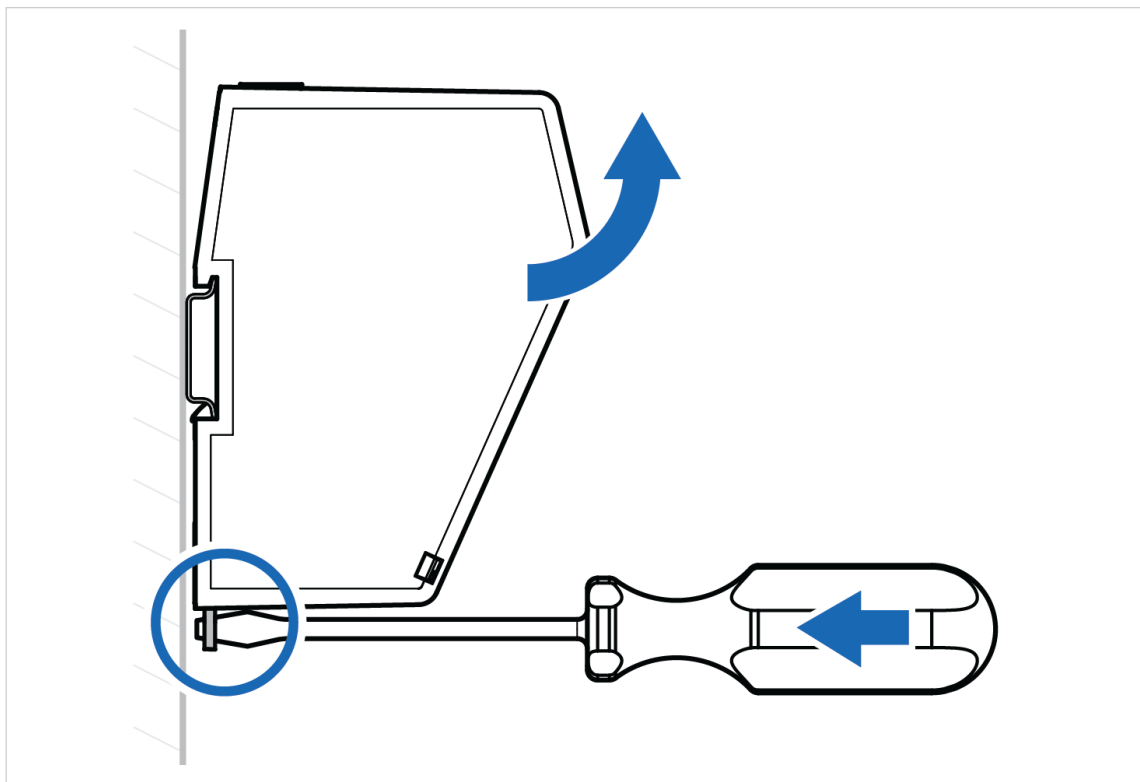

Figure 24. Unhook the Communicator

## 7. Configuration Quick Guide

This section is intended to give you a brief overview of the tasks you need to perform to configure the Communicator.

For detailed information, please refer to [Communicator Configuration \(page 43\)](#).

### 7.1. Prepare Configuration

1. **Connect Communicator to the PROFIBUS network.**

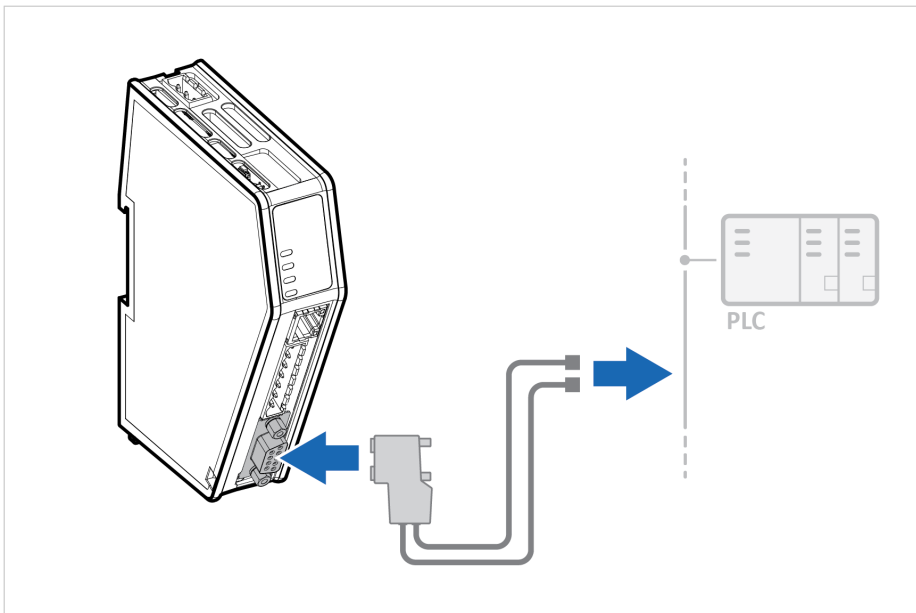

2. **Connect the Communicator to the serial RS232/RS485 subnetwork**

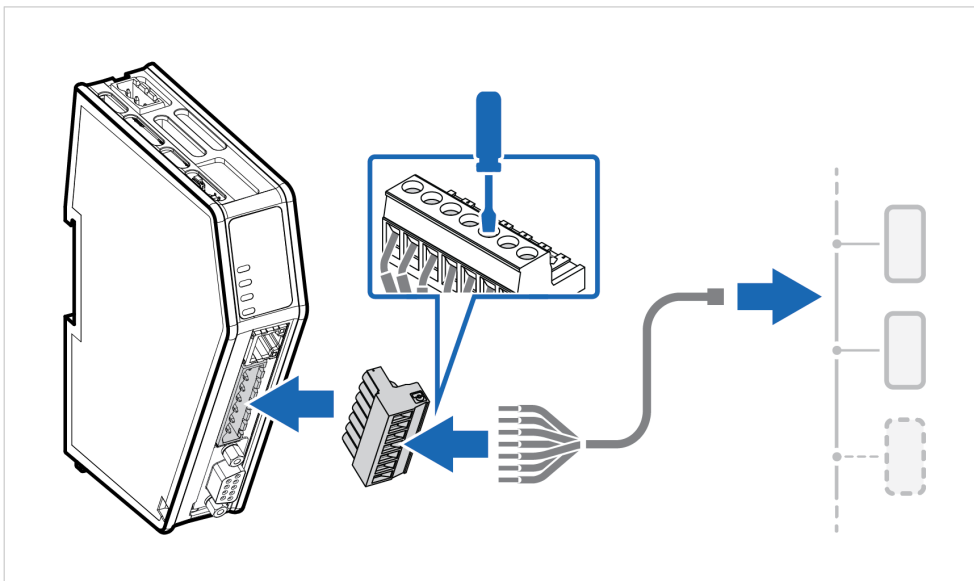

3. Set the desired PROFIBUS address on the Rotary Switches.

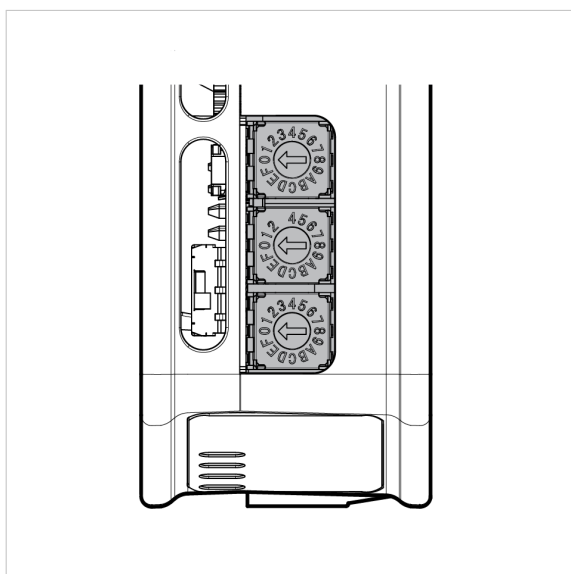

The default setting is 0.

For more info see [Rotary Switch Settings \(page 22\)](#).

4. Connect to PC and power

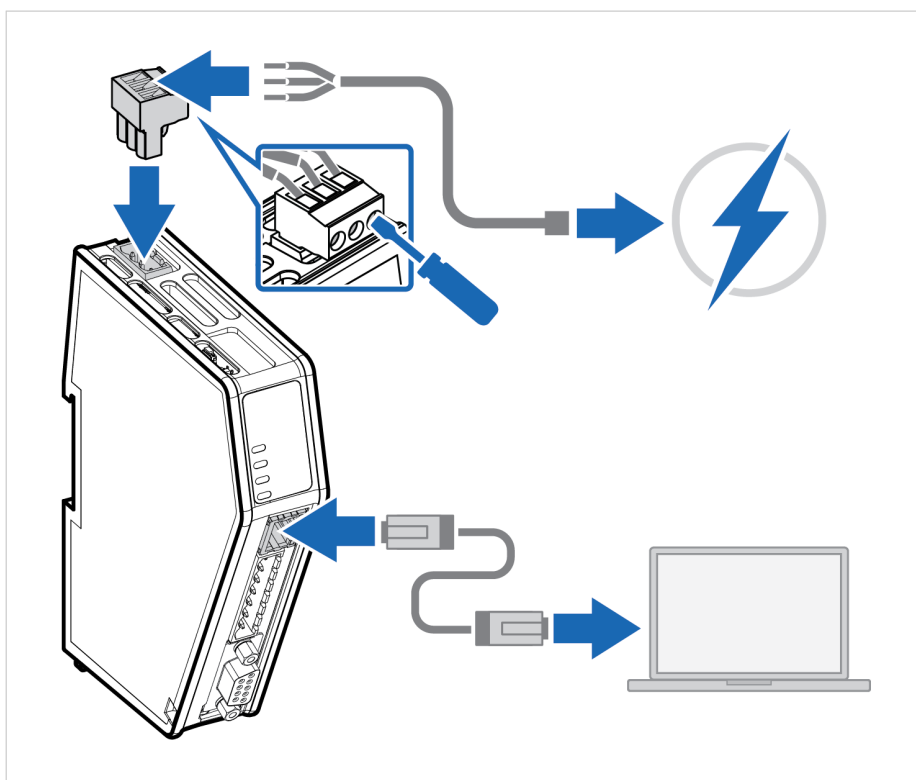

- a. Connect an Ethernet cable between the Communicator configuration port and your PC.
- b. Connect the Communicator to a power supply.

5. Find the Communicator on your PC

The Communicator default IP address is 192.168.0.10.

Option 1	Option 2
<div data-bbox="296 394 662 676" data-label="Image"> </div> <p data-bbox="245 741 754 813">On the PC accessing the Communicator built-in web interface, set a static IP address within the same IP address range as the Communicator IP address.</p>	<div data-bbox="959 394 1171 752" data-label="Image"> </div> <p data-bbox="834 808 1377 860">Change the IP address on the Communicator configuration port to one within the same IP address range as your PC.</p> <p data-bbox="834 871 1276 920">Use the software application HMS IPconfig to find the Communicator default IP address on your PC.</p> <p data-bbox="834 931 1334 981">Download the installation files and user documentation from <a href="http://www.anybus.com/support">www.anybus.com/support</a>.</p>

6. Access the Communicator built-in web interface

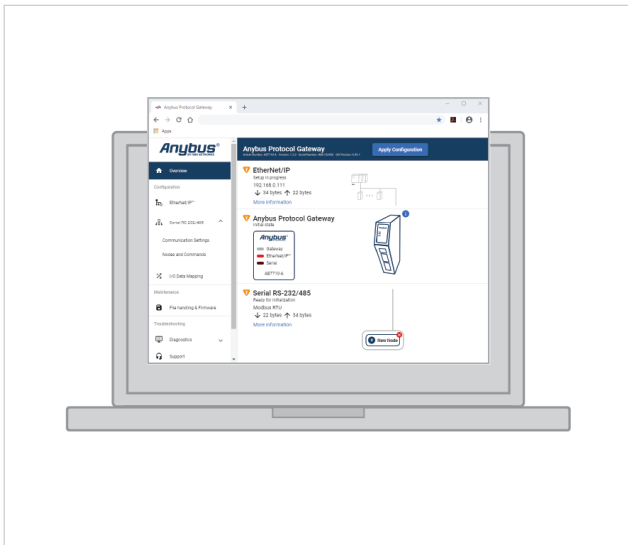

Open the Communicator built-in web interface in HMS IPconfig or enter the Communicator IP address in your web browser.

The Communicator built-in web interface overview page opens in your browser.

## 7.2. Setup New Configuration

Follow these steps to setup a new Communicator configuration.

### 1. Subnetwork configuration

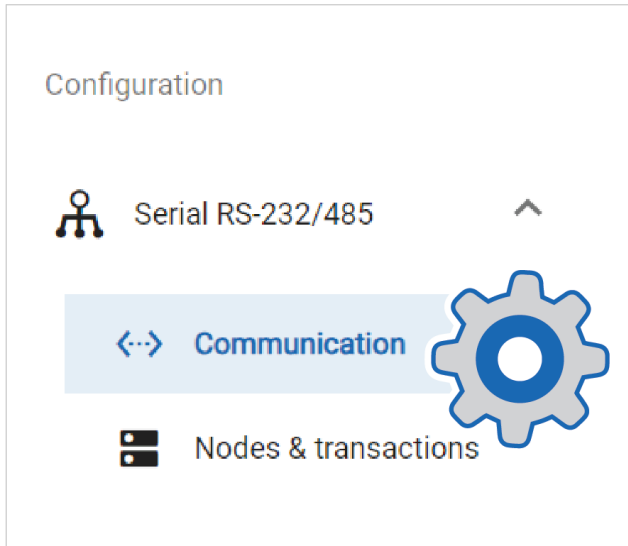

On the **Communication** page:

- a. Select a serial protocol: **Modbus RTU** (default), **Custom Request/Response** or **Custom Produce/Consume**.  
For information about the serial protocol types, see [Serial Protocol Types \(page 9\)](#).
- b. Configure the basic settings Physical standard:, Baud rate, Data bits, Parity and Stop bits.

### 2. Create Transaction Templates

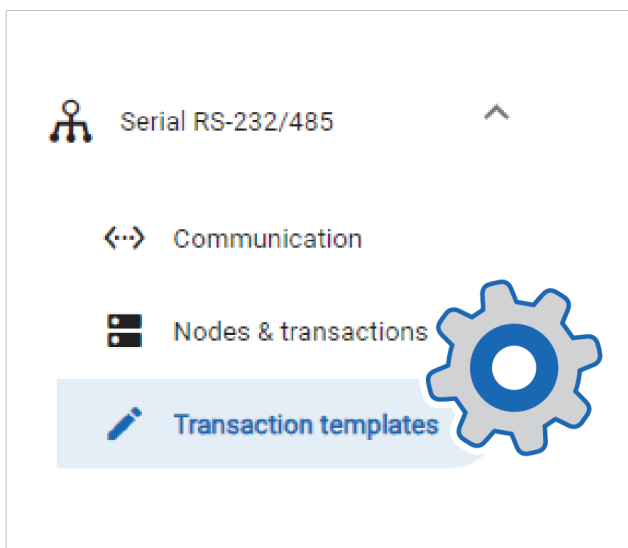

This step applies when the serial protocol **Custom request/response** is selected.

On the **Transaction templates** page: Add a transaction template and configure the template settings.

Repeat until you have added and configured all your transaction templates.

### 3. Add Nodes and Transactions

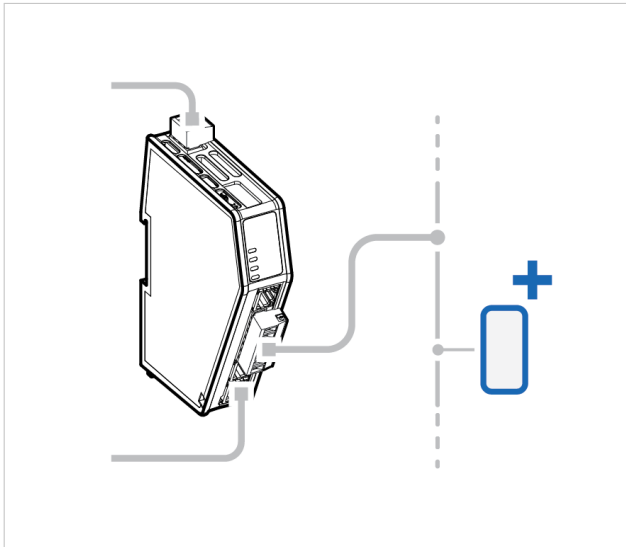

On the **Nodes & transactions** page:

- a. Add a node and configure the node settings.
- b. Add commands to the node and configure the command settings.
- c. Repeat until you have added and configured all your nodes.

### 4. High level network configuration

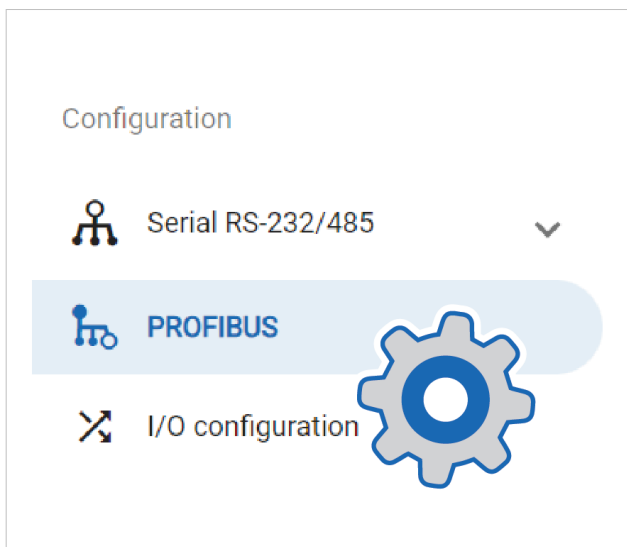

On the **PROFIBUS** page:

1. Use Automatic I/O sizes provided by the subnetwork or choose to set them manually.
2. If the rotary switches are set to 0, set the PROFIBUS address.

### 5. I/O Data Mapping

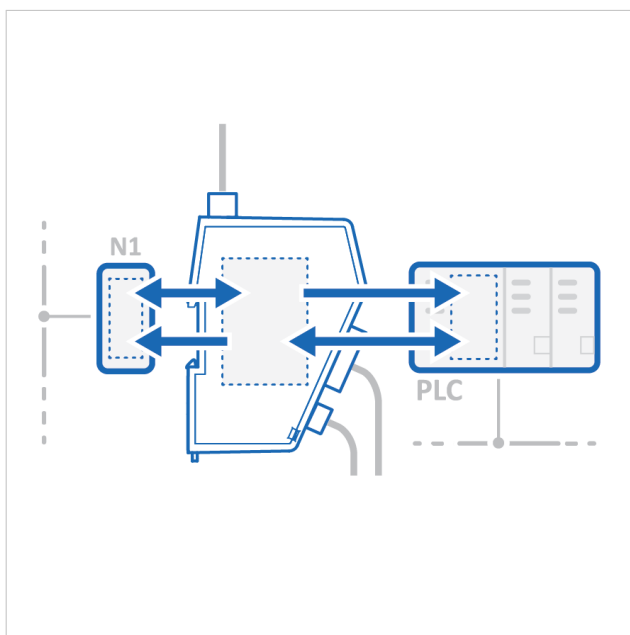

The commands you added to the nodes are automatically mapped to the Communicator internal memory area.

View the added nodes and commands on the **I/O configuration** page.

## 7.3. PLC Configuration

In the Communicator built-in web interface:

### 1. Export I/O data map

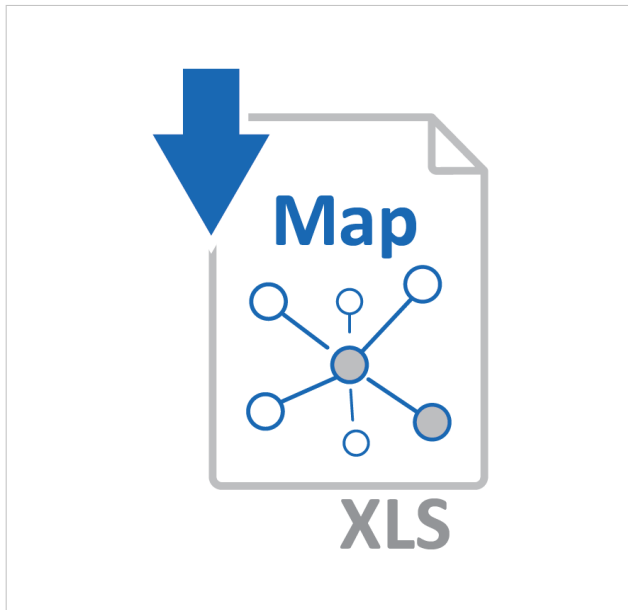

When you configure the communication between the Communicator and the PLC, you can use the I/O data map as a specification to ensure that the commands match.

On the **I/O configuration** page: You can download the I/O data mapping in a spreadsheet to your PC.

### 2. Download GSD File

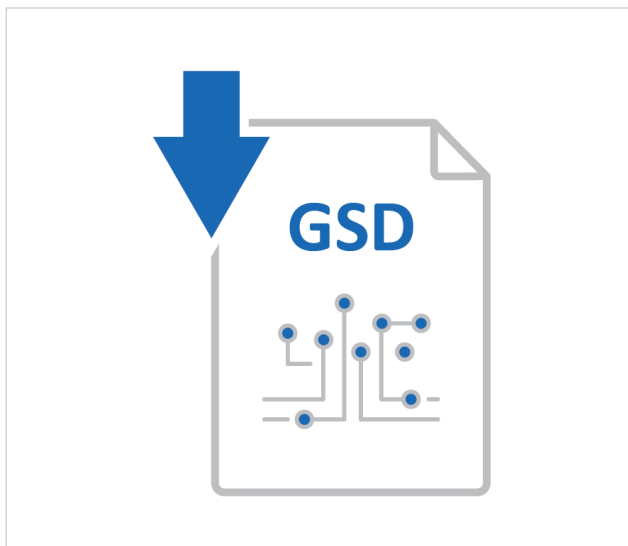

Option if the PLC program requires a GSD (General Station Description) file.

On the **PROFIBUS** page: Download the GSD file to your PC.

**In the PLC program:****1. Import product file**

Option if the PLC program requires a GSD (General Station Description) file.  
Import the GSD file into your PLC project.

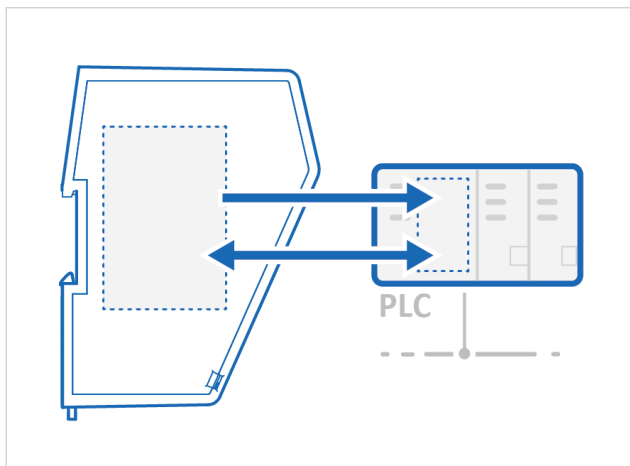
**2. Configure the communication**

Configure the PLC to communicate with the Communicator according to the I/O data map created in the Communicator.

## 7.4. Verify Operation

### 1. Apply the configuration

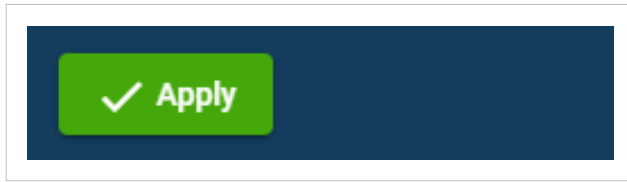

When you have completed and verified the configuration, click **Apply** for the settings to take effect.

### 2. Verify status and LED indications

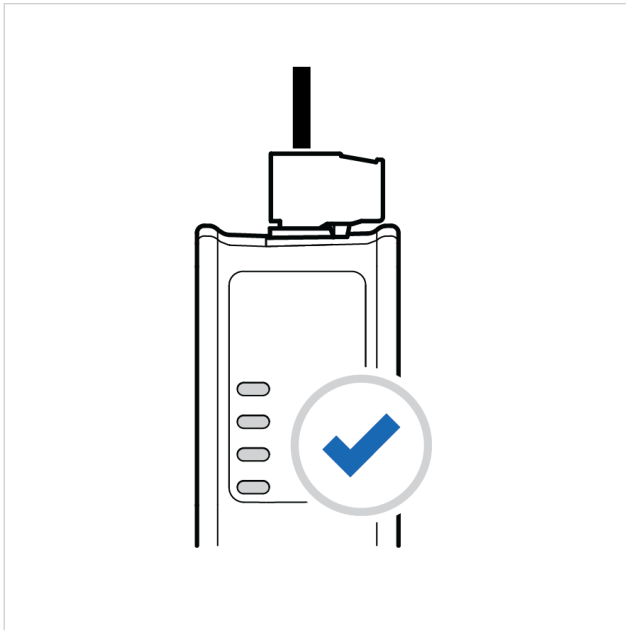

On the **Home** page:

Monitor the Communicator, network and node status.

You can also view the Communicator LED indications remotely.

### 3. Verify and monitor communication



In **Diagnostics**, use the:

- **Serial RS-232/485** page to verify that the serial commands are sent and received by the Communicator.
- **I/O data** page to monitor how the data flow between the **Serial RS-232/485** side and the **PROFIBUS** side, including any configured endian conversions.
- **Event log** page to detect failures and unexpected behavior over time.

## 8. Communicator Configuration

This section is intended to give you detailed information about the tasks you need to perform to setup a new Communicator configure.

For a more brief overview of the configuration steps, please refer to the [Configuration Quick Guide \(page 33\)](#).

### 8.1. Connect the Communicator

#### Procedure

##### Connect to Serial RS-232/485 network and PROFIBUS network

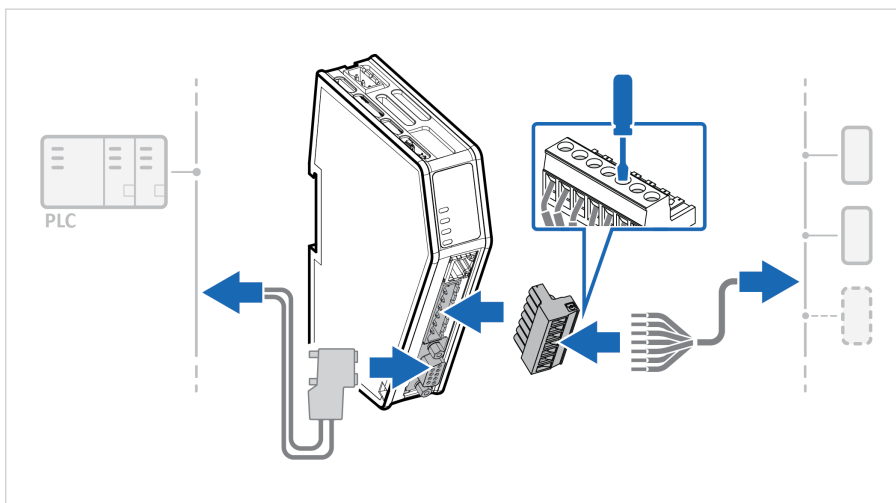

1. Connect the Communicator to the high level network.
2. Connect the Communicator to the subnetwork.

##### Connect to PC and Power

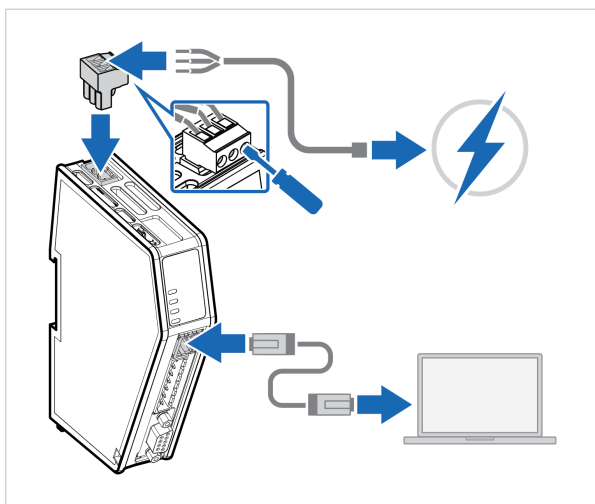

1. Connect an Ethernet cable between the Communicator and your PC.
2. Connect the Communicator to a power supply.

## 8.2. Access the Built-In Web Interface from HMS IPconfig

### Before You Begin

Download the software application HMS IPconfig installation files and user documentation from [www.anybus.com/support](http://www.anybus.com/support).



#### NOTE

The Communicator default IP address is 192.168.0.10.



#### NOTE

To access the Communicator built-in web interface, ensure that Port 80 TCP is open in your Firewall. This applies to any Firewall between the web browser and the gateway.



#### NOTE

To access the Communicator built-in web interface from HMS IPconfig, ensure that Port 3250 UDP is open in your PC Windows Firewall.



#### NOTE

Ensure that the security switch is unlocked. HMS IPconfig cannot configure the Communicator if the security switch is locked.



#### TIP

When you have accessed the Communicator built-in web interface, you can change the IP settings for the Communicator configuration port on the **System > Configuration port** page.

### Procedure

1. Install HMS IPconfig on your PC.
2. Open HMS IPconfig.

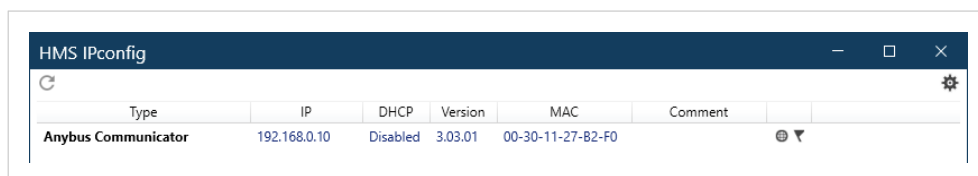

- HMS IPconfig automatically starts scanning for compatible and active HMS devices.
  - Found HMS devices are added to the device list.
3. To open the settings pane, click on the Communicator in the device list.

4. Change the Communicator configuration port IP address to one within the same IP address range as your PC.

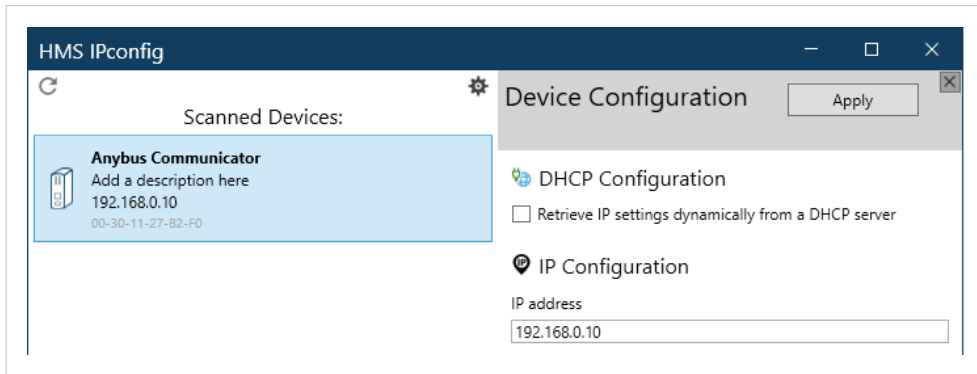

5. To open the **Open web page** built-in web interface, click Communicator.

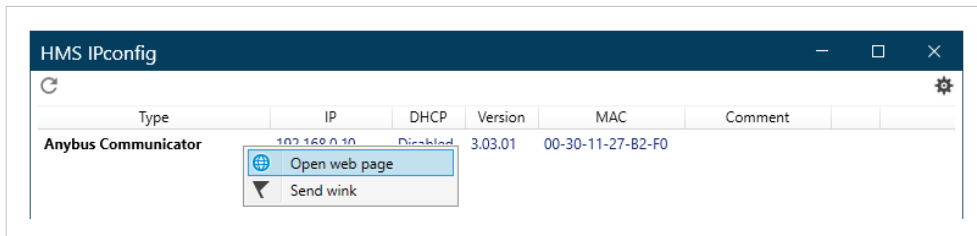

### Result

You are redirected to the Communicator built-in web interface **Home** page.

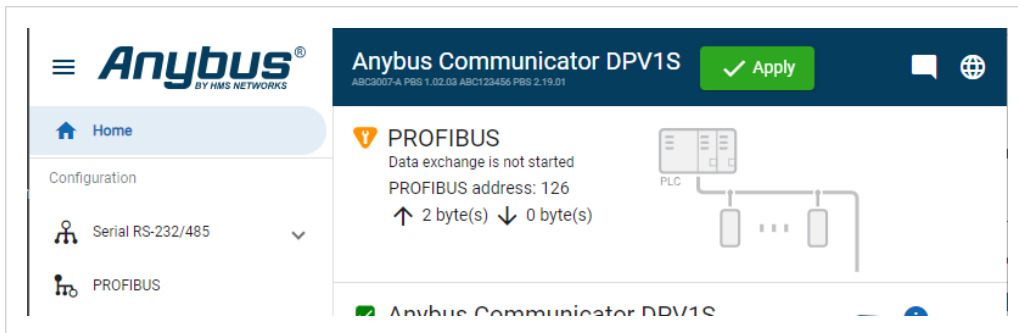

## 8.3. Access the Built-In Web Interface from a Web Browser

### Before You Begin

**NOTE**

The Communicator configuration port default IP address is 192.168.0.10.

**NOTE**

To access the Communicator built-in web interface, ensure that Port 80 TCP is open in your Firewall. This applies to any Firewall between the web browser and the gateway.

**NOTE**

When you change to a static IP address on your computer, internet access may be lost.

**TIP**

When you have accessed the Communicator built-in web interface, you can change the IP settings for the Communicator configuration port on the **System > Configuration port** page.

### Procedure

1. On the PC accessing the Communicator built-in web interface, set a static IP address within the same IP address range as the Communicator IP address.



2. Open a web browser.
3. Click to select the **Address bar** and enter the Communicator IP address.

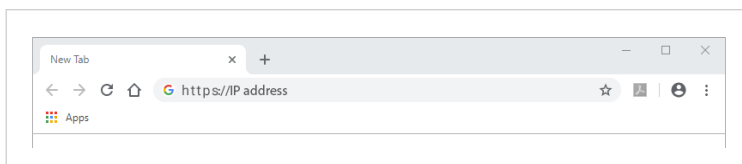

4. To open the built-in web interface **Home** page, press **Enter**.

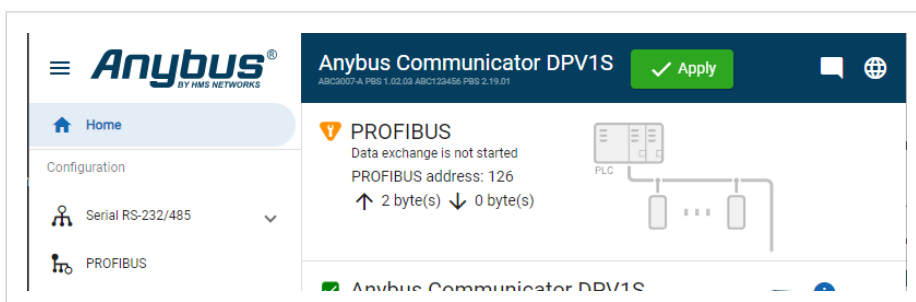

## 8.4. Communicator Built-In Web Interface Overview

Use the Communicator built-in web interface to configure, maintain and troubleshoot the Communicator.

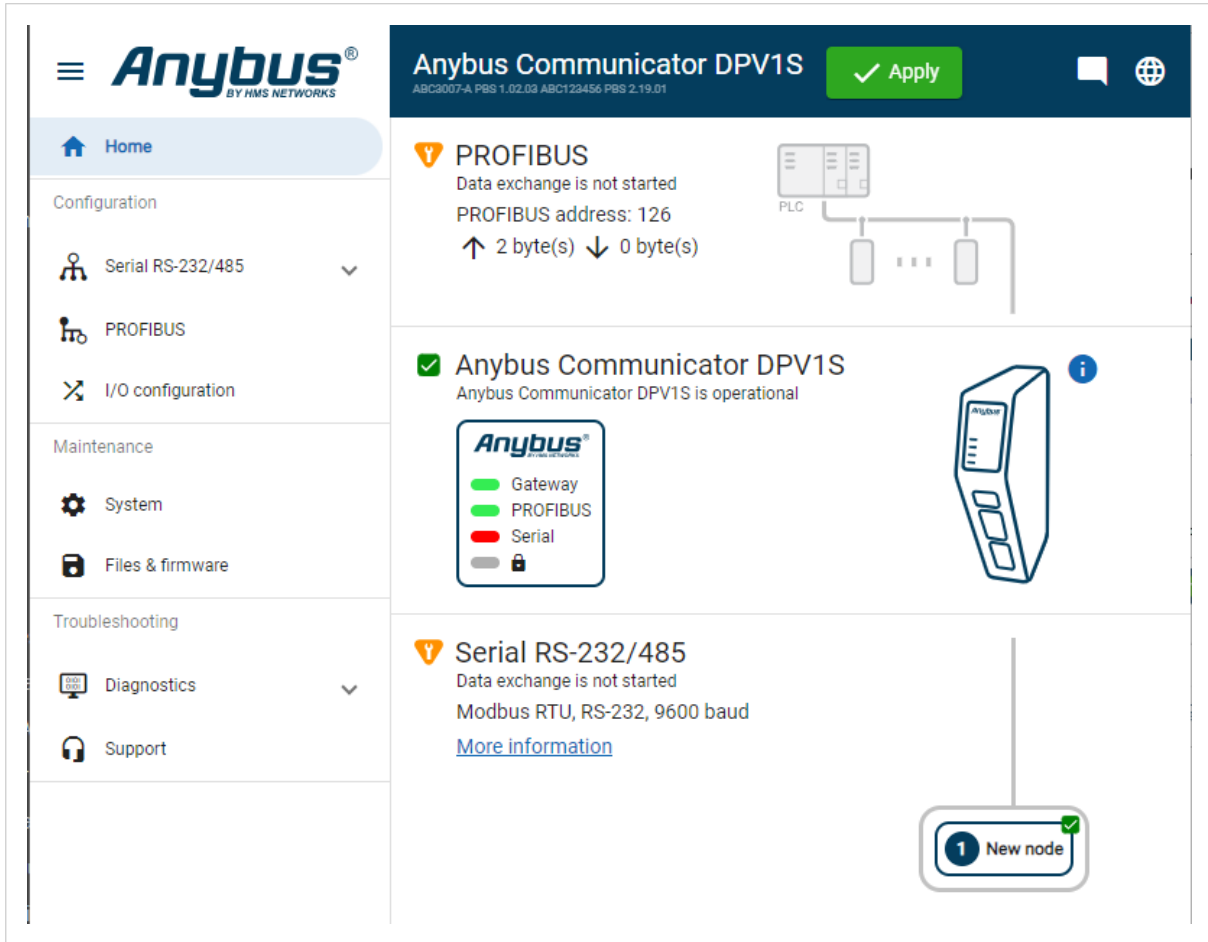

Figure 25. The Communicator built-in web interface Home page

Menu item	Description
Home	View the Communicator, network and node status.
Apply	After configuration changes are made and verified, press Apply to make the settings take effect.
Serial RS-232/485	Serial Subnetwork with Nodes. Select a Serial protocol, use Modbus RTU standard transactions or create your own transaction templates. Configure communication and add nodes and commands.
PROFIBUS	High Level Network with Client. Configure I/O Size and PROFIBUS address.
I/O configuration	View the added commands mapped to the Communicator internal memory area.
System	Define how the device should behave if a serious error occurs. Configure the Communicator configuration port IP settings.
Files & firmware	Save settings in a configuration files, upload configuration files and upgrade firmware.
Diagnostics	Monitor and troubleshoot the Communicator.
Support	Contains Communicator product information, Anybus contact information, link to Anybus support website, and product file for download. Here you can generate a support package with product information, to send to your Anybus support technician.

## 8.5. General Subnetwork Settings

### 8.5.1. Communication Serial Protocol

#### Before You Begin

Before starting the configuration, select the Serial protocol you want to use:

- **Modbus RTU**, Default setting: Use for serial devices that conform to the Modbus communication specification.
- **Custom Request/Response**: Create your own custom request/response transactions. The transactions can be based on the Modbus communication specification or fully customized.
- **Custom Produce/Consume**: Create your own custom produce/consume transactions.



#### IMPORTANT

When changing the serial protocol, all settings are reset to default and all added nodes, transactions, and transaction templates are deleted.

#### Procedure

On the **Communication** page:

1. To choose a **Serial protocol**, select **Modbus RTU**, **Custom Request/Response** or **Custom Produce/Consume**.

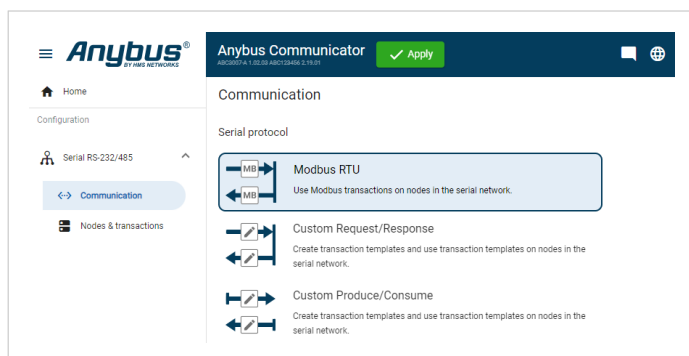

Figure 26. Communication, Serial protocol

2. To confirm the selected protocol, click **Change serial protocol**.

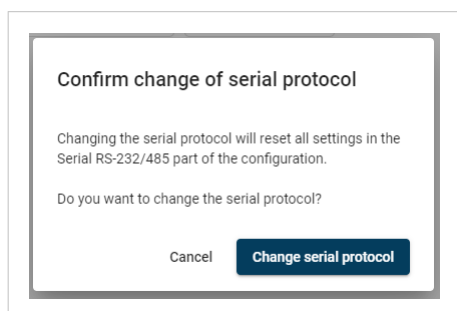

Figure 27. Confirm change of serial protocol

#### Apply Configuration

To apply the settings, click **Apply** in the built-in web interface header and follow the instructions.

### 8.5.2. Communication Basic Settings

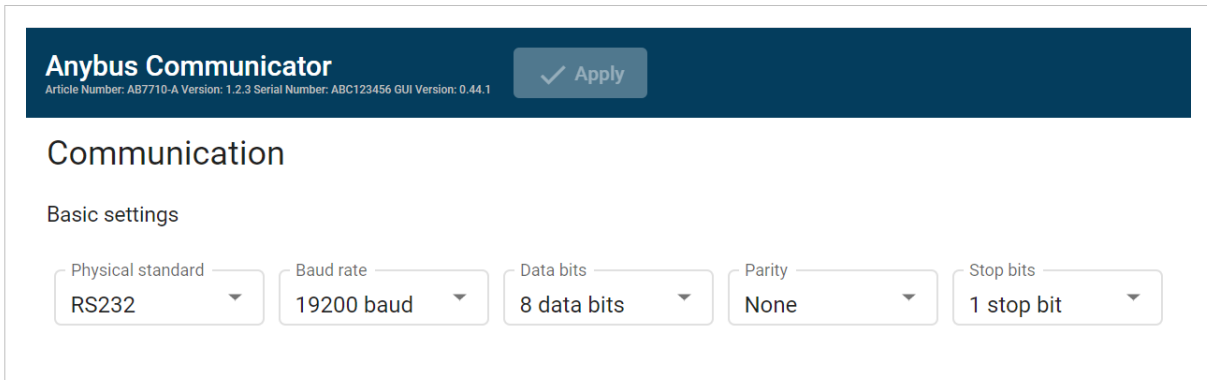
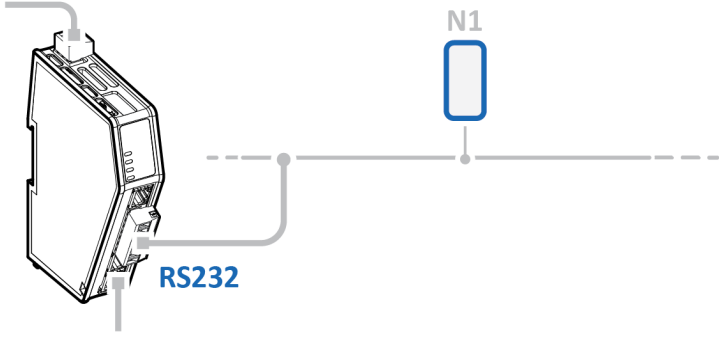
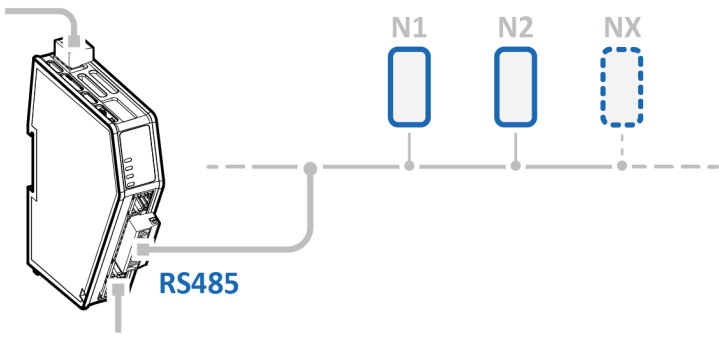

Figure 28. Communication, Basic settings

#### Physical standard

Specify the physical interface type for the device connected to the Communicator.

- Select a physical standard from the **Physical standard** drop-down menu.

Setting	Value	Description
Physical standard	RS-232, Default standard	Use RS-232 when one single node is connected to the subnetwork. 
	RS-485	Use RS-485 when multiple nodes are connected to the subnetwork. 

#### Baud rate

Specify the baud rate; the serial transfer speed, maximum bits per second.

Select a baud rate value from the **Baud rate** drop-down menu.

Setting	Value
Baud rate	1200 baud
	1800 baud
	2400 baud
	4800 baud
	9600 baud, Default value
	19200 baud
	35700 baud
	38400 baud
	57600 baud
	115200 baud
	128000 baud

### Data bits

Data bits is the number of bits used in the data representation of characters in the telegrams.

The rate for Modbus RTU is 7 data bits or 8 data bits. The default setting is 8 data bits.

### Parity

Specify if parity should be used to detect errors in the data.

Select parity value from the **Parity** drop-down menu.

Setting	Value	Description
Parity	None, Default value	No parity checking Parity bit is not transmitted
	Odd	Odd parity checking
	Even	Even parity checking

### Stop bits

Specify the number of stop bits used to indicate the end of data transmission.

Select a stop bits value from the **Stop bits** drop-down menu.

Setting	Value
Stop bits	1 stop bit, Default value
	2 stop bit

### Apply Configuration

To apply the settings, click **Apply** in the built-in web interface header and follow the instructions.

### 8.5.3. Communication Advanced Settings

#### Inter-Telegram Timeout Mode Settings

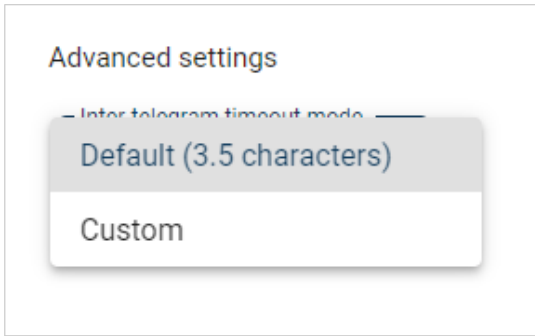

Figure 29. Advanced settings, Default (3.5 characters)

By default, Inter-telegram timeout mode Default (3.5 characters) is used.

This is according the Modbus RTU standard, which advocates the use of a silent period equivalent to 3.5 characters between each message. The silent period is used to find out where one message ends and the next begins.

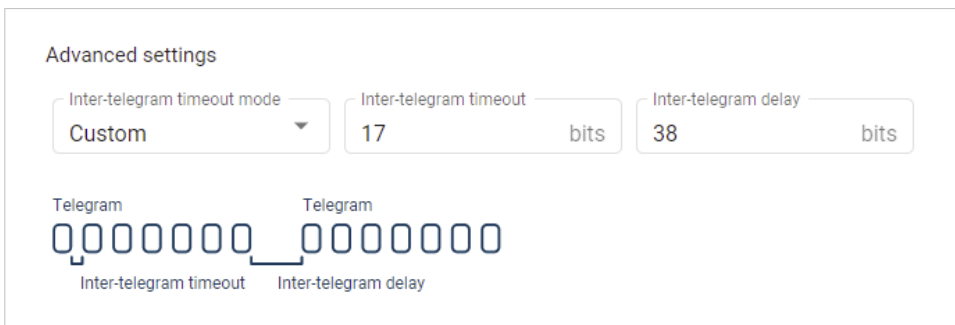

Figure 30. Custom settings, Inter-telegram timeout and Inter-telegram delay

You can use Custom settings to set the desired Inter-telegram timeout and Inter-telegram delay.

The following must be applied on all nodes:

- The time between two adjacent characters in the same telegram must be less than Intertelegram timeout.
- The time between two characters in two different telegrams the same or more than Intertelegram delay.

### About Inter-Telegram Start and End Character

This topic describes scenarios for using Start character and End character.

#### Example 4. Both Start Character and End Character Disabled

Default setting, no **Start character** or **End character** is used.

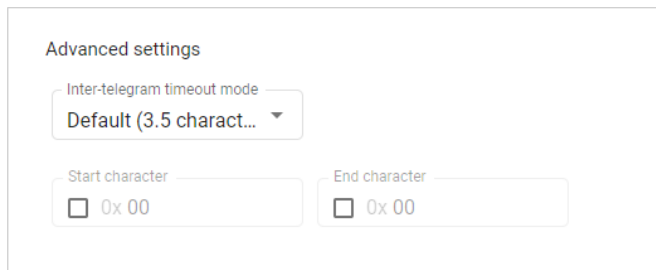

Figure 31. Start character and End character are Disabled

The size of the telegram is defined between two inter-telegram delays.

Standard **Inter-telegram delay**: 3.5 characters

**Inter-telegram delay** is set in the Advanced settings, see [Inter-Telegram Timeout Mode Settings \(page 51\)](#).

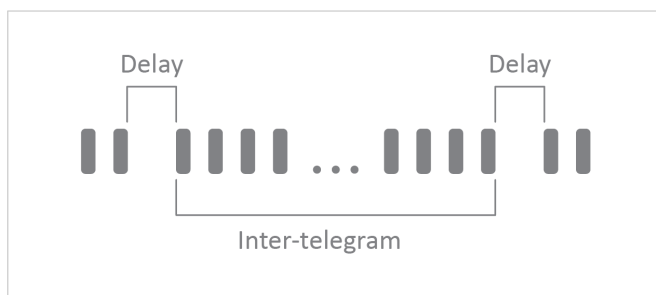

Figure 32. Data stream without Start and End characters

Example 5. Start Character Enabled and End Character Disabled

**Start character** is used.

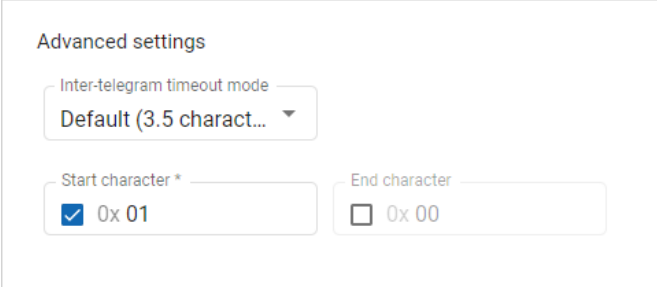

Figure 33. Example: Start character Enabled, Hex value 0x01

First, a start character is identified in the data stream, then the inter-telegram follows. The inter-telegram ends when an inter-telegram delay is identified in the data stream.

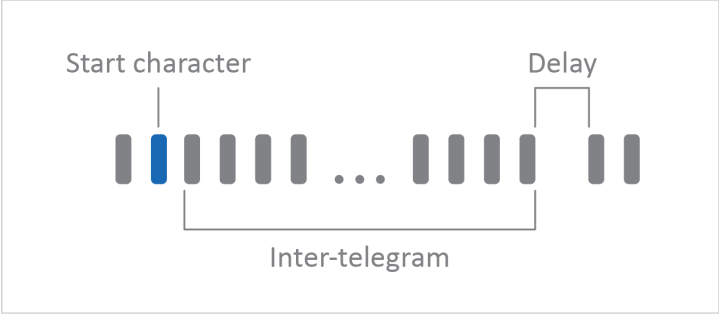

Figure 34. Data stream with Start character

Example 6. Start Character Disabled and End Character Enabled

**End character** is used.

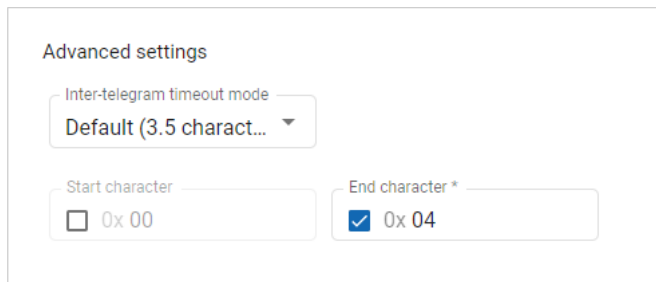

Figure 35. Example: End character Enabled, Hex value 0x04

First, an inter-telegram delay is identified in the data stream, then the inter-telegram follows. The inter-telegram ends when an end character is identified in the data stream.

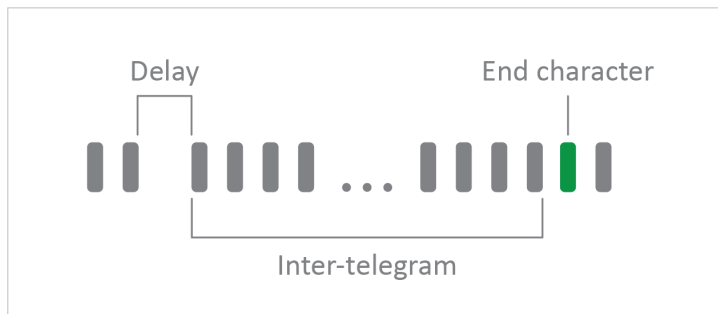

Figure 36. Data stream with End character

**Example 7. Both Start Character and End Character Enabled**

Both **Start character** and **End character** is used.

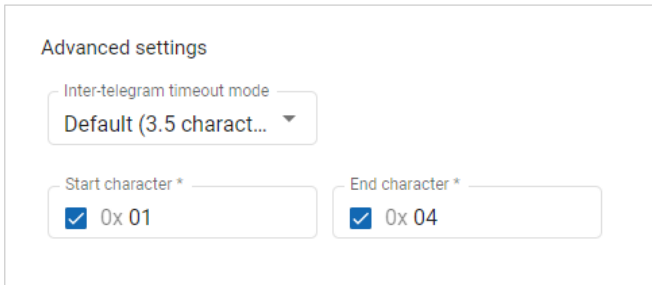

Figure 37. Example: Start character Enabled, Hex value 0x01 and End character Enabled, Hex value 0x04

First, a start character is identified in the data stream, then the inter-telegram follows. The inter-telegram ends when an end character is identified in the data stream.

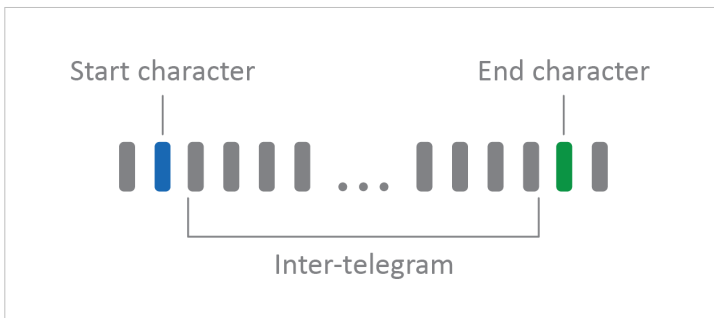

Figure 38. Data stream with Start character and End character

### Inter-Telegram Start and End Character

**Start character** and **End character** is only valid for the **Custom Produce/Consume Serial protocol** mode; **Produce** or **Consume** transactions, see [Communication Serial Protocol \(page 48\)](#).

**NOTE**

**Inter-telegram timeout mode Custom** settings for **Inter-character timeout** and **Inter-telegram delay** still apply if **Start character** and/or **End character** is enabled.

**NOTE**

If a inter-telegram exceeds the maximum allowed transaction frame size of 1500 bytes, the telegram is invalid and discarded.

### Start and End character Use Case Example

In serial channel data stream, there is a **Consume** transaction for which you want to obtain the content between two defined characters as an Inter-telegram.

### Procedure

Advanced settings

Inter-telegram timeout mode  
Default (3.5 charact... ▼

Start character  0x 00

End character  0x 00

Figure 39. Start and End character settings

1. Navigate to the **Serial RS-232/485 Communication** page.
2. Select the **Custom Produce/Consume Serial protocol** mode.
3. To enable **Start character** and/or **End character**, select the checkbox(es).
4. Enter the decried character hexadecimal value(s) for the Inter-telegram.

### Result

For **Produce** transactions, a start and/or end character is added to the inter-telegram when it is sent.

## 8.6. About Transaction Templates

This section applies when the Custom Request/Response or Custom Produce/Consume serial protocol is applied, refer to [Communication Serial Protocol \(page 48\)](#).

### 8.6.1. Transaction Template Example

#### Custom Request/Response

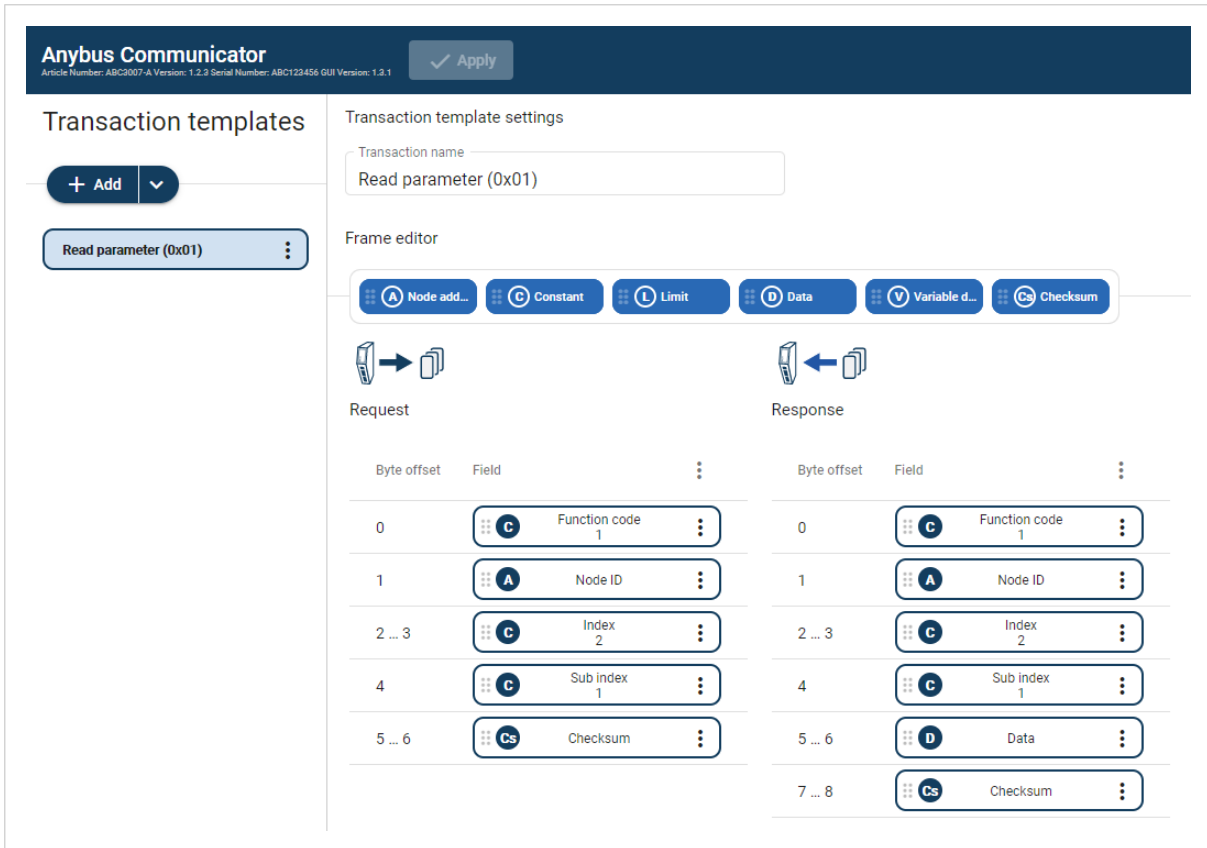

Figure 40. Request/Response transaction template example

The transaction named Read parameter (0x01) consists of a number of frame fields.

In the Request field there are three Constants, a Node address and a Checksum field.

In the Response field there are three Constants, a Node address, a Data field and a Checksum field.

### Custom Produce/Consume

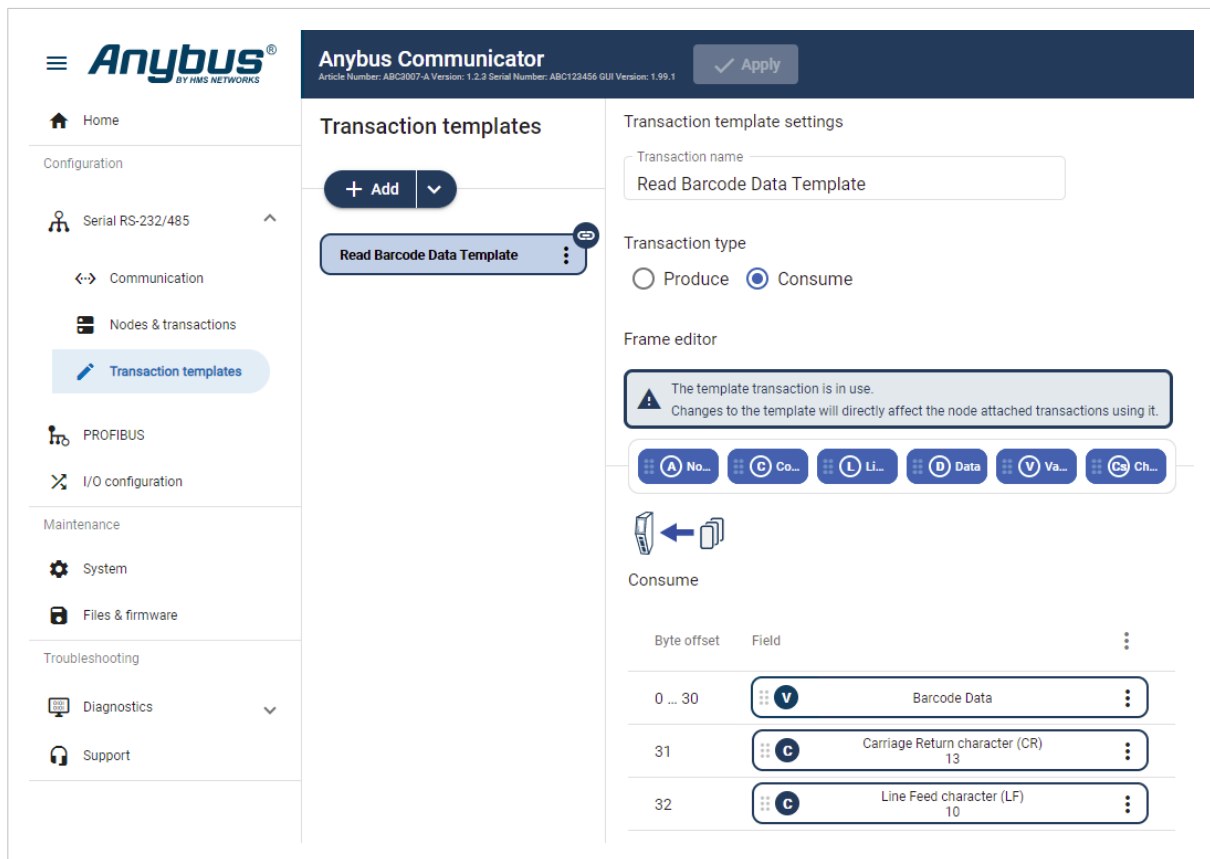

Figure 41. Produce transaction template example

The transaction named Read Barcode Data Template consists of a number of frame fields.

The Transaction type can be Produce or Consume. In this example the Transaction type Consume is selected.

In the frame field we have added one Variable data field and two Constant fields.

### 8.6.2. Transaction Template Types

There are two types of transaction templates, Empty template and Modbus template.

#### Empty Template

When using the **Empty template**, you start with an empty transaction and build a desired structure by adding and arranging frame fields.

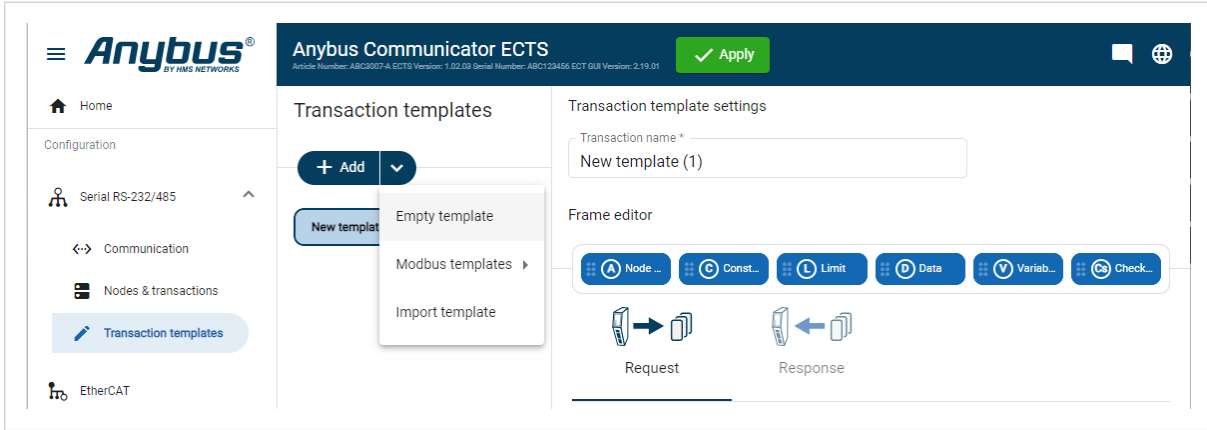

Figure 42. Transaction template, Empty template

For the produce/consume transactions you select; **Empty produce template** or **Empty consume template**.

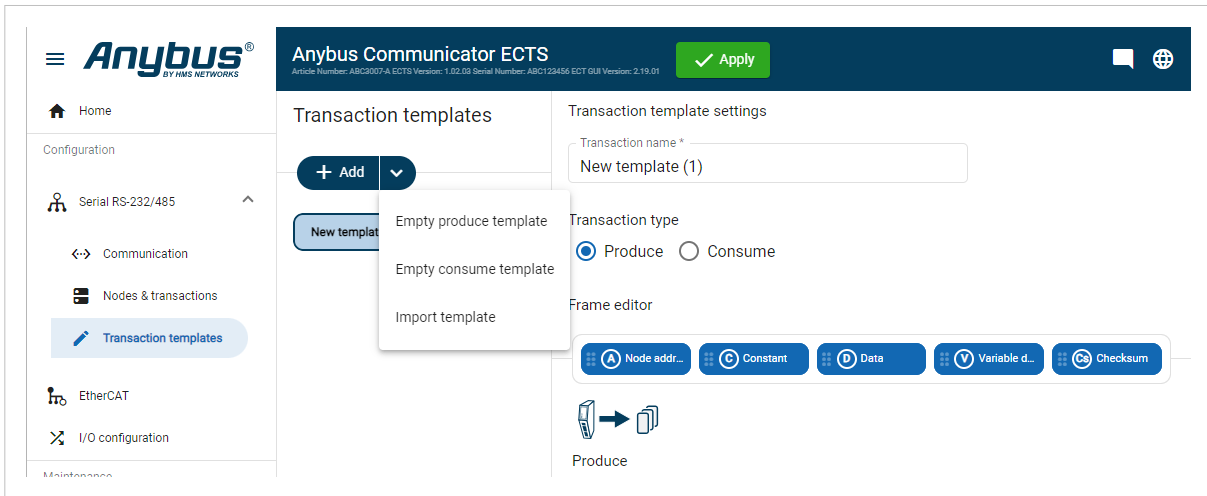

Figure 43. Transaction template, Empty Produce and Consume templates

#### Modbus Templates

Modbus templates are available for Custom Request/Response and Modbus RTU transactions.

When using the Modbus template, you first select the **Modbus template** from which you want to start.

You can then restructure the transaction by rearranging, adding or removing frame fields.

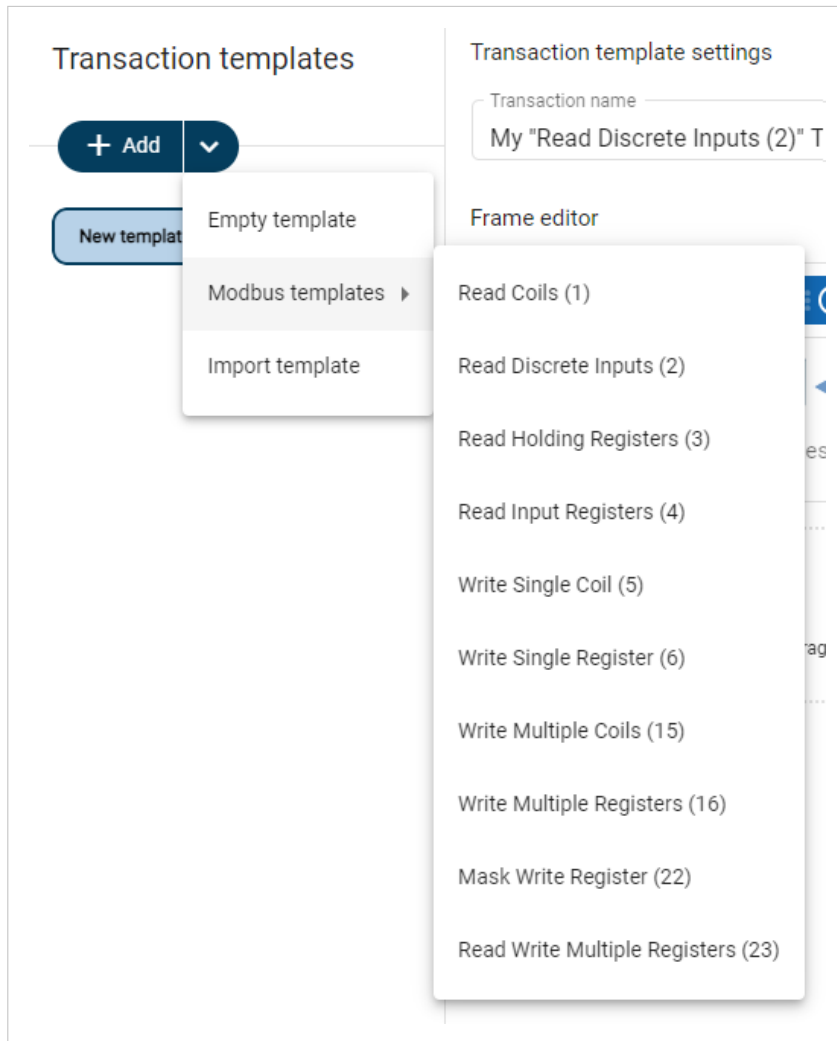
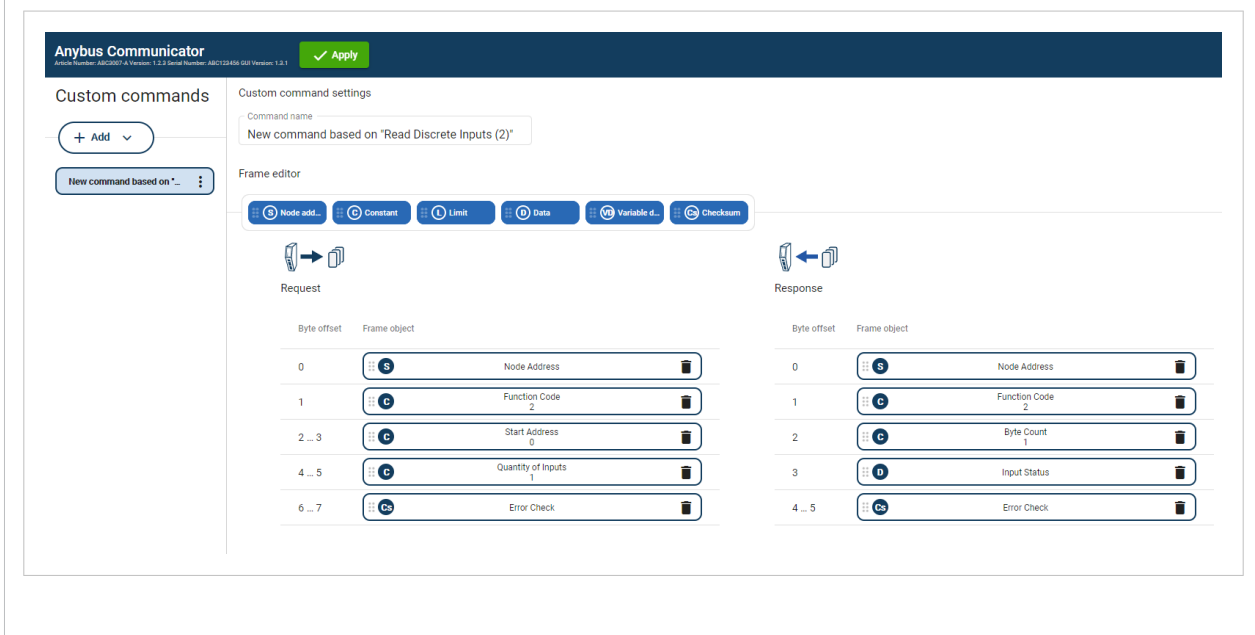

Figure 44. Transaction template, Modbus template

Example 8. New transaction template based on the Modbus template Read Discrete Inputs



### 8.6.3. Frame Field Types

Each transaction consists of frame fields which makes up the serial telegram frame.

Each frame field specifies how the Communicator shall interpret or generate a particular part of the telegram.

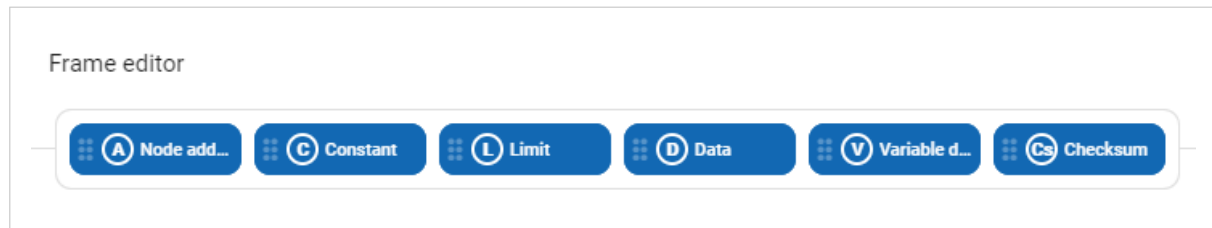

Figure 45. The following frame objects are available

#### Node address

Frame field representing the Node address of the Node.

A constant byte that holds a copy of the nodes address when the transaction is used by a node.

#### Constant

Constant frame fields are handled differently depending on the direction of the transaction.

- Produce/Request Transactions: The Communicator sends the value as it is without processing it.
- Consume/Response Transactions: The Communicator checks if the received byte/word/dword matches the specified value. If the message does not fit, it is discarded.

#### Limit



#### NOTE

Limit is not available for the Transaction Type Produce.

- Consume/Response Transactions: The Communicator checks if the received byte/word/dword fits inside the specified boundaries. If the message does not fit, it is discarded.

#### Data

Data frame fields are used to represent raw data as follows.

- Produce/Request Transactions: The specified data block is forwarded from the higher level network to the subnetwork.
- Consume/Response Transactions: The specified data block is forwarded from the sub-network to the high level network.

#### Variable data

Produce/Request Transactions:

- The specified data block will be forwarded from the higher level network to the sub-network.
- The control system must supply an End or Length character in order for the Communicator to know the size of the data block.
- The End- or Length-character itself may either be forwarded to the sub-network or discarded.

Consume/Response Transactions:

- The specified data block is forwarded from the sub-network to the higher level network.
- The End- or Length-character will be generated by the Communicator automatically (if applicable).

- The End- or Length-character itself may either be forwarded to the higher level network or discarded.

**Checksum**

Most serial protocols features some way of verifying that the data has not been corrupted during transfer.

The checksum frame field calculates and includes a checksum in a transaction.

## 8.7. Build Transaction Template

### Before You Begin

Ensure that you have applied the Custom Request/Response or Custom Produce/Consume serial protocol, refer to [Communication Serial Protocol \(page 48\)](#).

### 8.7.1. Add Transaction Template

#### Procedure

Add a transaction template:

1. In the web-interface left sidebar menu, click **Transaction templates**.

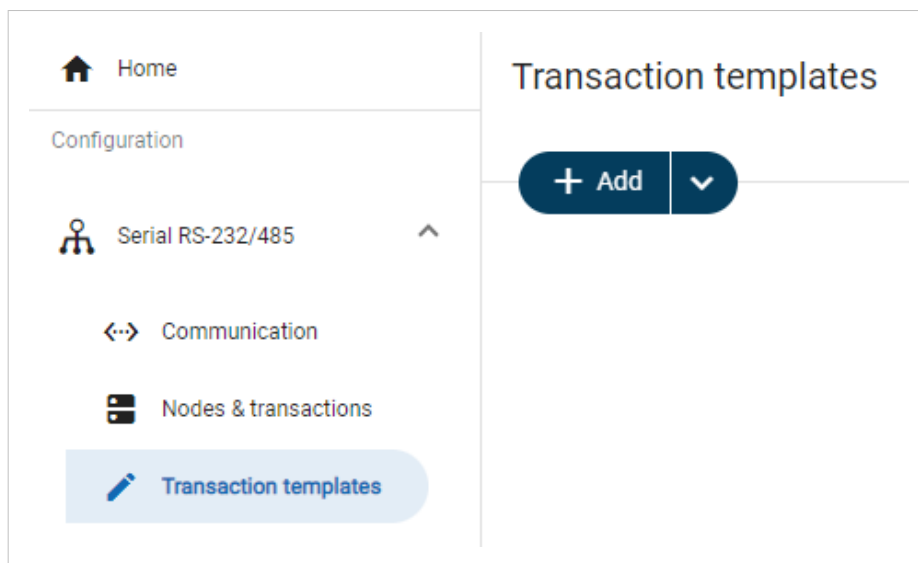

2. To select the template you want to use, click the **Add** drop-down button.

#### Options for the Custom Request/Response Protocol

- To add a new empty template without any frame fields, select **Empty template**.

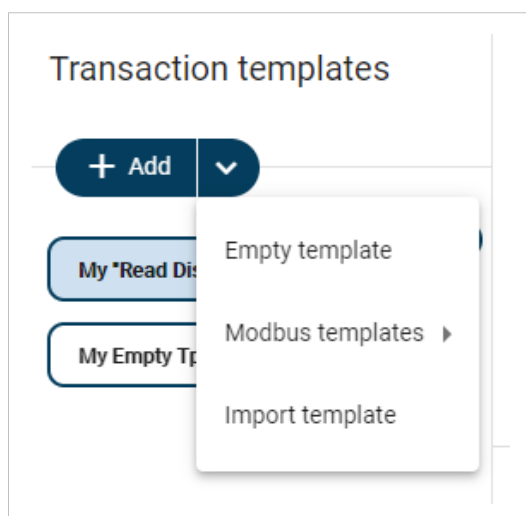

Example 9. A new empty request/response template is added to the transaction template list

The screenshot displays the 'Anybus Communicator' software interface. At the top, a dark blue header contains the product name 'Anybus Communicator', version information, and a green 'Apply' button. Below the header, the main workspace is divided into two columns. The left column, titled 'Transaction templates', features a '+ Add' button and a list containing one entry: 'New template (1)'. The right column, titled 'Transaction template settings', includes a text input field for the 'Transaction name' with the value 'New template (1)'. Below this is the 'Frame editor' section, which contains a horizontal toolbar with six buttons: 'Node add...', 'Constant', 'Limit', 'Data', 'Variable ...', and 'Checksum'. Underneath the toolbar are two drag-and-drop areas labeled 'Request' and 'Response', each with a 'Drop fields here' instruction and a note to 'Drag a field from the toolbar above.'

- To add a new template based on a standard Modbus transaction, select **Modbus templates** and then the desired Modbus transaction.

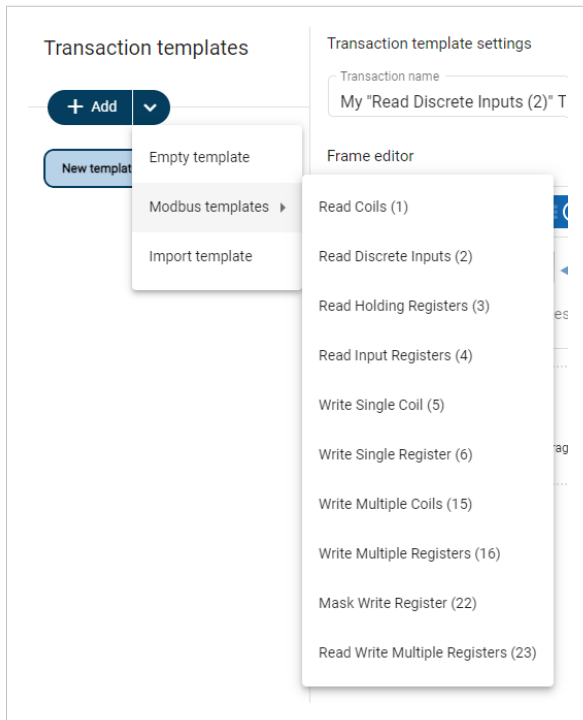

Example 10. A new request/response template based on “Read Coils (1)” is added to the transaction template list

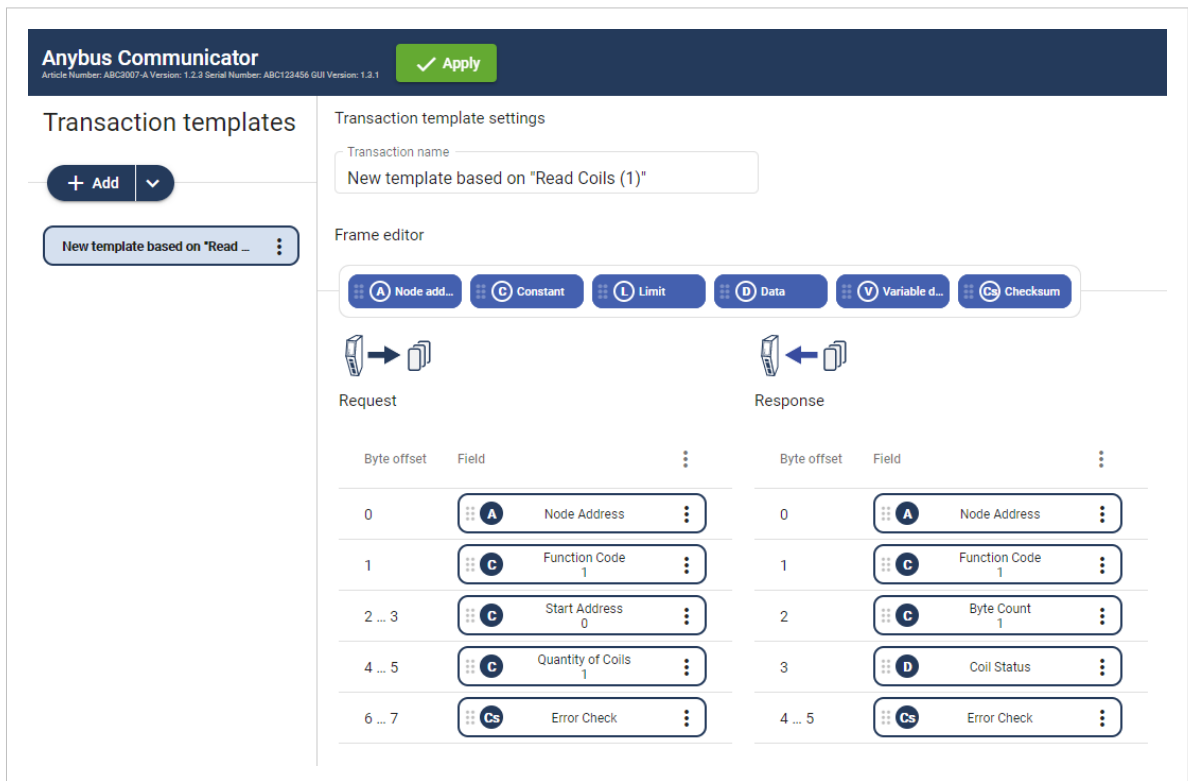

**Option for the Custom Produce/Consume Protocol**

- Select **Empty produce templates** or **Empty consume templates**.  
You can change the Transaction type after the transaction template is added.

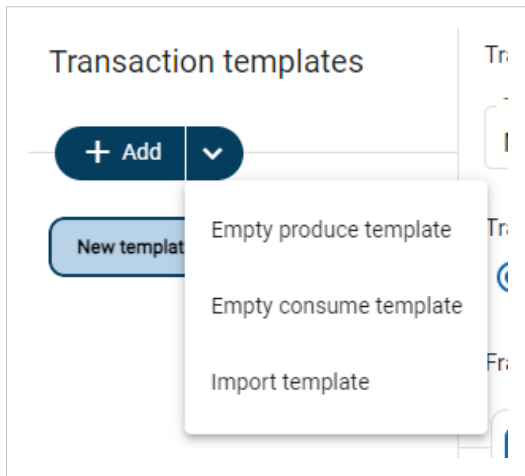

Example 11. A new produce template is added to the transaction template list

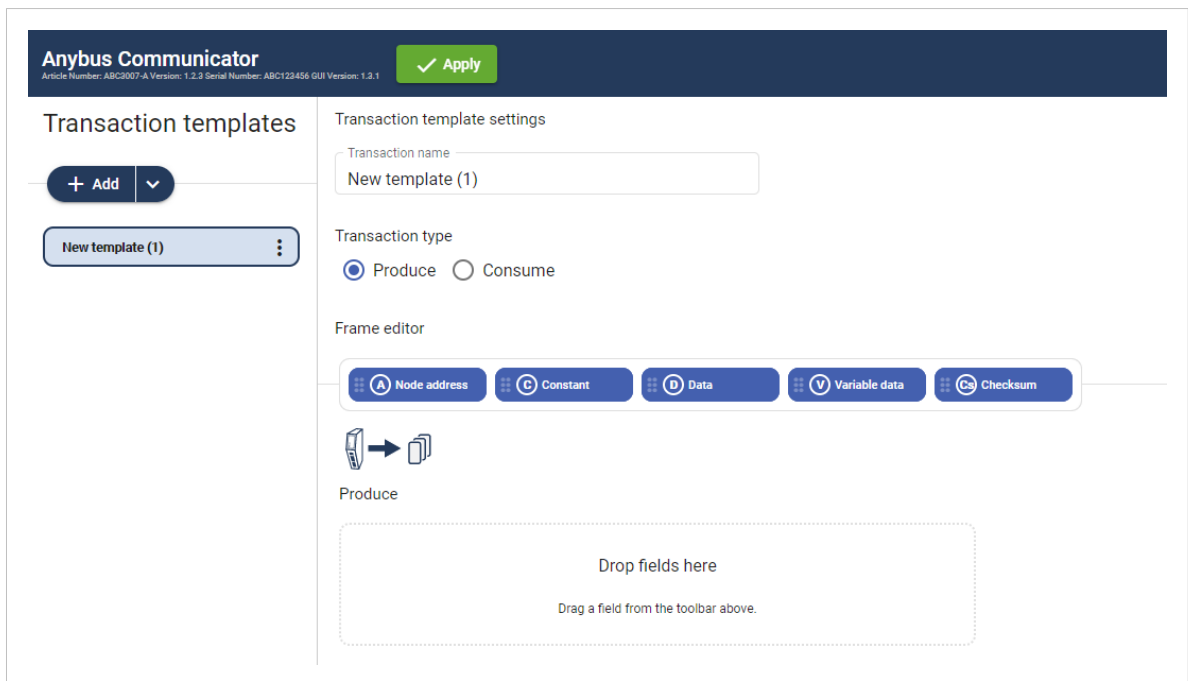

3. To apply the settings, click **Apply** in the web-interface header, and follow the instructions.

**To Do Next**

- Add frame fields to the transaction template, refer to [Add Frame Fields \(page 67\)](#).

## 8.7.2. Add Frame Fields

### Procedure

1. In the transaction template list, select a transaction template to add frame fields to.

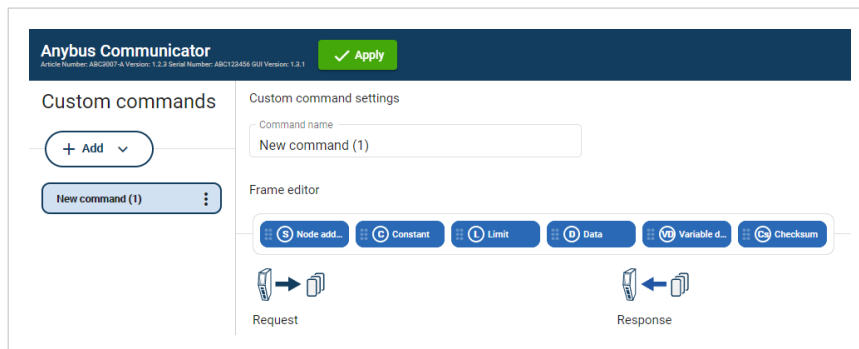

Figure 46. Select transaction template

2. Build the transactions.

- To add frame fields: In the Frame editor frame fields menu, drag and drop the desired frame fields into the drag and drop fields.

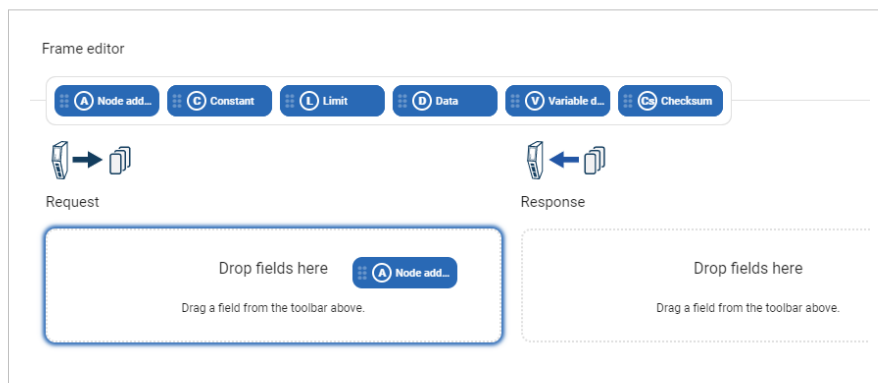

Figure 47. Add frame fields

- To duplicate a frame field: On the frame field that you want to duplicate, click the three dots icon and then click Duplicate.

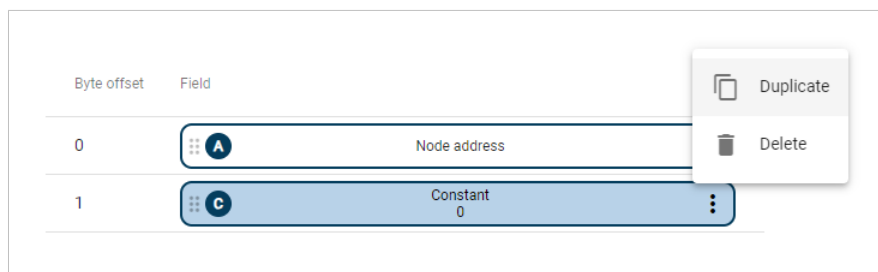

Figure 48. Duplicate frame fields

- To change the order of the frame fields: Drag and drop the frame fields in the list to change the order.

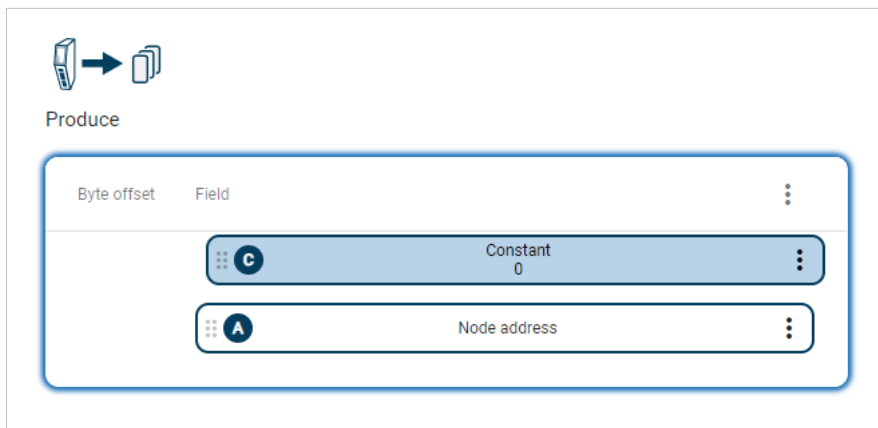

Figure 49. Change frame fields order

- To delete a frame field: On the frame field that you want to delete, click the **three dots icon**. Click **Delete** and then **Yes** to confirm.

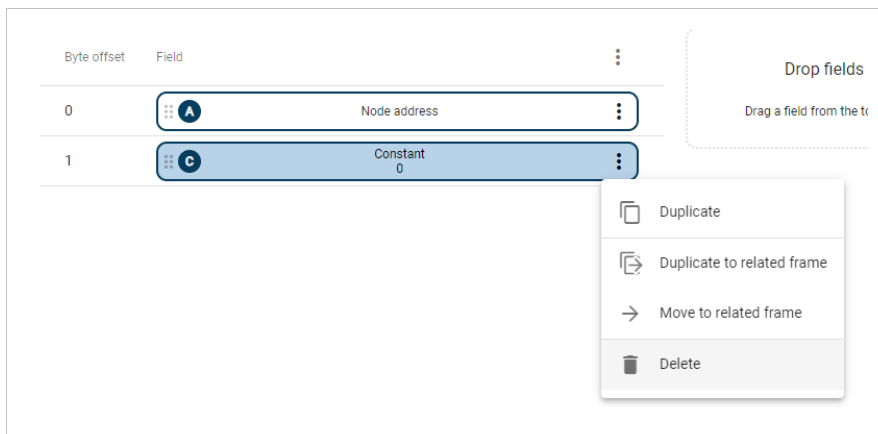

Figure 50. Delete frame field

3. To apply the settings, click **Apply** in the web-interface header, and follow the instructions.

**To Do Next**

- Configure the frame field settings, see [Configure Frame Field Settings \(page 69\)](#).

## 8.7.3. Configure Frame Field Settings

### Procedure

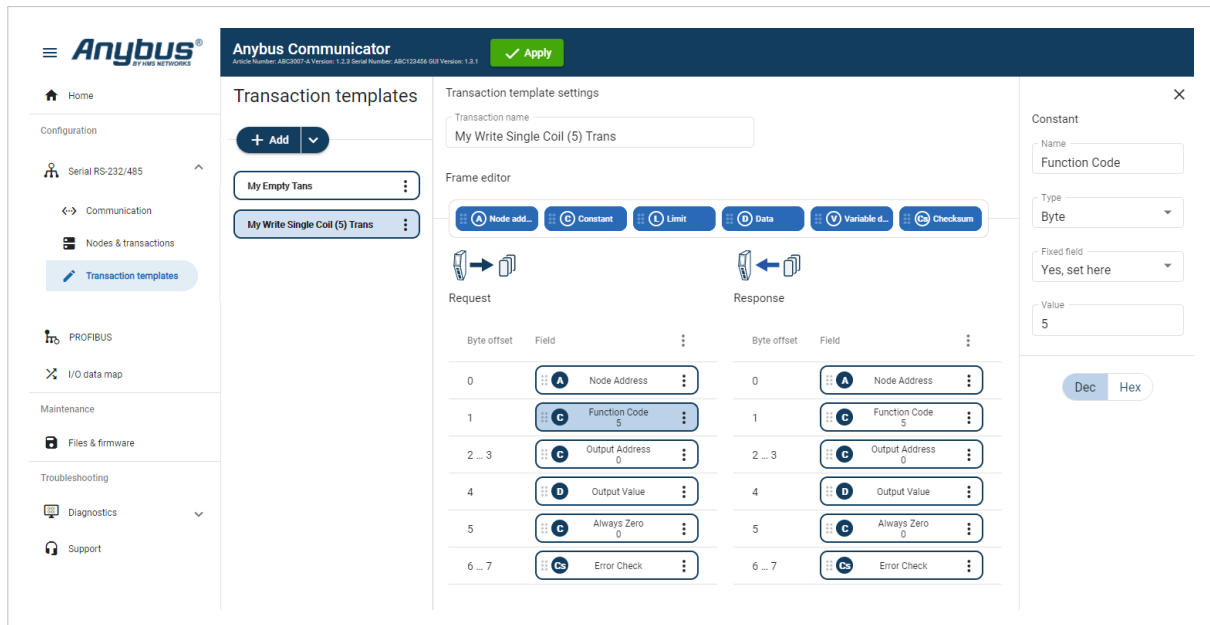

Figure 51. Frame Fields Settings

1. In the Transaction templates list, select a transaction template to configure.
2. In the Transaction template settings select a Field to configure. The Field sidebar opens, on the right side of the screen.
3. Configure the **Field** settings.

#### Node address

- Frame field representing the Node address of the node. A constant byte that holds a copy of the nodes address when the transaction is used by a node.
- When the transaction template is used by a node, the Node address field will automatically be replaced with the actual node address of the node.

#### Constant

- **Name:** You can name the Frame Field to make it easier to identify.
- **Type:** Specify the number of bytes in the frame. Select Byte (1 byte) (Default), Word (2 bytes), Double word (4 bytes), Array of bytes or String.
- **Endianness:** Select Big-endian (Default) or Little-endian.
- **Fixed field\*:** Select Yes, set here (Default) or No, set when used.
- **Length:** Valid for Array of bytes. Enter a byte offset value between 0 and 32 byte. Default value is 1 byte. Enter a Value for each Byte (0–31).
- **Value:** The value of the Constant in the frame. Enter a value between 0 (Default) and 255.
- **Min value:** Specify the minimum value that can be set when the template is used.
- **Max value:** Specify the maximum value that can be set when the template is used.
- **Default value:** Default value set when the template is used.

## Limit



### NOTE

Limit can only be added as a Response frame field.

- **Name:** You can name the Frame Field to make it easier to identify.
- **Type:** Specify the number of bytes in the frame. Select Byte (1 byte) (Default), Word (2 bytes), Double word (4 bytes).
- **Endianness:** Select Big-endian (Default) or Little-endian.
- **Min value:** The lowest value of the limit range.
- **Max value:** The highest value of the limit range.
- **Base number system:** Select Decimal Dec (Default) or Hexadecimal Hex.

## Data

- **Name:** You can name the Frame Field to make it easier to identify.
- **Fixed field\*:** Select Yes, set here (Default) or No, set when used.
- **Length:** Enter a value between 1 (Default) and 512 bytes.
- **Min length:** Specify the minimum length that can be set when the template is used.
- **Max length:** Specify the maximum length that can be set when the template is used.
- **Default length:** Specify the default length that can be set when the template is used.

## Variable data

- **Name:** You can name the Frame Field to make it easier to identify.
- **Fixed field\*:** Select Yes, set here (Default) or No, set when used.
- **Minimum payload length:** Specify the minimum payload length that can be set when the template is used.
- **Maximum payload length:** Specify the maximum payload length that can be set when the template is used.
- **Default max payload length:** Specify the default payload length that can be set when the template is used.
- **Data delimiter:** Specify how to detect/define the length of the variable data of the high level network. Select Byte counter, End pattern or None (Default).  
For information about End- and Length character, see [Data Delimiter and Subnet Delimiter Options \(page 72\)](#).
- **Subnet delimiter:** Specify how to detect/define the length of the variable data of the serial subnetwork. Select Byte counter, End pattern or None (Default).  
For information about End- and Length character, see [Data Delimiter and Subnet Delimiter Options \(page 72\)](#).
- **End pattern:** When a **Data delimiter** or **Subnet delimiter** is set to End pattern, specify the value defining the end of the payload.
- **Fill padding:** Fill up unused data mapped to the high level network or the general area with a field padding value.  
To deactivate/activate Fill padding, click the slide toggle. When Fill padding is activated, enter a Fill padding value between 0 and 255.
- **Base number system:** Select Decimal Dec (Default) or Hexadecimal Hex.

## Checksum

- **Name:** You can name the Frame Field to make it easier to identify.
- **Checksum type:** Specify the algorithm used to calculate the checksum. Select CRC (CRC-16-IBM) (Default), LRC (ISO 1155:1978), XOR or ADD.
- **Start offset:** Specify the offset from where to start the checksum calculation. Enter a value between 0 (Default) and 511.

- **Error check type:** Specify how the checksum is converted. Select None (Default), One's complement or Select None, Two's complement.
- **Destination Representation:**  
Each byte represents two ASCII characters.  
Allowed characters: Digits 0-9 and Letters a-f  
The first two characters represent the 4 most significant bits of the byte. The second character represents the 4 least significant bits.  
Specify how the destination checksum is represented:
  - Binary (Default): Data is transmitted and received as-is, no pre- or post-processing is performed.
  - ASCII (Lower case): Received telegrams are case insensitive and sent telegrams are lowercase.
  - ASCII (Upper case): Received telegrams are case insensitive and sent telegrams are uppercase.

#### About Fixed field\*

- **Yes, set here:** The Value set here is fixed and cannot be changed when the transaction is used on a node. The value must be updated in the transaction template.
- **No, set when used:** The Default value set here can be edited when the transaction is used on a node. The allowed range is the min/max values.

#### Total size including delimiters:

- High Level Network: 1 byte(s)
- Subnetwork: 1 byte(s).

4. Repeat step 1 to 3 until you have configured all the desired frame objects.

#### Apply Configuration

To apply the settings, click **Apply** in the built-in web interface header and follow the instructions.

### 8.7.4. Data Delimiter and Subnet Delimiter Options

In a variable data object, the length of the data field may vary depending on the type of data being read in a specific case.

In order to present the variable data correctly on the corresponding network, the length of the data field must be identified.

In a Variable data object, there are three ways to identify the data length; by length character, end character or length of message.

#### Data delimiter - Data is forwarded From the Communicator to the PLC

The Communicator can be configured to forward data as process data.

Different Data delimiter options can be used for data sent from the subnetwork to the Communicator and for data forwarded from the Communicator to the high level network, to fit the requirements in the PLC.

In most cases, when a stream of data is sent from the Communicator to the PLC the Byte counter (length character) or End pattern (end character) format is used.

#### Subnet delimiter - Incoming Data From a Serial Node to the Communicator

The Communicator can be configured to expect data from one of the three Subnet delimiter options; Byte counter, End pattern or None.

If the incoming data match the Subnet delimiter format the data is captured and the data section is forwarded to the high level network.

If the incoming data do not match the Subnet delimiter format, the data is ignored and will be matched with the next consume transaction.

#### Transaction Template Variable Data Settings

Figure 52. Transaction template variable data settings

1. Select a desired **Variable data** object.
2. In the **Data delimiter** and/or **Subnet delimiter** drop down menu, select one of the following options.

### Data delimiter and/or Subnet delimiter options

- Byte counter

The data packet consists of a length character, indicating the length of the data section, followed by the variable data object itself. In order to copy the exact data size from the transaction message, the length of the variable data object is first identified.

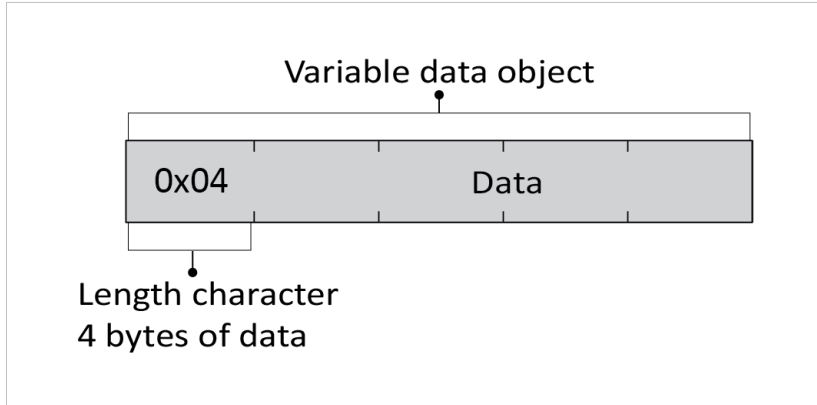

- End pattern

The package consists of a data section followed by an end character to indicate where the data section ends. End pattern is used to define whether the delimiter is an end character or an end pattern, which depends on whether the message is forwarded from the subnetwork or sent as process data.

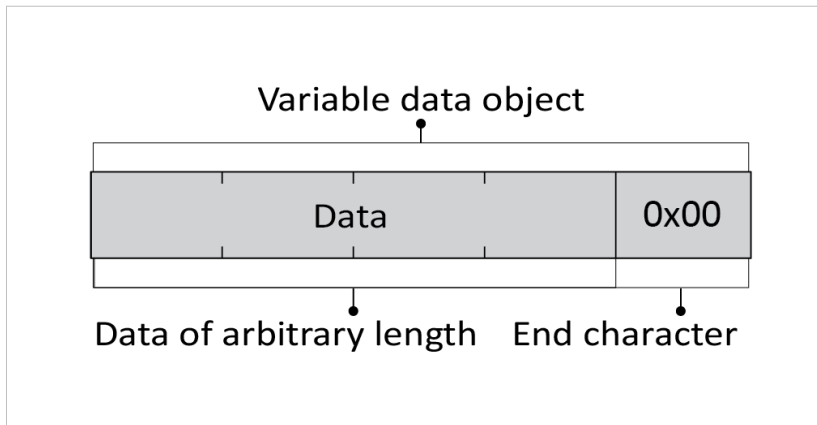

- None (Default)

The package contains only the data section. By measuring the total length of the message, the length of the data section can be calculated.

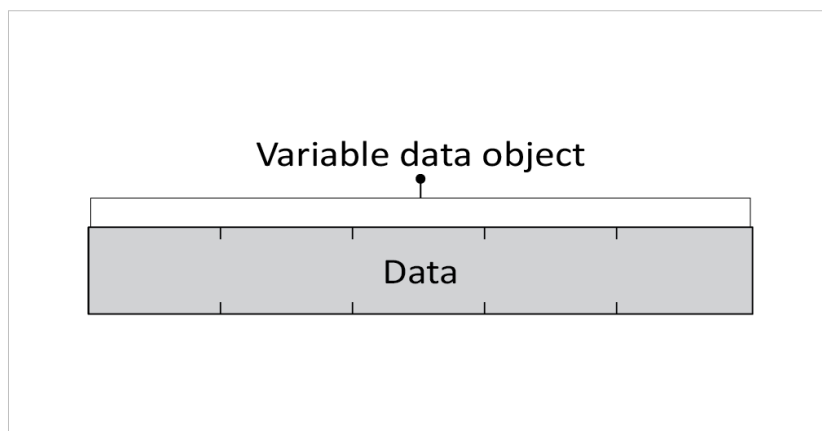

3. When a delimiter is set to End pattern: In the **End pattern** field, enter the value that will define the end of the payload.

End pattern is used to define whether the delimiter is an end character or an end pattern, which depends on whether the message is forwarded from the subnetwork or sent as process data.

## 8.7.5. Store Transaction Templates

The transaction templates are stored on the **Transaction templates** page.

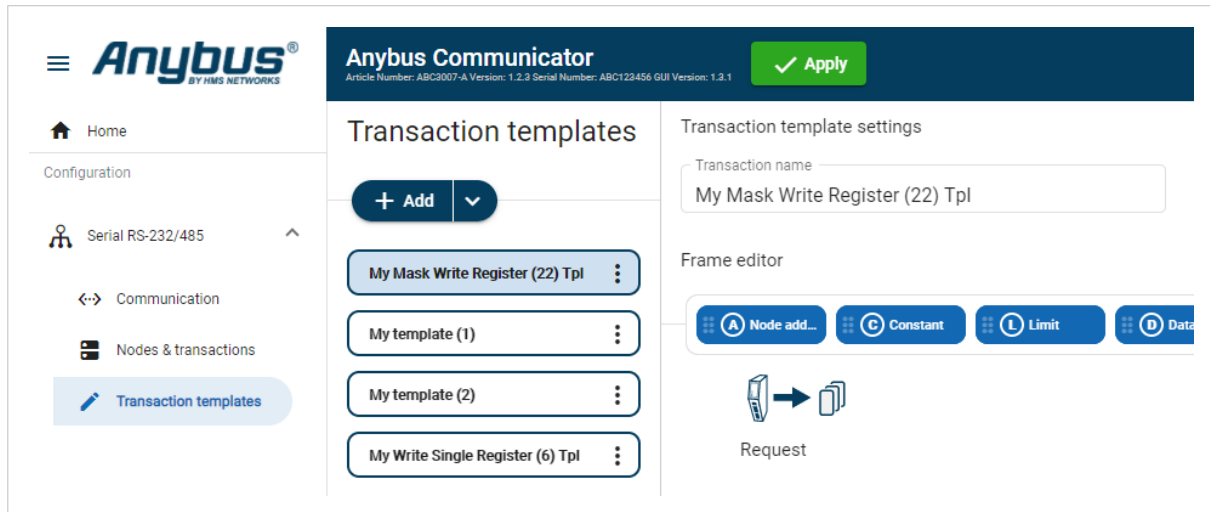

Figure 53. **Transaction templates** page

The transaction templates are available for use on the **Nodes & transaction** page, when you add transactions to a node.

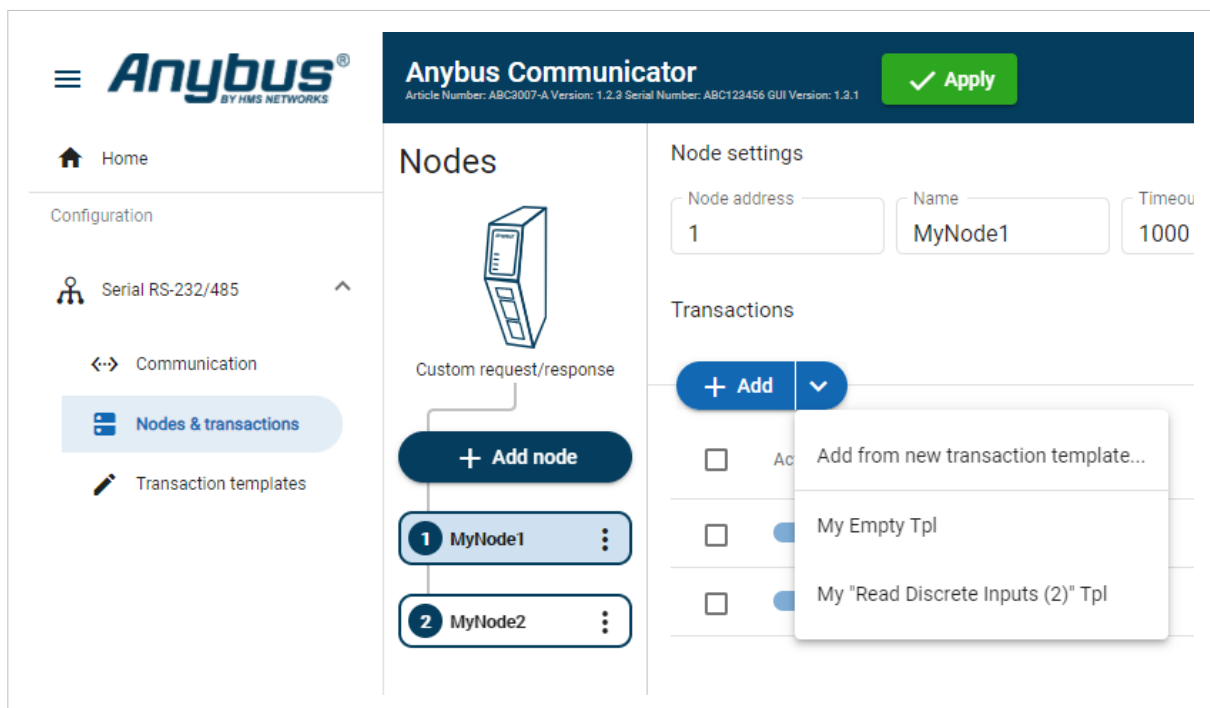

Figure 54. **Nodes & transaction** page

For information on how to add the transaction templates to the nodes, refer to [Transaction Settings \(page 89\)](#).

## 8.8. Nodes and Transactions

A node represents a single device on the serial subnetwork.

Add nodes and set up the communication between the nodes and the client.

### Before You Begin

Obtain user documentation, from the manufacturers of the devices to communicate with, describing available registers and how to address them.

#### 8.8.1. Node and Broadcast Node

You can add two types of nodes, Node and Broadcast Node.

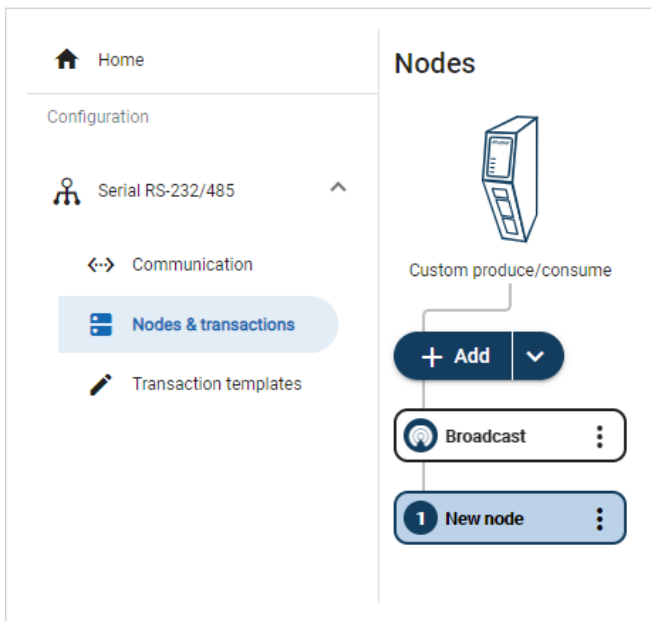

Figure 55. Add Node or Broadcast Node

#### Broadcast node

- You can add one single Broadcast node.
- The Broadcast node can only hold produce transactions.

#### Node

- You can add up to 31 Nodes.
- The type of transactions a node can hold depends on the serial protocol used, refer to [About Transaction Templates \(page 57\)](#).

## 8.8.2. Add Node



### NOTE

You can add one single Broadcast node.

The maximum number of Nodes that can be added is 31.

1. In the web-interface left sidebar menu, click **Nodes & transactions**.
2. In the **Add** split button drop-down menu, select **Add broadcast node** or **Add node**.  
To **Import node**, see [Import Node Settings From Other Communicator Unit \(page 78\)](#).

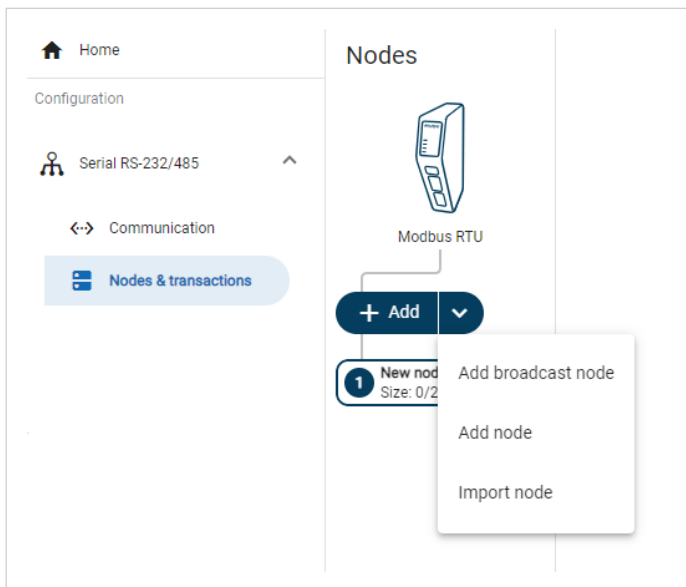

Figure 56. Add node

A new node/broadcast node is added to the nodes list.

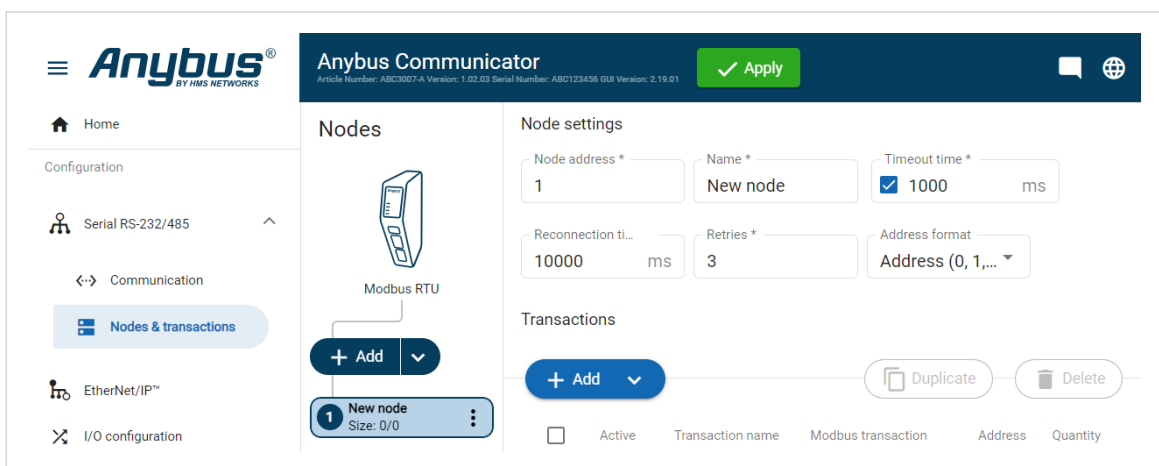

Figure 57. A new node is added to the node list

### To Do Next

Configure the Node Settings, [Node Settings \(page 85\)](#).

### 8.8.3. Import Node Settings From Other Communicator Unit

When you have configured a node and want to use the same node for additional Communicator units, do the following.

#### Procedure

##### To Export the Node

In the built-in web-interface of the Communicator with the node you want to export:

1. In the web-interface left sidebar menu, click **Nodes & transactions**.
2. On the node to be exported, click the three dots icon and then click **Export node**.  
A `.node` file including the node settings and the related transaction templates is downloaded to your computer.

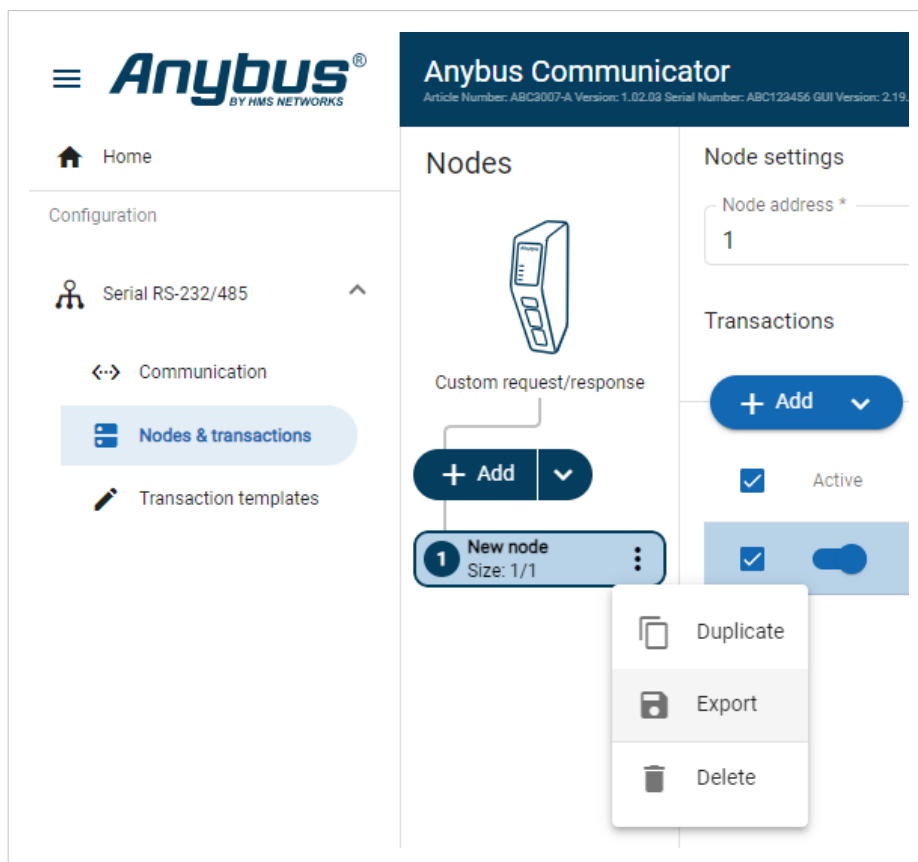

Figure 58. Export node

##### To Import the Node

In the built-in web-interface of the Communicator to which the node is to be imported:

3. In the web-interface left sidebar menu, click **Nodes & transactions**.

4. In the **Add** split button drop-down menu, select **Import node**.

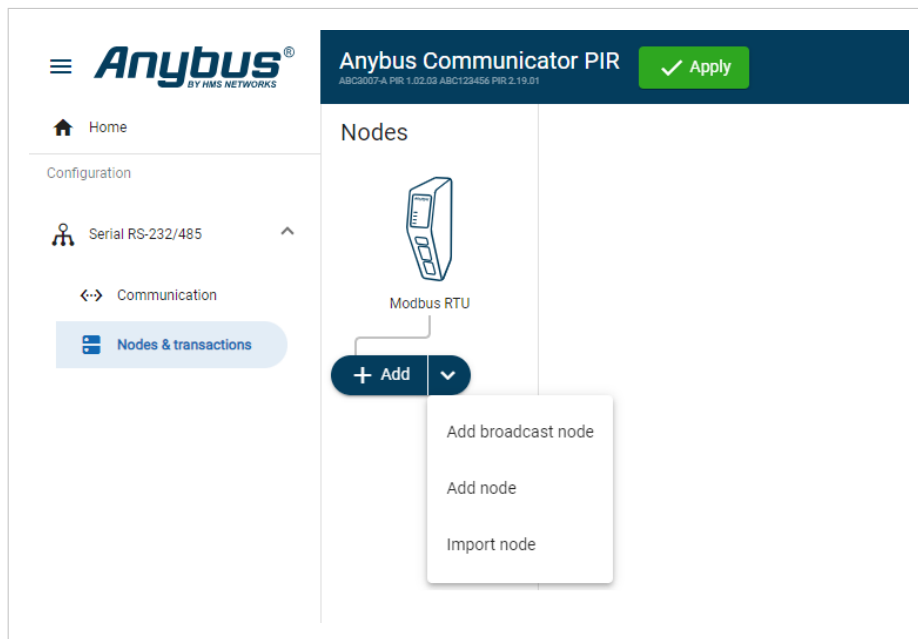

Figure 59. Import node

5. In the **Open** dialog box, browse to and select the `.node` file and click **Open**.
6. To import the `.node` file, click **Import**.

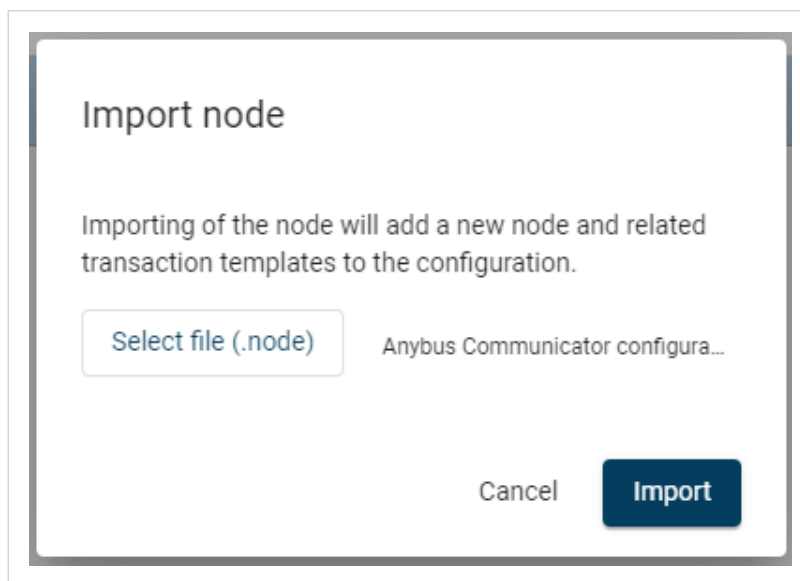

Figure 60. Example, selected .node file

**Result**

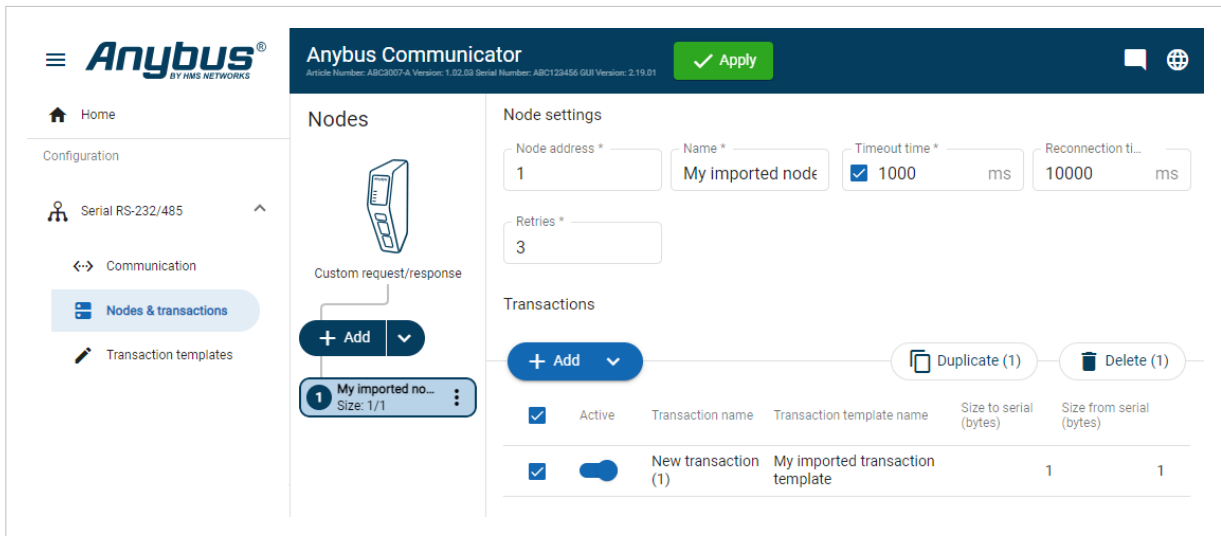

Figure 61. Example, imported node

The imported node is added to the **Nodes** list.

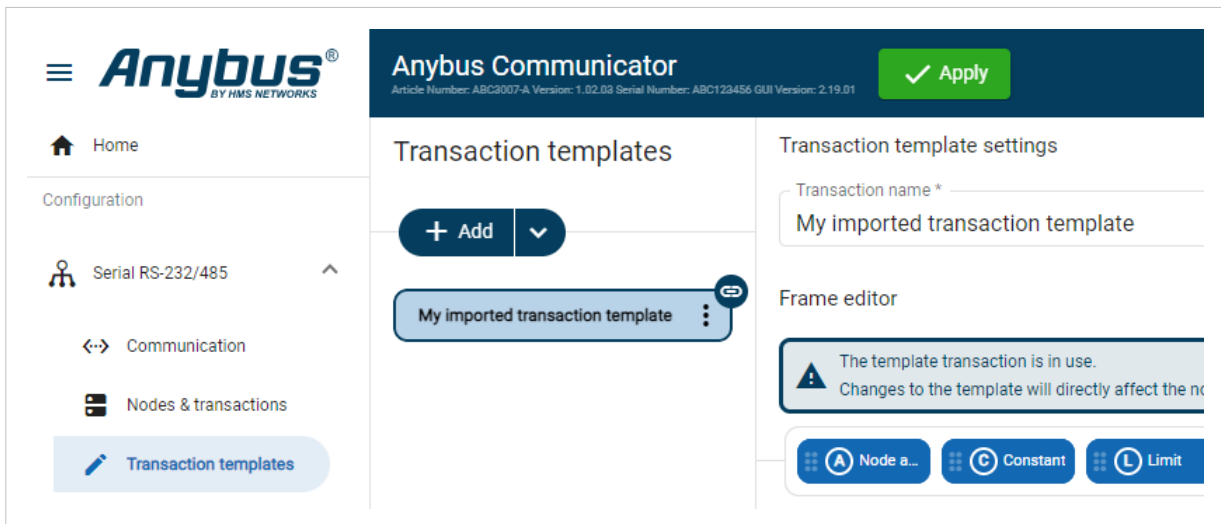

Figure 62. Example, imported transaction template

Any included transaction templates are added to the **Transaction templates** list on the **Transaction templates** page.

**To Do Next****IMPORTANT**

To identify the nodes and avoid node address conflicts on the subnetwork, each node (device) must have a unique node address number.

In the **Node settings** for the imported node, ensure that the **Node address** number is unique.

The screenshot shows the 'Anybus Communicator' web interface. The 'Nodes' section is active, displaying 'Node settings' for a node named 'My imported node'. The 'Node address' field is highlighted with a red box and contains the value '1'. Other settings include 'Name' (My imported node), 'Timeout time' (1000 ms), 'Reconnection time' (10000 ms), and 'Retries' (3). Below the node settings, there is a 'Transactions' section with a table of transactions.

Active	Transaction name	Transaction template name	Size to serial (bytes)	Size from serial (bytes)
<input checked="" type="checkbox"/>	New transaction (1)	My imported transaction template	1	1

Figure 63. Node settings, Node address number

To apply the settings, click **Apply** in the web-interface header, and follow the instructions.

### 8.8.4. Import Transaction Template From Other Communicator Unit

When you have configured a node and want to use the same node for additional Communicator units, do the following.

#### Procedure

##### To Export the Transaction Template

In the built-in web-interface of the Communicator with the transaction template you want to export:

1. In the web-interface left sidebar menu, click **Transaction templates**.
2. On the transaction template to be exported, click the three dots icon and then click **Export node**.  
A *.trans* file including the transaction template settings and frame fields is downloaded to your computer.

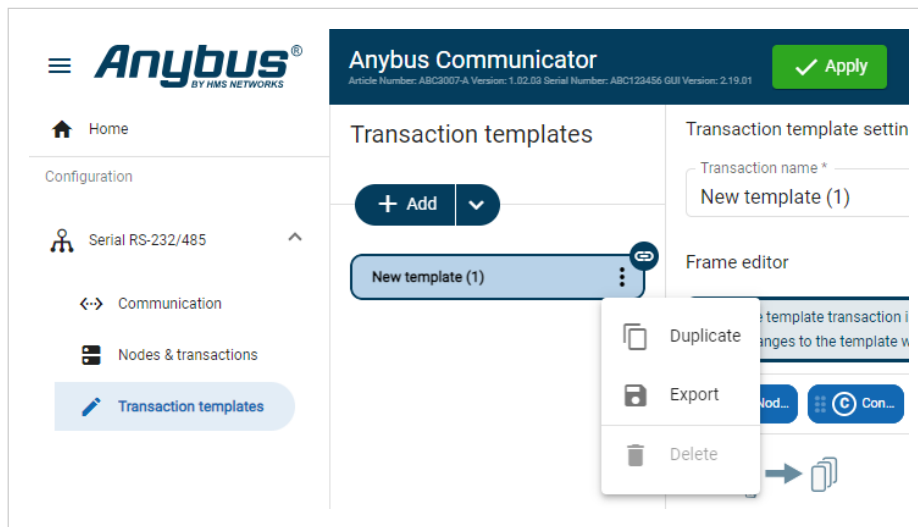

Figure 64. Export template

##### To Import the Transaction Template

In the built-in web-interface of the Communicator to which the transaction template is to be imported:

3. In the web-interface left sidebar menu, click **Transaction templates**.

4. In the **Add** split button drop-down menu, select **Import template**.

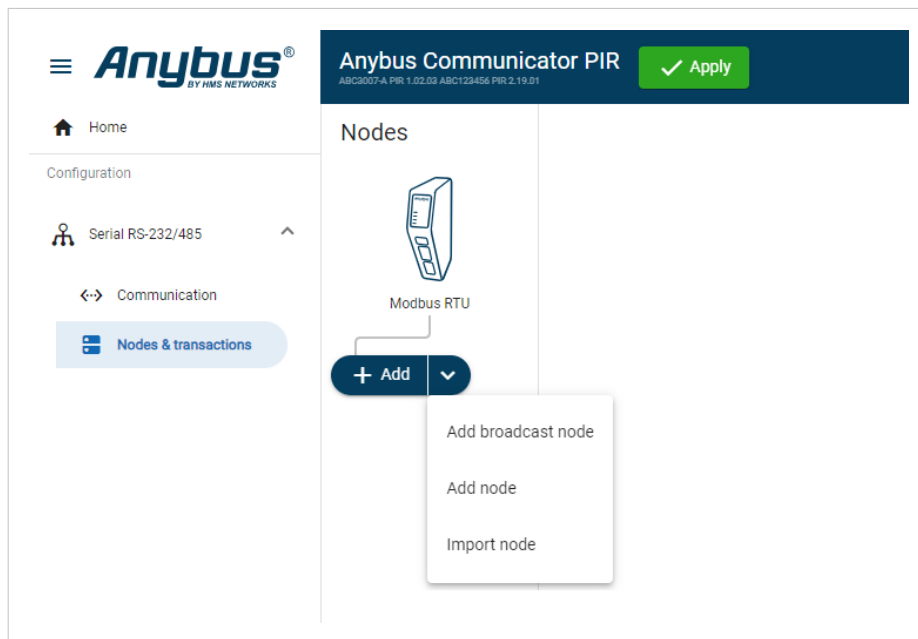

Figure 65. Import template

5. In the **Open** dialog box, browse to and select the `.trans` file and click **Open**.
6. To import the `.trans` file, click **Import**.

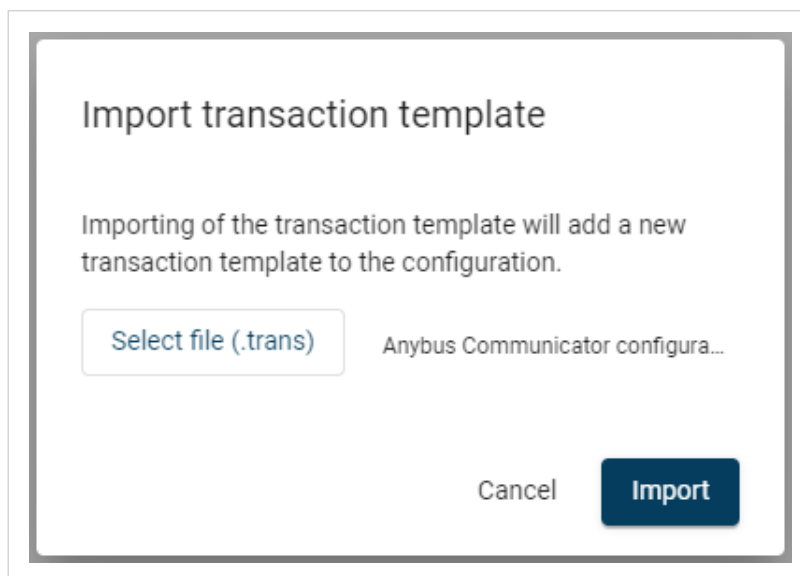

Figure 66. Example, selected .trans file

### Result

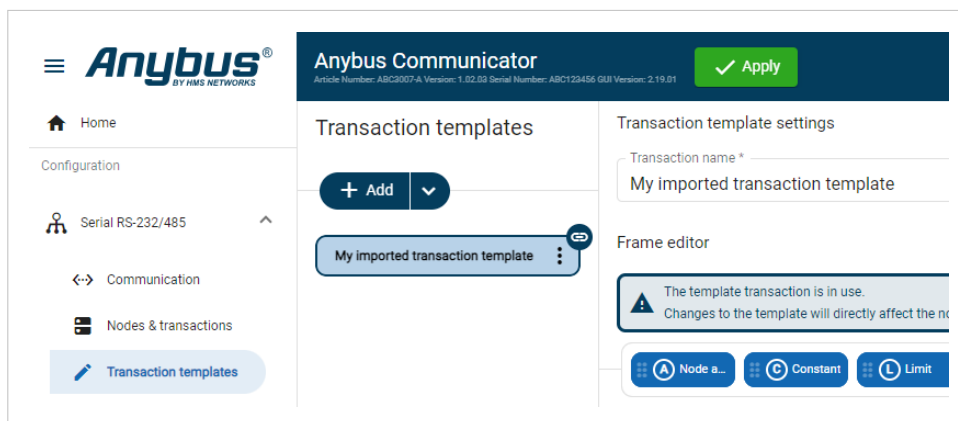

Figure 67. Example, imported transaction template

The imported transaction template is added to the **Transaction templates** list.

## 8.8.5. Node Settings

### Before You Begin

Ensure that the Communicator Basic settings, on the **Communication** page, match the Node settings.

There are no Node settings for the Broadcast node, except Name.

### Procedure

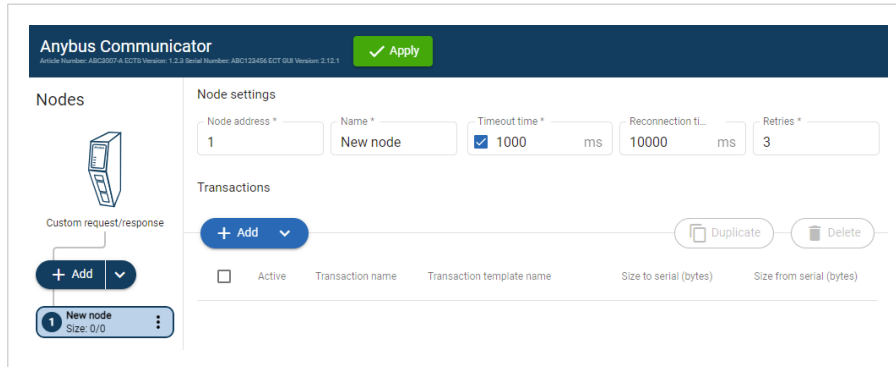

Figure 68. Nodes page, Node settings

1. In the node list, select a node to configure.
2. Configure the **Node settings**.

Setting	Value	Description
Node address	1 to 247	Node ID, also called node address, is the node's identity on the subnetwork. The node id is a number between 1 and 247. By default, the node is assigned the next available number. The same node id cannot be used on multiple nodes.
Name	N/A	By default, the node is assigned the name New node and the corresponding Server address. The node name can be changed.
Timeout time	10 ms to 10 000 ms Enabled by default Default 1000 ms	If a transaction in a transaction fulfills the specified timeout time value for all specified retries, the remaining transactions defined for the node will be skipped in the current cycle. The maximum addition to the cycle length is only one instance of the timeout setting. If enabled, specify how long the Communicator should wait before sending the message again, when no response is received from the node. If the timeout time is exceeded, the Communicator continues to send the message until the maximum number of retries has been reached. If disabled, the Communicator immediately sends the message again, when no response is received from the node
Reconnection time	Min 10 ms Max 60 0000 ms Default 10 000 ms	Specify for how long the Communicator should wait before attempting to reconnect, if the node is disconnected. Reconnect time (10 ms) is not applicable for the broadcast node, that hold transactions destined to all nodes.
Retries	0 to 10 Default 3	Specify the number of attempts the Communicator should make, when no response is received from the node.
Address format	Default format: Address Register Modicon Modicon extended	Available for the Modbus RTU serial protocol. Specify the address format for the node. Address: 0, 1, 2, ... Register: 1, 2, 3, ... Modicon: 00001/10001/30001/40001 Modicon extended: 000001/100001/...

3. To apply the settings, click **Apply** in the web-interface header, and follow the instructions.

### To Do Next

Add Transactions, [Add Transactions \(page 86\)](#).

### 8.8.6. Add Transactions



**NOTE**

The maximum number of transactions that can be added to a node is 150.

1. In the node list, select a node to configure.
2. In the transaction list, click **Add**.
3. Choose one of the following alternative:

**When using the Modbus RTU Serial Protocol**

- Click **Add** and select a transaction from the list of standard Modbus RTU transactions.

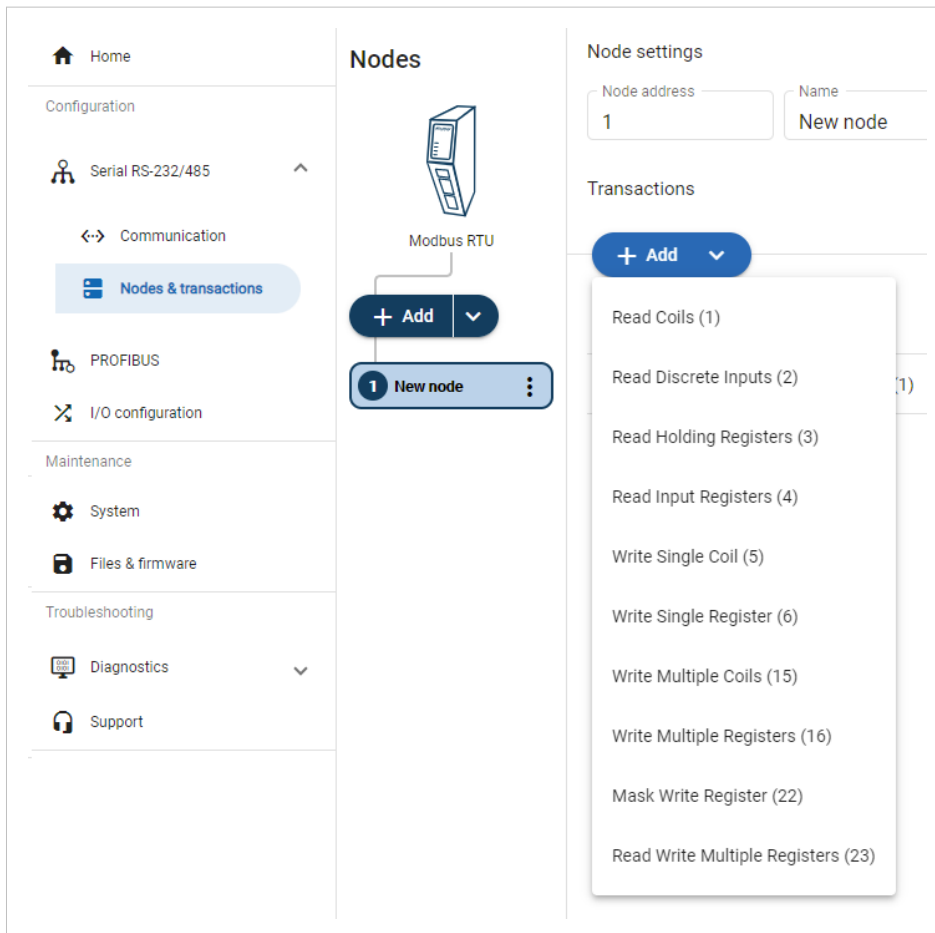

Figure 69. Add Modbus RTU transactions

## When using the Request/Response or Produce/Consume Serial Protocol

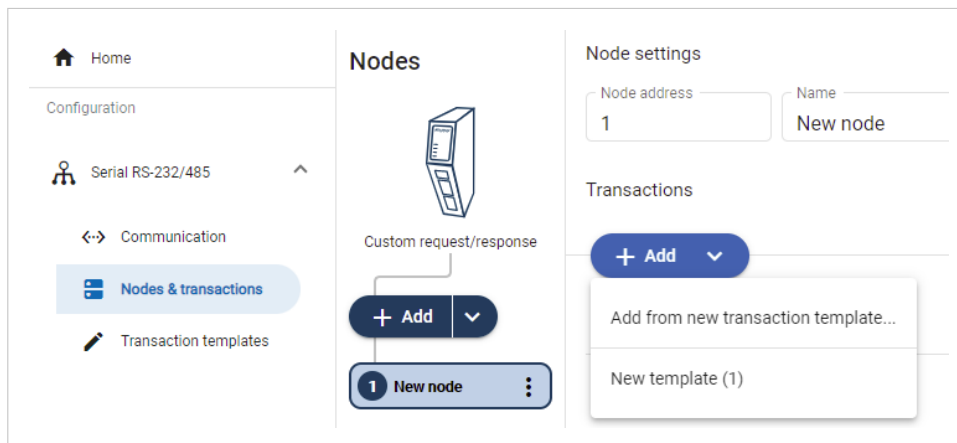

Figure 70. Add new empty template

- Click **Add** and select **Add from new transaction template**.  
You are redirected to the **Transaction template** page.  
A new empty template is added to the Transaction templates list.



### NOTE

You must build the transactions before you can use the template, refer to [Build Transaction Template \(page 63\)](#).

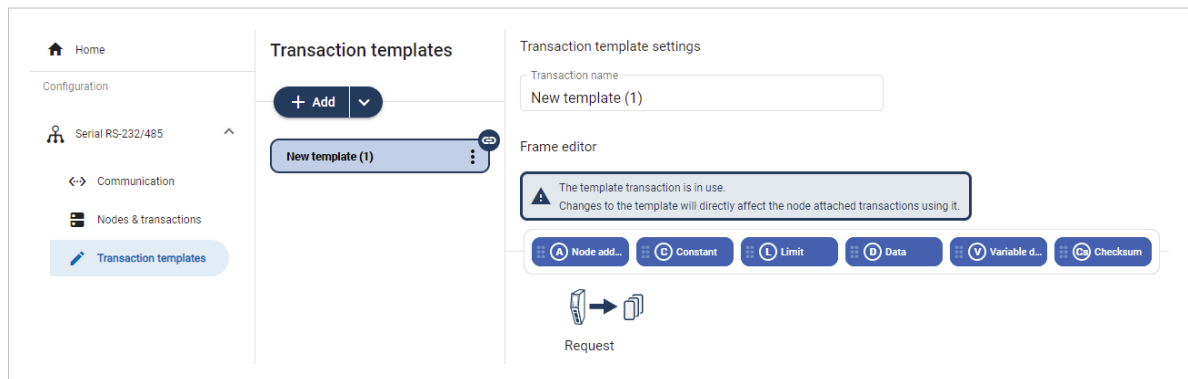

Figure 71. Add new empty template

- If you already have created Transaction templates, click **Add** and select the desired template from the list. A new transaction is added to the transactions list.

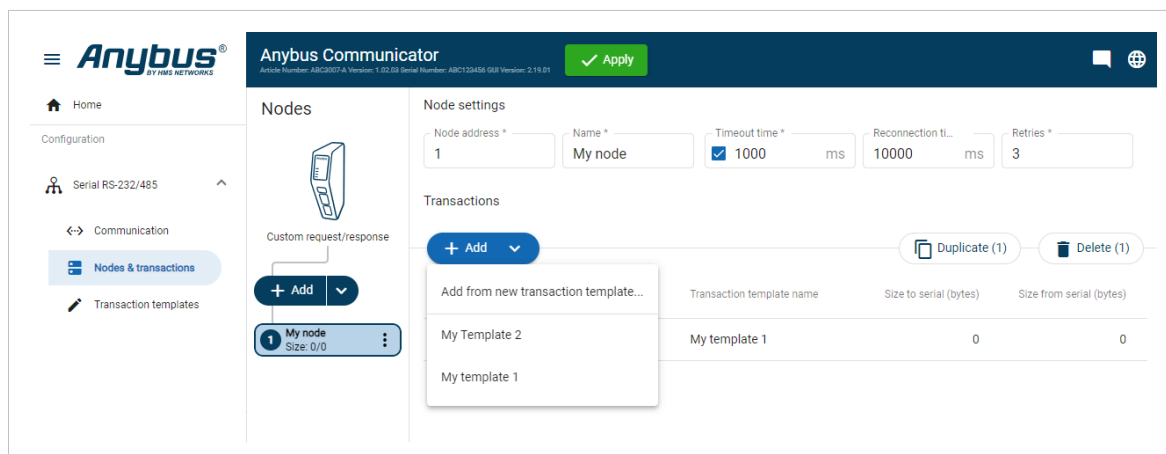

Figure 72. Add new transaction

**To Do Next**

Configure the Transactions settings, [Transaction Settings \(page 89\)](#).

## 8.8.7. Transaction Settings

### Before You Begin



#### NOTE

When a custom transaction is selected, the custom transaction template is locked for editing.

For Modbus transaction reference guide, refer to [Modbus Transactions \(page 161\)](#).

### Procedure

Figure 73. Modbus RTU serial protocol

Figure 74. Custom request/response protocol

1. In the node list, select a node to configure.
2. In the transactions list, select a transaction to configure.  
The transactions sidebar opens, on the right side of the screen.
3. Enter a transaction name.  
By default, the node is assigned the name New transaction.
4. Select a transaction type from the **Modbus transaction/Custom transaction** drop-down menu.  
The transaction type defines what the node should perform when the transaction is executed.

## 5. Configure the Command settings.

Setting	Value	Description
Transaction name	N/A	You can name the transaction to make it easier to identify.
Read quantity	1 to 125	Specifies the number of registers to read to follow in the read data field. Appear when Modbus transaction Read Write Multiple Registers (23) is selected.
Address	0 to 65 535	Specify the start address for the read/write transaction. The address acts as an address to the data position, where the data is read from or written to. Modbus holding register addresses starts at 0. Modbus address 0 = Register 1
Write quantity	Read Write Multiple Registers (23), 1 to 123	Specifies the quantity of registers to follow in the write data field. Appear when Modbus transaction Read Write Multiple Registers (23) is selected.
Quantity	Read Holding Registers (3) Read Input Registers (4), 1 to 125 Write Multiple Coils (15), 1 to 1968 Write Multiple Registers (16), 1 to 123 Read Coils (1) Read Discrete Inputs (2), 1 to 2000	The Quantity parameter appear when you select a Modbus transaction that can address more than one data object. Example when Quantity is set: For the Modbus Transaction Read Input Registers (4) you need to set the Quantity in order to define the array of data. Example when no Quantity is set: For the Modbus Transaction Write Single Coil (5) you do not need to set the Quantity parameter because there can not be an array of data. The transaction is used to write a single output to either ON or OFF in a remote device. For Write Single Coil (5), Write Single Register (6) and Mask Write Register (22) Quantity cannot be set.
Constant	0 to 255	The value of the Constant in the frame.
Data	0 to 512	The length of the data field.
Variable data	Byte counter: 0 to 255 End pattern: 0 to 1499 None (Default): 0 to 1500	The maximum payload length of the variable data field.
Update mode	Cyclically On data change Single shot Change of state on trigger	Specify when a transaction shall be sent to the server. The transaction is issued cyclically, at the interval specified in the Update time parameter. Cyclically: The transaction is sent cyclically, at the interval specified in the Update time parameter. On data change: The transaction is sent when the data is changed. Single shot: The transaction is issued once at start up. Change of state on trigger: The transaction is triggered when the content of a specified byte changes. In the <b>I/O configuration</b> , the node will be marked with a flash icon. In the <b>I/O configuration</b> you can also configure the area map and the trigger byte address. See <a href="#">Trigger Byte (page 102)</a> .
Update time	3 ms to 60 000 ms	Update mode parameter must be set to Cyclically. The Update time parameter appear when Cyclically is select. Specify how often, in steps of 10 ms, the transaction are going to be issued.
Positive ack	N/A	When Positive Acknowledgement is enabled, the positive ack data byte in the <b>I/O configuration</b> is incremented each time this transaction succeeds.
Negative ack	N/A	When Negative Acknowledgement is enabled, the negative ack data byte in the <b>I/O configuration</b> is incremented each time this transaction fails.

6. To apply the settings, click **Apply** in the web-interface header, and follow the instructions.

### 8.8.8. Activate/Deactivate Transaction

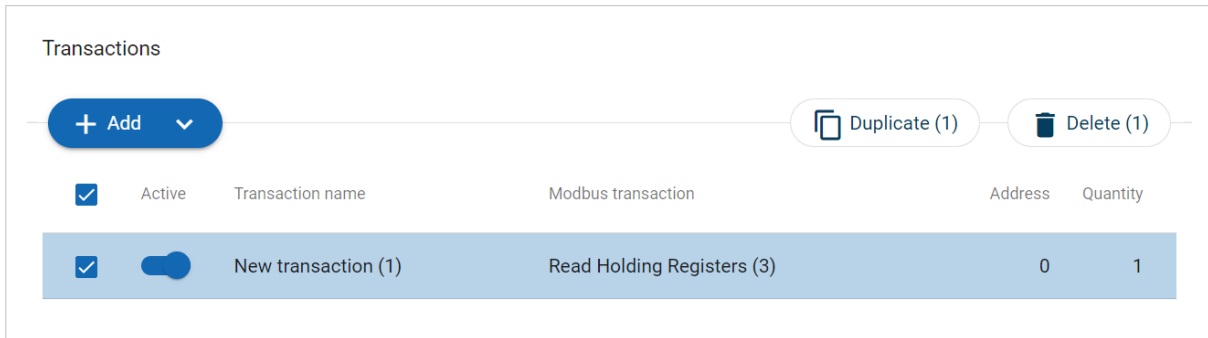

Figure 75. Activate/Deactivate Transaction

The transaction default status is **Active**.

To deactivate/activate a transaction, select the transaction and click the **slide toggle**.

### 8.8.9. Duplicate Transaction

When you duplicate a transaction, all settings are preserved.

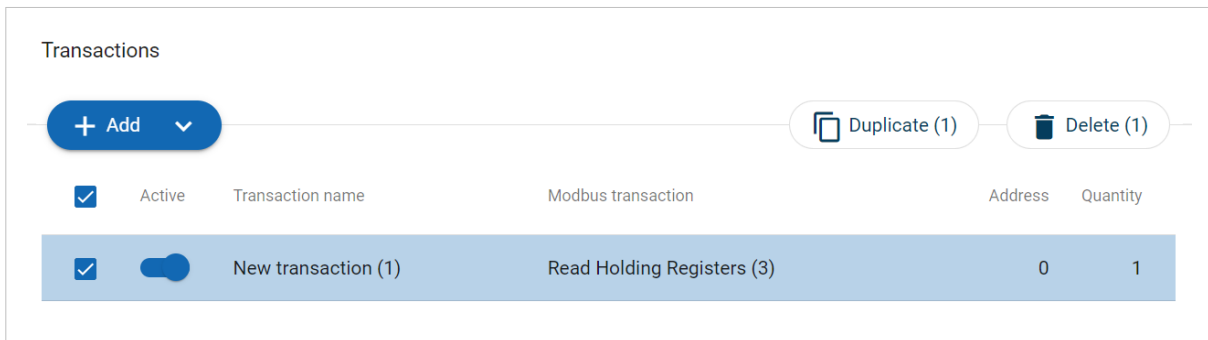

Figure 76. Duplicate transaction

To duplicate:

- One transaction, select the command and click **Duplicate**.
- Multiple transactions, select the checkbox in front of each transaction you want to duplicate and click **Duplicate**.

The duplicated transaction is added at the bottom of the transactions list.

## 8.8.10. Delete Transaction

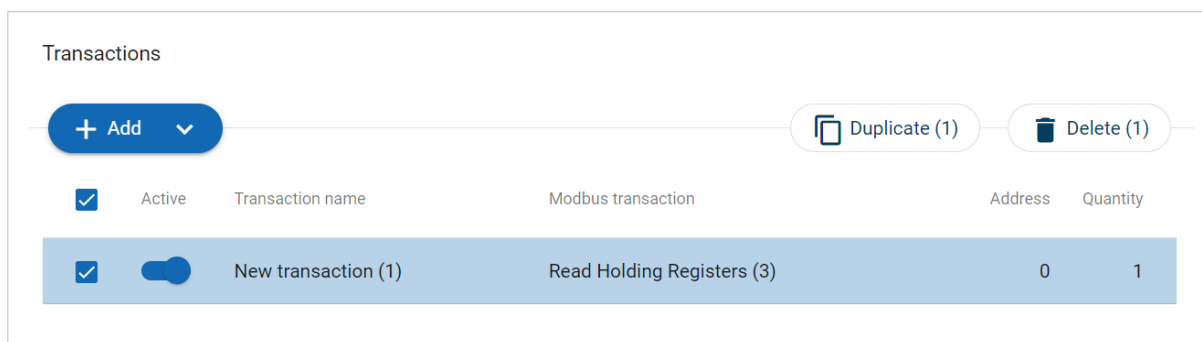

Figure 77. Delete transaction

1. To delete:
  - One transaction, select the transaction and click **Delete**.
  - Multiple transactions, select the checkbox in front of each transaction and click **Delete**.
2. To confirm, click **Yes**.

## 8.9. PROFIBUS Network Settings

Configure the PROFIBUS network settings.

### 8.9.1. To Use Automatic I/O Sizes

The screenshot shows the 'Anybus Communicator' header with version information and an 'Apply' button. Below is the 'PROFIBUS' section with 'I/O sizes' sub-section. A checkbox labeled 'Use automatic I/O sizes' is checked. A note states: 'When "Use automatic I/O sizes" is checked the size of the I/O data to and from the OT network will be set to the same size as provided by the serial subnetwork.' Two input fields are present: 'Data size to EtherNet/IP™' with the value '2' and 'Data size from EtherNet/IP™' with the value '0'.

Figure 78. PROFIBUS, I/O sizes

By default, the Communicator is set to use automatic I/O sizes.

The size of the input data, Data Size to PROFIBUS, and the output data, Data Size from PROFIBUS, is determined by the subnetwork configuration.

In the Communicator built-in web interface, the **Use Automatic I/O Sizes** checkbox is selected.

### 8.9.2. To Configure I/O Sizes Manually

 **NOTE**  
The maximum data size in each direction is 244 bytes bytes.

The screenshot shows the 'Anybus Communicator' header with version information and a green 'Apply' button. Below is the 'PROFIBUS' section with 'I/O sizes' sub-section. A checkbox labeled 'Use automatic I/O sizes' is deselected. A note states: 'When "Use automatic I/O sizes" is checked the size of the I/O data to and from the OT network will be set to the same size as provided by the serial subnetwork.' Two input fields are present: 'Data size to EtherNet/IP™' with the value '2' and 'Data size from EtherNet/IP™' with the value '0'.

Figure 79. PROFIBUS, I/O sizes

1. Deselect the **Use Automatic I/O Sizes** checkbox.
2. Enter a value for Data Size to PROFIBUS and a value for Data Size from PROFIBUS.

### 8.9.3. I/O Size Restrictions for Allow Any Module Mapping

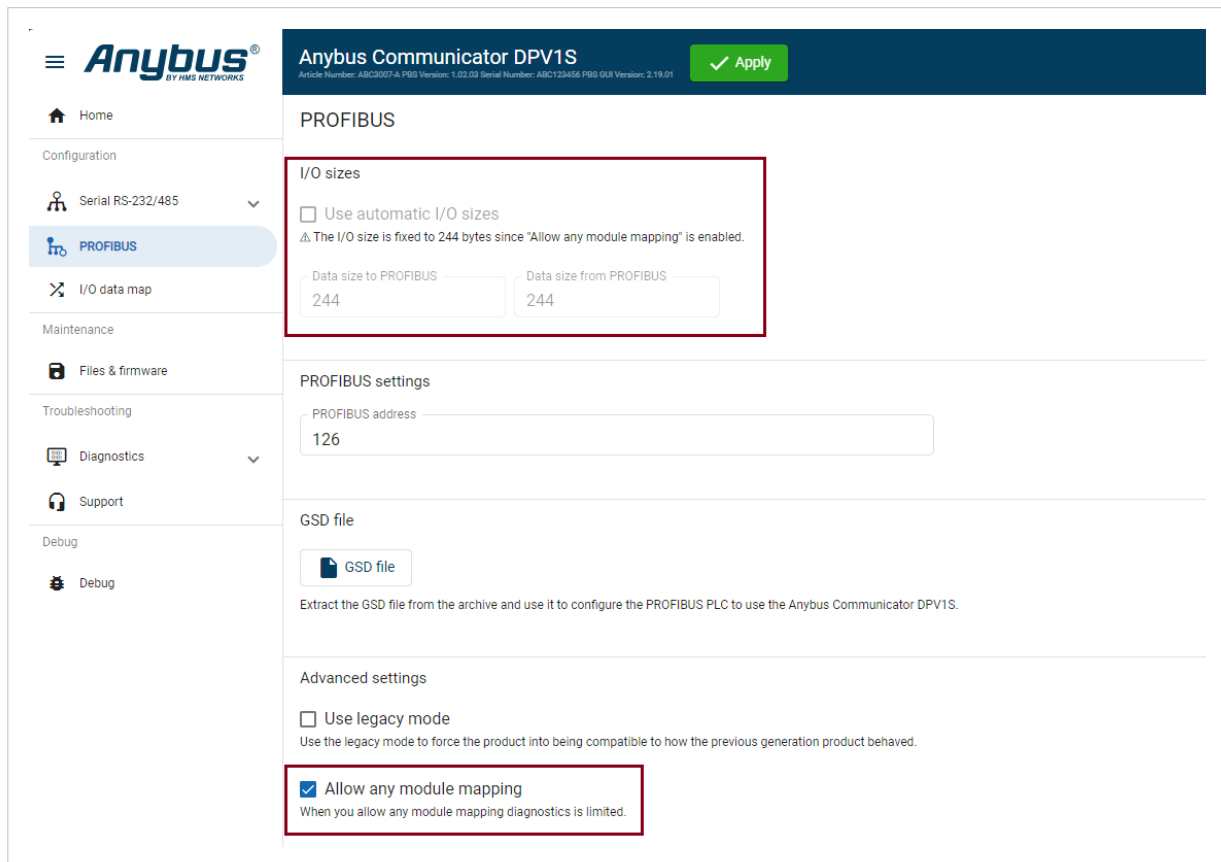

The screenshot shows the configuration interface for Anybus Communicator DPV1S. The left sidebar contains navigation options: Home, Configuration (Serial RS-232/485, PROFIBUS, I/O data map), Maintenance (Files & firmware), Troubleshooting (Diagnostics, Support), and Debug (Debug). The main content area is titled 'PROFIBUS' and includes an 'Apply' button. The 'I/O sizes' section is highlighted with a red box and contains the following text: 'I/O sizes', 'Use automatic I/O sizes' (unchecked), and a warning: '⚠ The I/O size is fixed to 244 bytes since "Allow any module mapping" is enabled.' Below this are two input fields for 'Data size to PROFIBUS' and 'Data size from PROFIBUS', both containing the value '244'. The 'PROFIBUS settings' section shows 'PROFIBUS address' set to '126'. The 'GSD file' section has a 'GSD file' button and a note: 'Extract the GSD file from the archive and use it to configure the PROFIBUS PLC to use the Anybus Communicator DPV1S.' The 'Advanced settings' section includes 'Use legacy mode' (unchecked) and 'Allow any module mapping' (checked), with a note: 'When you allow any module mapping diagnostics is limited.' This 'Allow any module mapping' option is also highlighted with a red box.

Figure 80. PROFIBUS page, I/O sizes

When Allow any module mapping is enabled, the **I/O sizes** settings on the **PROFIBUS** page are disabled.

The **I/O sizes** settings are grayed out and cannot be changed.



#### NOTE

The data size values shown in the interface are only placeholders and are not used. The Communicator will adapt the I/O size according to how the modules are configured in the PLC.

See [Allow Any Module Mapping \(page 97\)](#).

### 8.9.4. PROFIBUS Address Settings

 **NOTE**  
Ensure that the Communicator rotary switches are set to 000.

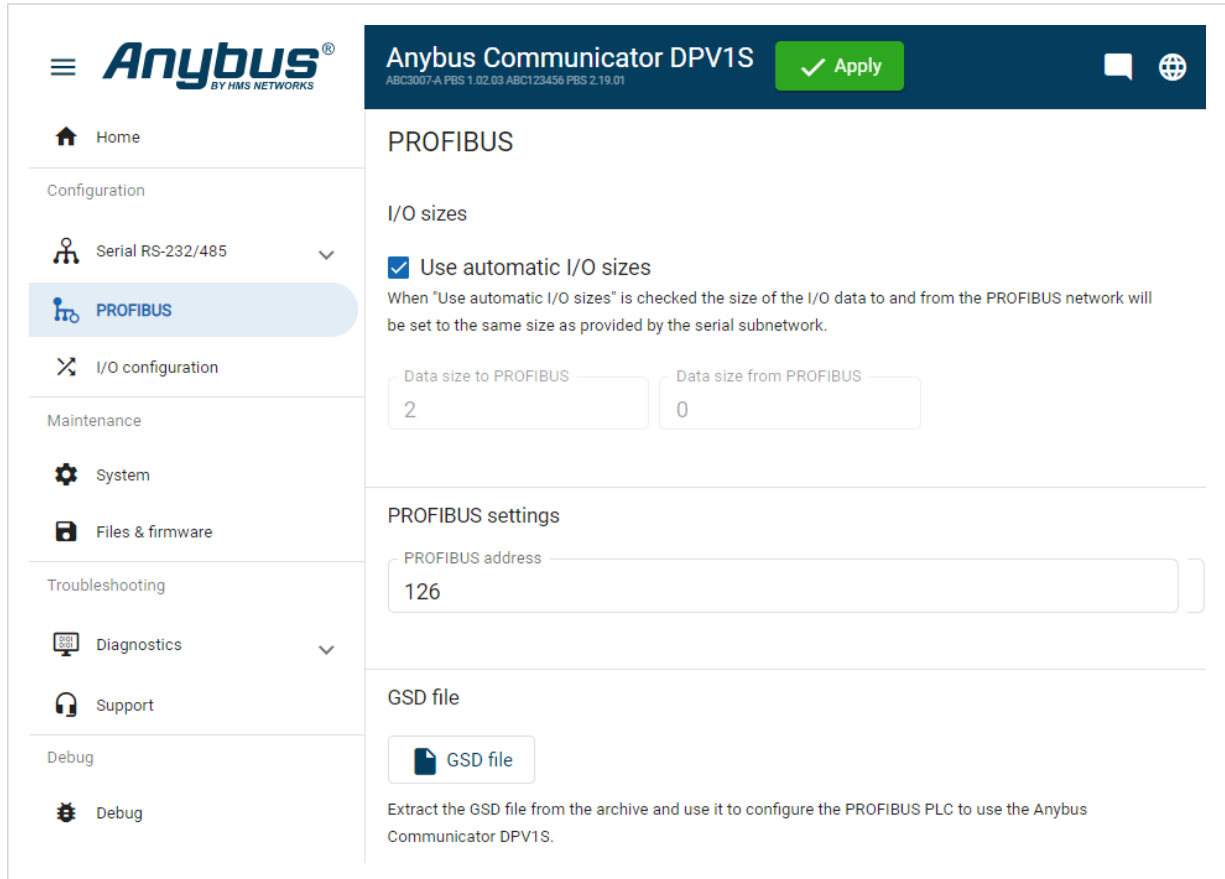

The screenshot shows the Anybus Communicator DPV1S web interface. The top navigation bar includes the Anybus logo, the device name 'Anybus Communicator DPV1S', and an 'Apply' button. The left sidebar contains a menu with categories: Home, Configuration (Serial RS-232/485, PROFIBUS, I/O configuration), Maintenance (System, Files & firmware), Troubleshooting (Diagnostics, Support), and Debug (Debug). The main content area is titled 'PROFIBUS' and contains the following sections:

- I/O sizes:** A checkbox for 'Use automatic I/O sizes' is checked. Below it, a text box explains: 'When "Use automatic I/O sizes" is checked the size of the I/O data to and from the PROFIBUS network will be set to the same size as provided by the serial subnetwork.' There are two input fields: 'Data size to PROFIBUS' with the value '2' and 'Data size from PROFIBUS' with the value '0'.
- PROFIBUS settings:** A text input field for 'PROFIBUS address' contains the value '126'.
- GSD file:** A button labeled 'GSD file' is present. Below it, a text box states: 'Extract the GSD file from the archive and use it to configure the PROFIBUS PLC to use the Anybus Communicator DPV1S.'

Figure 81. PROFIBUS address setting

In the PROFIBUS address field, enter the Communicator node address.

## 8.10. PROFIBUS Advanced Settings

### 8.10.1. Legacy Mode

**Advanced settings** option for PROFIBUS.

#### Before You Begin

If you already have an GSD (General Station Description) file installed in your PLC, legacy mode allows you to continue using the settings from the GSD file for the new Communicator.



#### IMPORTANT

Legacy mode does not support acyclic communication.

#### Compatible Product Variants GSD Files

The GSD file for AB7000 Anybus Communicator PROFIBUS is compatible with the new Communicator.

#### Procedure



#### NOTE

When Use legacy mode is enabled, **Allow any module mapping** is automatically enabled. When **Allow any module mapping** is enabled, the **Diagnostics** functionality is limited.

GSD file

GSD file

Not applicable in Legacy mode. Uses the already installed ABX Classic GSD file.

Advanced settings

Use legacy mode  
Use the legacy mode to force the product into being compatible to how the previous generation product behaved.

Allow any module mapping  
When you allow any module mapping diagnostics is limited.

Figure 82. Advanced settings > Use legacy mode

To enable the legacy mode, select the **Use legacy mode** checkbox.

When Use legacy mode is enabled, the **GSD file** download becomes inactive.

## 8.10.2. Allow Any Module Mapping

Advanced settings option for PROFIBUS.

### Before You Begin



#### NOTE

When Allow any module mapping is enabled, the **Diagnostics** functionality is limited.



#### NOTE

When Allow any module mapping is enabled, the **PROFIBUS** setting **I/O sizes** is restricted.

For more information, see [I/O Size Restrictions for Allow Any Module Mapping \(page 94\)](#).

**Allow any module mapping** has fewer restrictions and allows the modules to be mapped in any slot.

### Option 1 - Use Legacy Mode and Allow any Module Mapping Enabled

#### Procedure

GSD file

GSD file

Not applicable in Legacy mode. Uses the already installed ABX Classic GSD file.

Advanced settings

Use legacy mode  
Use the legacy mode to force the product into being compatible to how the previous generation product behaved.

Allow any module mapping  
When you allow any module mapping diagnostics is limited.

Figure 83. Advanced settings, **Use legacy mode** and **Allow any module mapping** is enabled

When **Use legacy mode** is enabled **Allow any module mapping** is automatically enabled.

## Option 2 - Allow Any Module Mapping Enabled

### GSD File Compatible With Allow Any Module Mapping



#### NOTE

When the *HMSB183B.gsd* file is used, the Communicator cannot provide diagnosis data. The **Diagnostics** functionality becomes inactive.

When only the **Allow any Module Mapping** is enabled, use the Communicator GSD file named *HMSB183B.gsd* to configure the PLC connected to the Communicator.

The *HMSB183B.gsd* file:

- Contains no slot definitions.
- Allows the modules to be plugged into any slot.
- Allows the same type of module to be used multiple times.

See also [Export Product GSD File \(page 116\)](#).

### Procedure

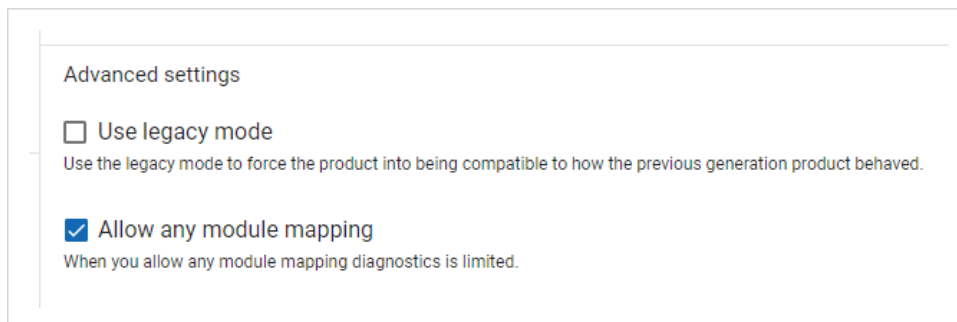

Figure 84. Advanced settings, **Allow any Module Mapping** is enabled

To enable any module mapping, select the **Allow any module mapping** checkbox.

## 8.11. I/O Configuration

The screenshot shows the 'I/O configuration' page in the Anybus Communicator ECTS interface. The page is divided into two main sections: 'Data from EtherCAT' and 'Data to EtherCAT'. Each section has a 'Data exchange control' toggle (currently off) and a 'Live list' toggle (currently on). Below these are tables mapping address ranges to node names and register types.

Address	Node
0 ... 1	My Machine Read Coils
2 ... 5	My Machine Read Write Multiple Registers
6 ... 9	My Machine Read Holding Registers
10 ... 1499	

Address	Node
0 ... 1	My Machine Write Multiple Coils
2 ... 11	My Machine Read Write Multiple Registers
12 ... 1499	

Figure 85. I/O configuration page

On the **I/O configuration** page the data communication between the subnetwork (Node) and the high level network (PLC) is mapped.

The allocated I/O area is auto-generated based on how the settings on the **Serial communication** page and the **Nodes and transactions** page are configured.

It is possible to set the I/O area manually, if you want to pro-actively allocate more I/O for future expansions without re-configuring the PLC. See [To Configure I/O Sizes Manually \(page 93\)](#).

There are three areas: **Data from PROFIBUS**, **Data to PROFIBUS** and **General area**. See [Map Area \(page 102\)](#).

### 8.11.1. Optimize the I/O Configuration

The optimize function is used to automatically remove gaps between the mapping.



#### IMPORTANT

Optimize remove gaps between the data objects in the map and should be used with care on already commissioned systems. Expected mapping in the PLC may change.



#### NOTE

If you optimize the I/O configuration, the current I/O configuration will be overwritten.

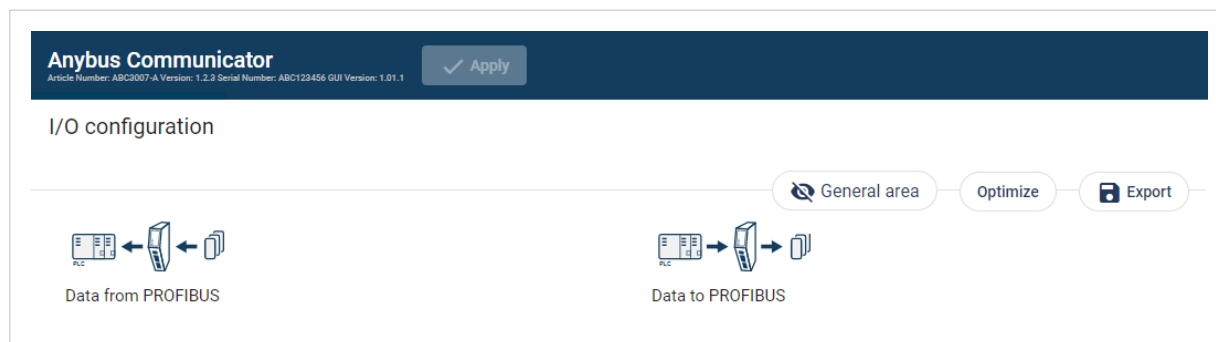

Figure 86. I/O configuration page, Optimize

To optimize the map:

1. Click **Optimize**.
2. To confirm, click **OK**.

### 8.11.2. Map Area Transactions Order

To change the order of the transactions in a map area, drag and drop the desired transaction to a new location.

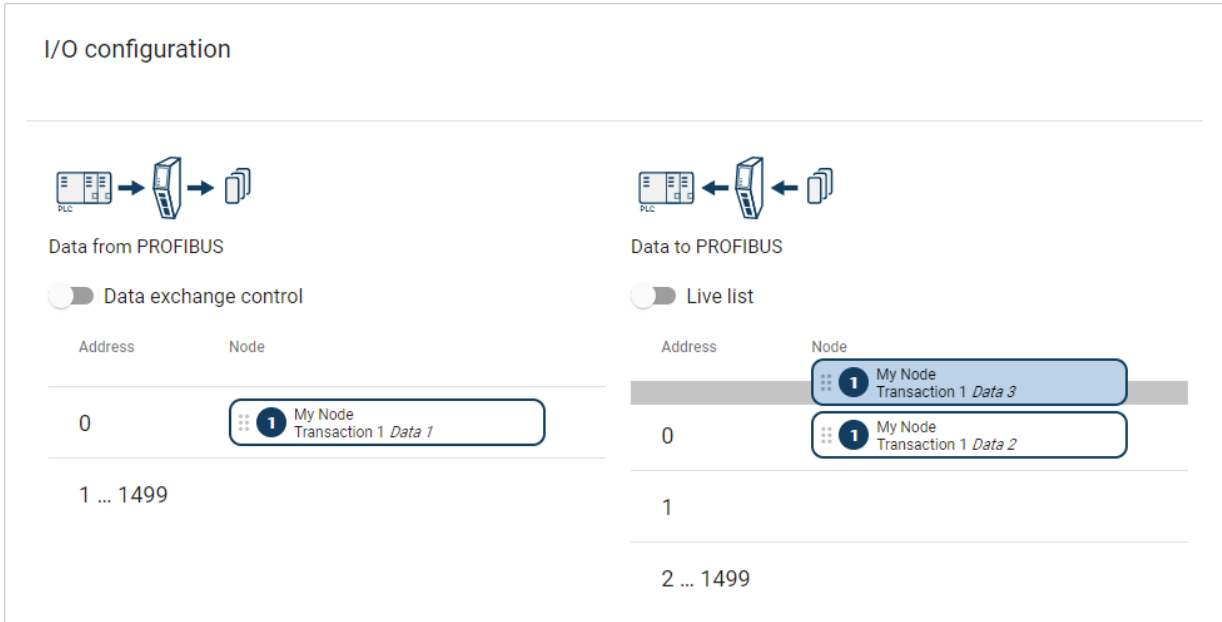

Figure 87. I/O configuration page, change the order of transactions

Transactions can not share the same I/O area.

If multiple transactions are placed in the same I/O area, the area is highlighted.

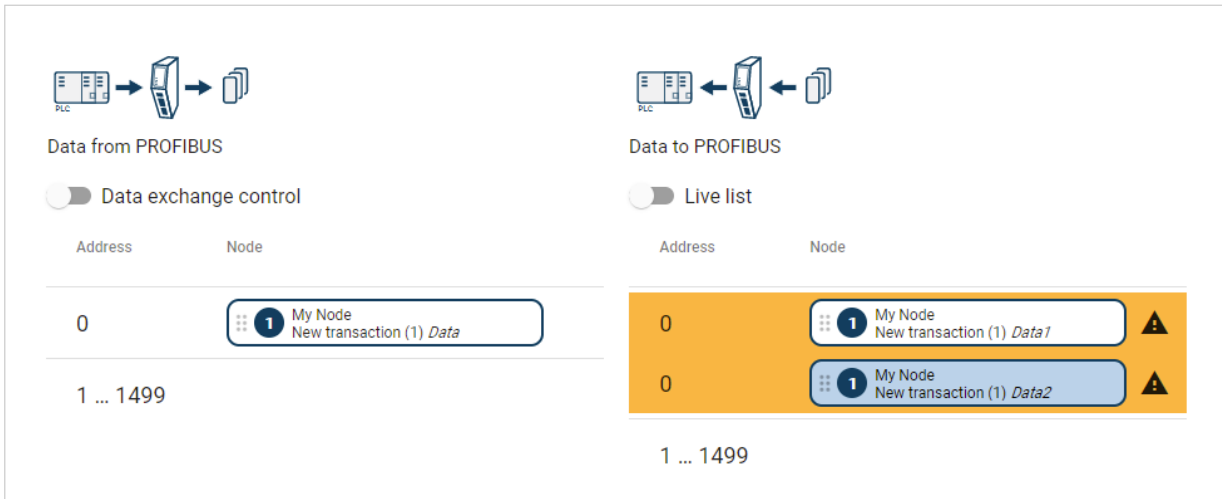

Figure 88. Highlighted I/O area

### 8.11.3. Map Area



Figure 89. I/O configuration page, Map area options

#### Map area options

You must specify the map area to use for each transaction in the I/O configuration.

Select one of the following **Map area** options:

- **Input/Output:** The transaction data is sent/recieved to/from the high level network.
- **General:** This area is used for transferring transaction data between individual nodes on the subnetwork. When General is selected, the transaction data cannot be accessed from the high level network.
- **Unmapped:** The transaction data is not used.

#### Start address

For Input/Output and General, you can enter a start address for the transaction data.

### 8.11.4. Trigger Byte

Trigger byte is used to enable/disable the trigger functionality for the response.

When Trigger byte is enabled, the Communicator increases the trigger byte by one when the Communicator receives new data from the subnetwork.

The Trigger byte is stored in the **Data from PROFIBUS** area or the **General** area.

The location of the trigger byte is specified by the address.

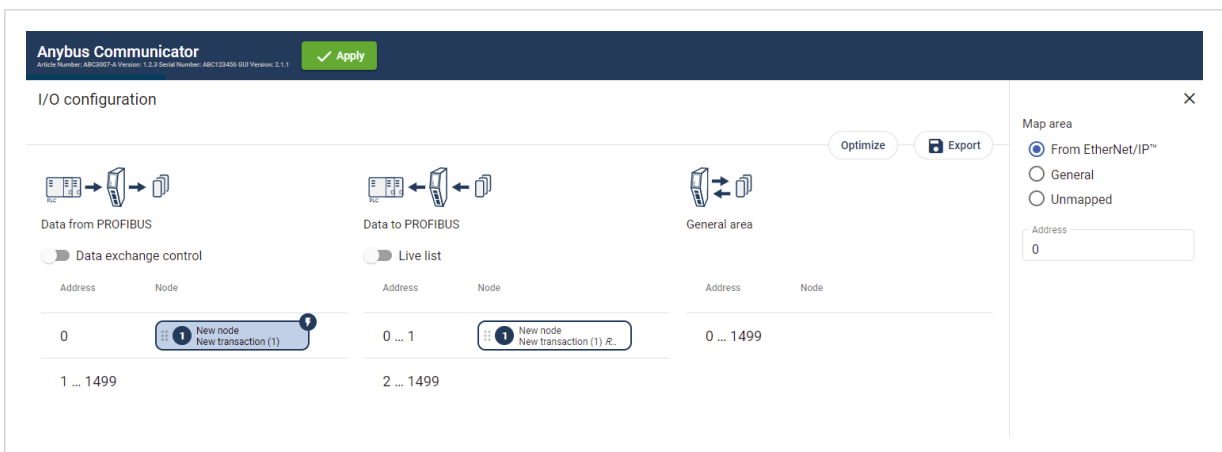

Figure 90. I/O configuration page

## How to Enable Trigger Byte on a Node

### Procedure

1. Navigate to the **Nodes & transactions** page.
2. Select the decried node and transaction.
3. In the transaction sidebar **Update mode** menu, select **Change of state on trigger**.
4. Navigate to the **I/O configuration** page.
5. The transaction with the trigger byte enabled is marked with a flash icon.  
To open the **Map area** sidebar, click on the flash icon.
6. In the **Map area** sidebar, specify the map area to use and the trigger byte address:

#### Map area options

- **From PROFIBUS:** The trigger byte is stored in the I/O configuration **Data from PROFIBUS** area.
- **General:** The trigger byte is stored in the I/O configuration **General area**.
- **Unmapped:** The transaction data is not used.

#### Address

- Enter an Address, the location in the specified Map area (From PROFIBUS or General) where the trigger byte will be saved.  
Value: 0 (default) to 1499

## 8.11.5. Endian Swap

By default PROFIBUS uses the big-endian format.

### About Endianness

#### Big-endian (BE)

The big-endian format places the most significant byte of the data at the byte with the lowest memory address.

#### Little-endian (LE)

The little-endian format places the least significant byte of the data at the byte with the lowest memory address.

### Convert Between Big-Endian and Little-Endian

To convert between big-endian and little-endian you must reverse the byte order.

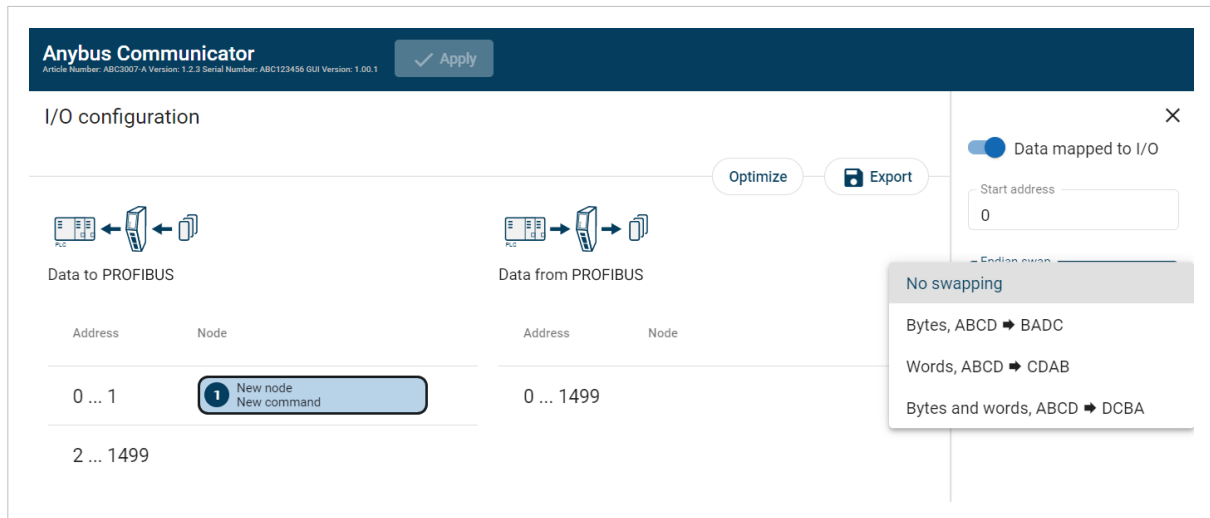

Figure 91. I/O configuration page, Endian swap

To reverse the byte order:

1. In the web-interface left sidebar menu, click **I/O configuration**.
2. In the data map, select the transaction for which you want to do swap the byte order.
3. Select the endian swap type from the **Endian swap** drop-down menu.

Setting	Description
No swapping	Default setting No swapping is performed on the data.
Bytes	Swap 2 bytes A B C D becomes B A D C
Words	Swap 4 bytes A B C D becomes C D A B
Bytes and words	A B C D becomes D C B A

4. To apply the settings, click **Apply** in the web-interface header, and follow the instructions.

### 8.11.6. Offline Option

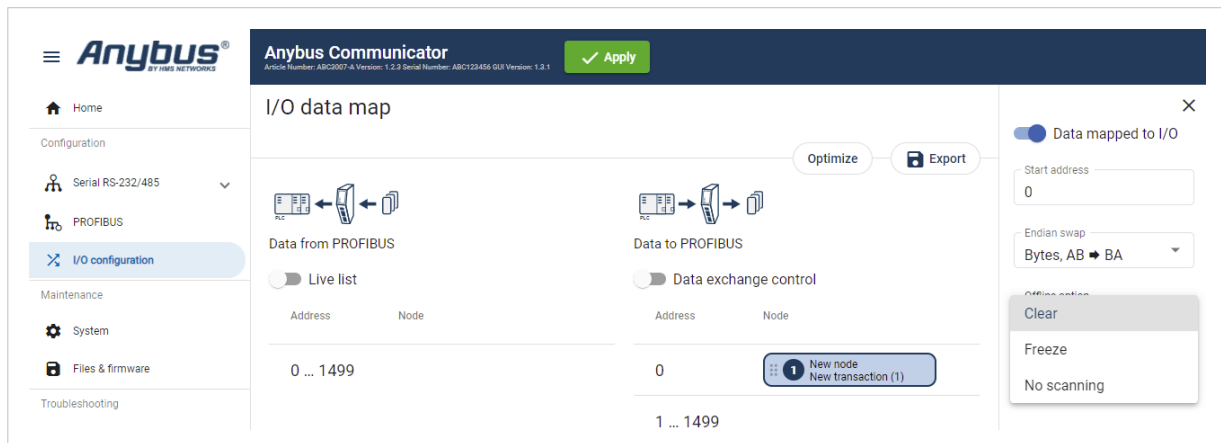

Figure 92. I/O configuration page, Offline options

Offline mode is used to define what data to send if the network connection or connection with a specific node is lost.

You must specify the offline mode to use for each transaction in the I/O configuration.

Select one of the following **Offline options**:

- **Clear (Default)**: The data is cleared and the value 0 is sent.
- **Freeze**: The Communicator holds the value until the connection is restored.
- **No scanning**: Stop sending this transaction on the sub-network. This option is only valid for produce and request transactions.

### 8.11.7. Live List

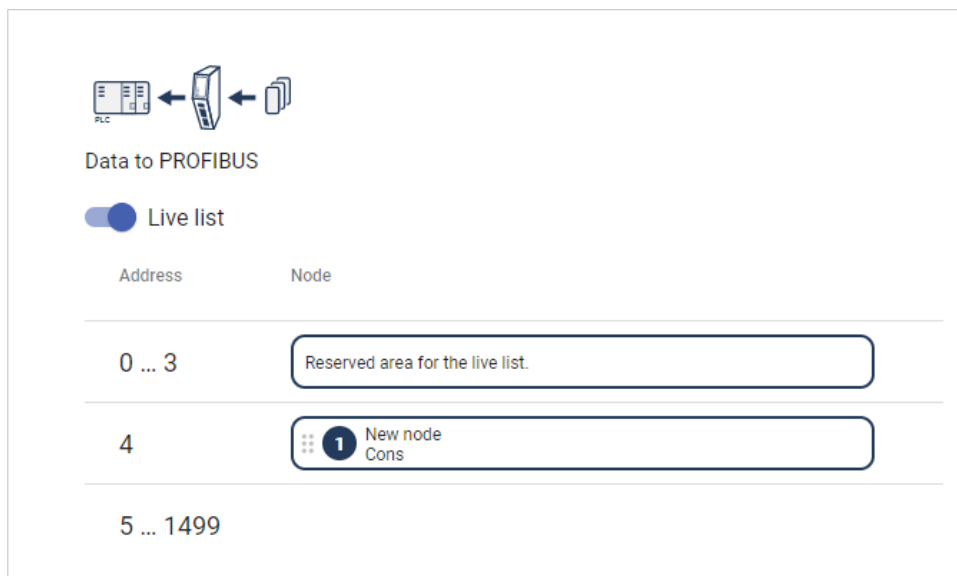

Figure 93. I/O configuration page, Live list enabled

By default, **Live list** is disabled.

#### About the Live List

- When **Live list** is enabled, the first four bytes of process data on the PROFIBUS network contain the live list.
- Each bit in the **Live list** can hold the status for one node.
- The **Live list** holds 32 bits, a total of 32 nodes connected to the Communicator.
- The bit is 0 when the bit does not correspond to a configured node.  
For example, this occurs when the number of configured nodes is less than 32.
- Each bit is 1 when the corresponding nodes is online.

### 8.11.8. Data Exchange Control

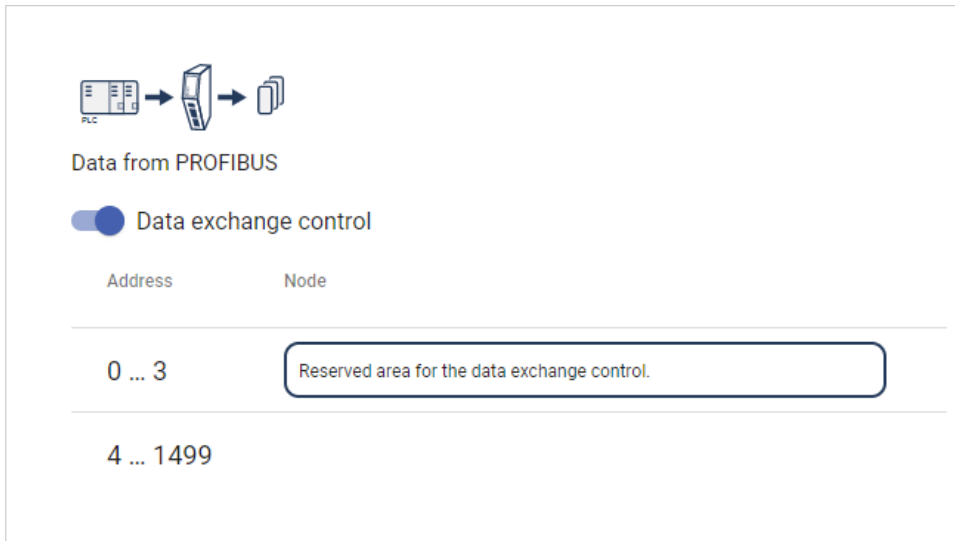

Figure 94. I/O configuration, **Data exchange control** enabled

By default **Data exchange control** is disabled.

When **Data exchange control** is enabled, the first four bytes of process data on the PROFIBUS network contain the data exchange control.

The **Data exchange control** holds 32 bits.

Each bit in the **Data exchange control** can be used to enable/disable data exchange for individual node on the subnetwork.

If control bit does not correspond to a configured node, the control bit is ignored. For example, this occurs when the number of configured nodes is less than 32.

The node order in the **Data exchange control** 32 bit array always matches the Live List.

When data exchange is enabled for the corresponding node, the control bit is 1.

## 8.12. Configuration Notes

You can add notes to describe the Communicator configuration.

### 8.12.1. Add Configuration Note

#### Procedure

1. To open the **Configuration Notes** window, click on the **comments** icon .

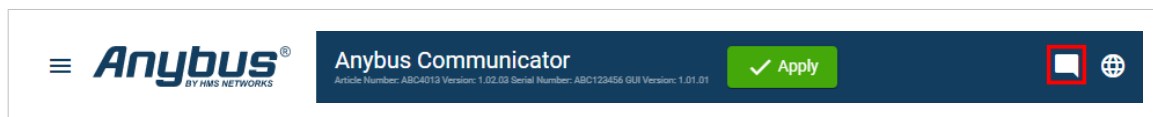

Figure 95. Configuration note, comment icon

2. To add a new configuration note, click **Add**.

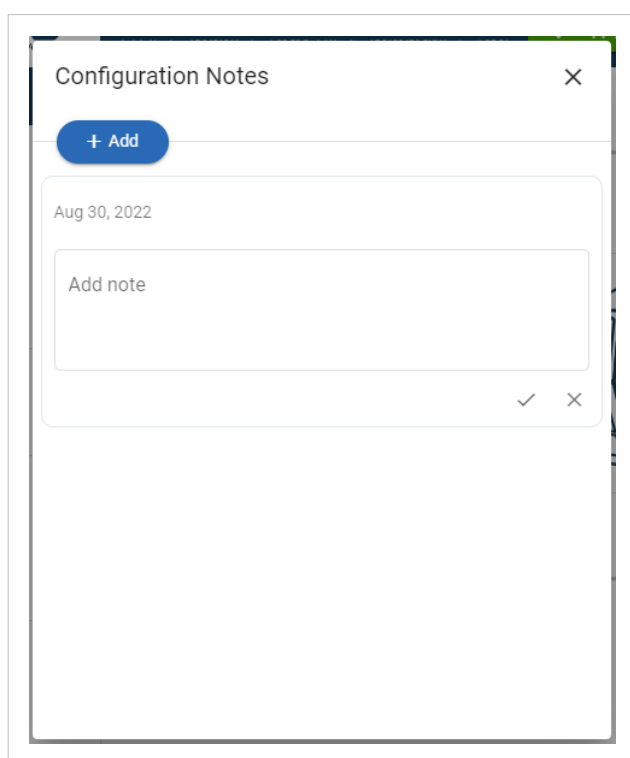

Figure 96. Add new configuration note

3. Write your configuration note and click **accept** ✓ .

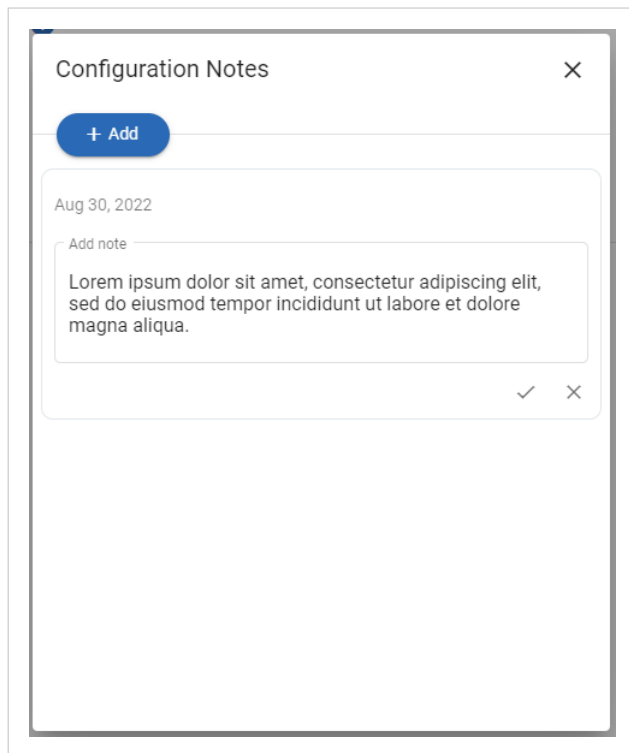

Figure 97. Write a configuration note

The configuration note is added to the list.

4. To close the window, click **close** ✕ .
5. To save the configuration note, click **Apply** in the web-interface header, and follow the instructions.

### 8.12.2. View and Edit Configuration Notes

To view and/or edit a note, click on the **comments** icon .



Figure 98. Example: The comment icon indicates that there are three added notes

The configuration notes are listed in the **Configuration Note** window.

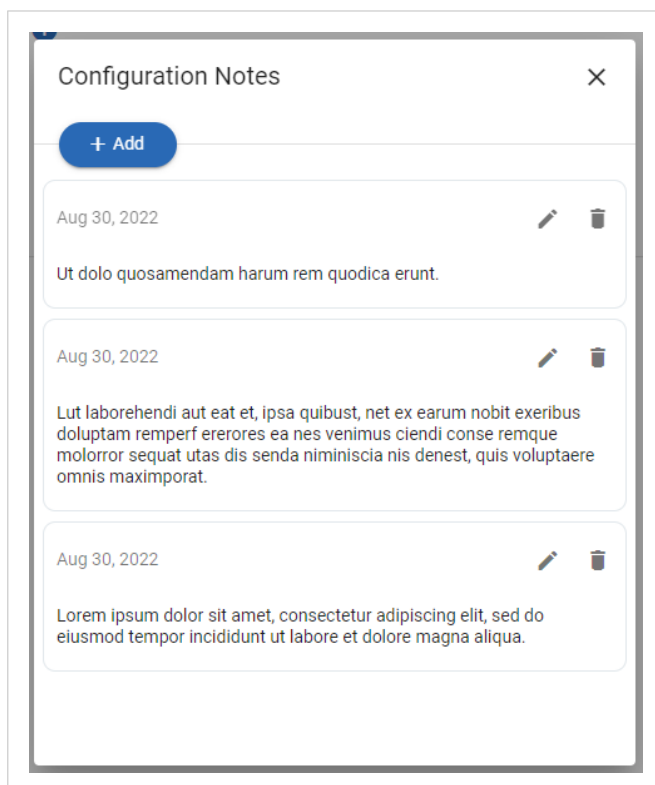

Figure 99. Example: The Configuration Notes window with added notes

## 8.13. Apply Configuration

### Before You Begin

**NOTE**

When you apply the configuration, any existing configuration is overwritten.

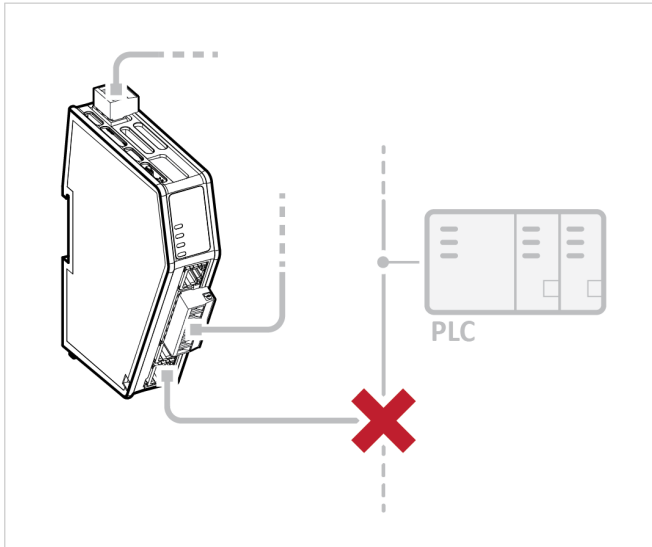

Figure 100. Disconnect the Communicator from the PROFIBUS network

Before you can apply the configuration, ensure that there is no active communication on the PROFIBUS network where the Communicator is connected.

### Procedure

To make the settings take effect, download the configuration to the Communicator:

1. In the web-interface header, click **Apply**



2. To confirm download, click **Apply**.  
The configured settings are downloaded and applied to the system.

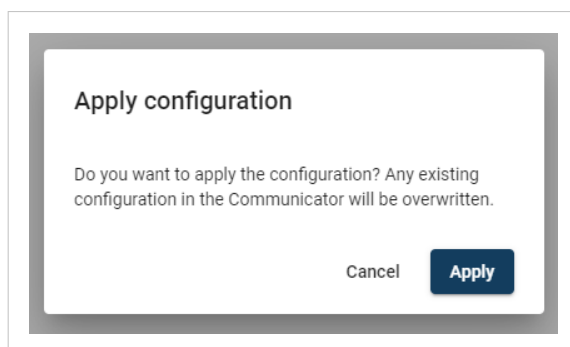

## 8.14. To Use an Existing Configuration

When you have configured a Communicator and want to use the same settings to configure additional Communicator, do the following.

### Procedure

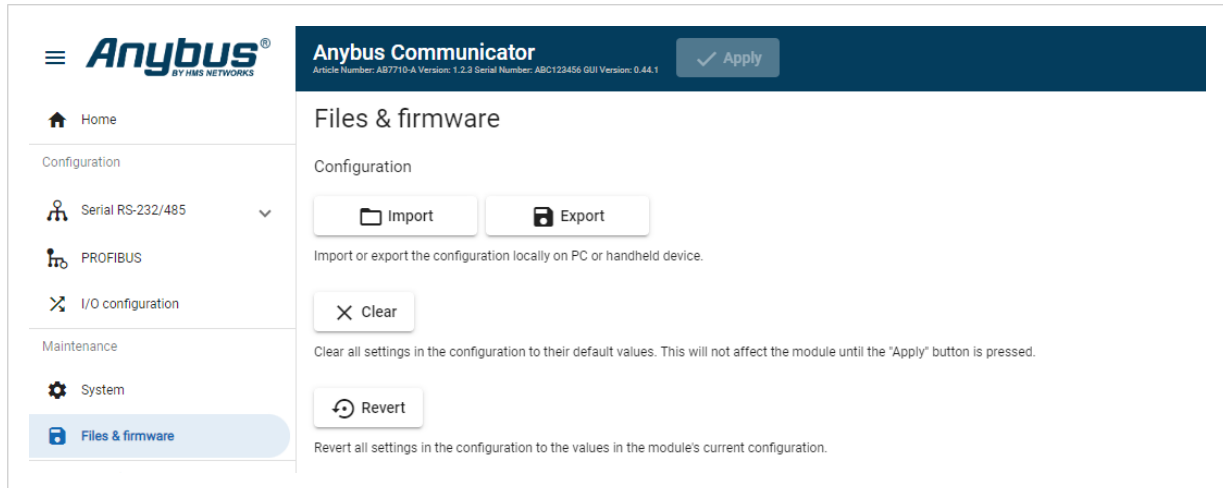

Figure 101. Files & firmware page

In the built-in web-interface of the Communicator with the configuration you want to use:

1. On the **Files & firmware** page, click **Export**  
The configuration is saved in a configuration file and downloaded to your PC.

In the built-in web-interface of the new Communicator to be configured:

2. On the **Files & firmware** page, click **Import**
3. In the Import configuration window, click **Select file (.conf)**.
4. In the Open dialog box, browse to and select the configuration file and click **Open**.
5. To import the configuration file, click **Import**.

### Result

All the configuration settings are imported.

To apply the settings, click **Apply** in the web-interface header, and follow the instructions.

## 8.15. To Use a Communicator Classic Configuration

### Before You Begin



#### NOTE

Only the Communicator Classic serial configuration settings can be imported.

The I/O data map and high-level network settings are not supported and must be set manually in the Communicator built-in web interface.

#### Communicator Classic Classic configuration intended use

The intended use of the Communicator Classic configuration import is to:

- convert custom protocols.
- get a new Communicator unit up and running quickly and then complete the configuration in the Communicator built-in web interface.

#### Configuration files containing standard Modbus RTU commands

- It is not recommended to import Communicator Classic configuration files containing standard Modbus RTU commands if you need to be able to easily make change to the imported configuration.
- When standard Modbus RTU commands are imported, they are converted to Custom Request/Response transactions. See [Communication Serial Protocol \(page 48\)](#).
- The behavior of the imported standard Modbus RTU commands is preserved, but adding or changing Modbus RTU commands in Custom Request/Response mode is more difficult than in Modbus RTU mode.

### Procedure

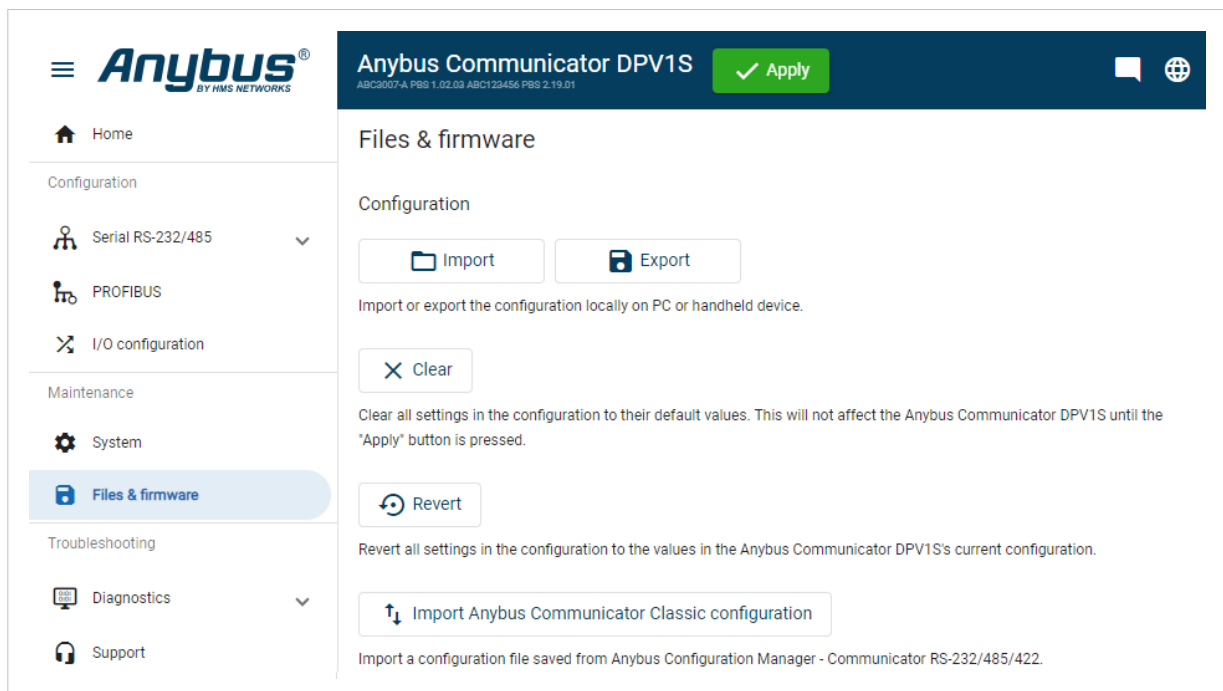

Figure 102. Files & firmware page

1. On the **Files & firmware** page, click **Import Anybus Communicator Classic configuration**
2. In the **Import Anybus Communicator Classic configuration** window, click **Select file (.cfg)**.

3. In the Open dialog box, browse to and select the configuration .cfg file and click **Open**.
4. If you want to import a name file, click **Select name file (.cfx)**.
5. In the Open dialog box, browse to and select the configuration .cfx file and click **Open**.
6. To import the configuration, click **Import**.

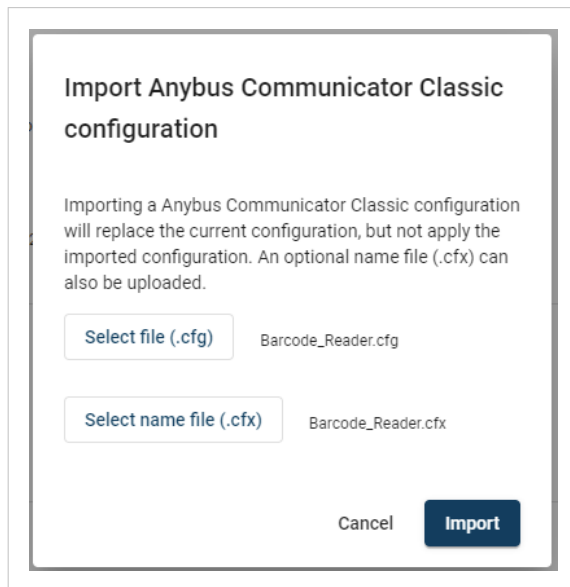
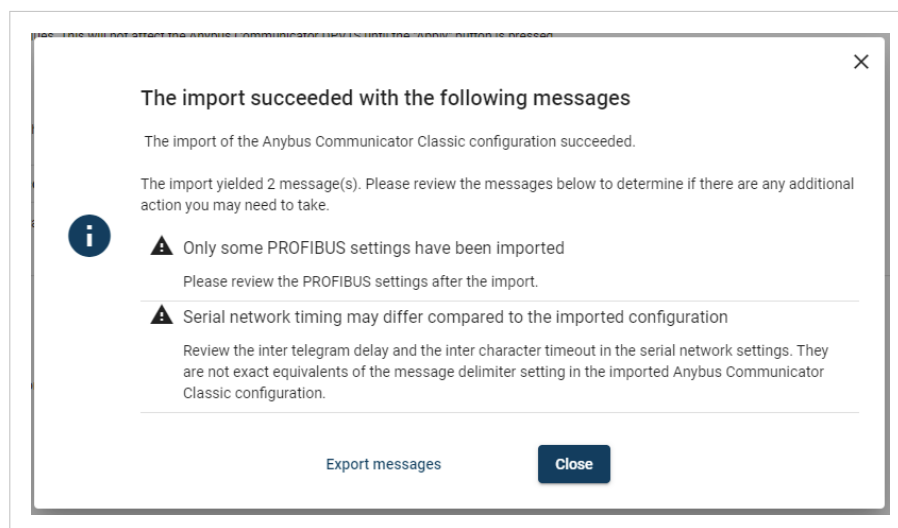

Figure 103. Example, selected .cfg and .cfx files

## Result

The Communicator Classic serial configuration settings are imported.



A window with messages about the imported configuration appear.

In the list you can view the settings that are fully supported or adjusted to work with Communicator and which settings that are not supported and must be set manually in the built-in Communicator interface.

To export the messages in an Excel XLS file, click **Export Messages**.

To apply the settings, click **Apply** in the web-interface header, and follow the instructions.

Figure 104. Example, list with messages about the import

## 9. PLC Configuration

### 9.1. PLC Device Security



#### IMPORTANT

It is important to maintain the cybersecurity of the Communicator.

Before connecting the Communicator to a PLC, ensure the PLC is configured and installed in accordance with the PLC supplier hardening guidelines.

### 9.2. Export I/O Configuration

When configuring the communication between the PLC and the nodes on the subnetwork, use the I/O data map as a specification to ensure that the transactions match.

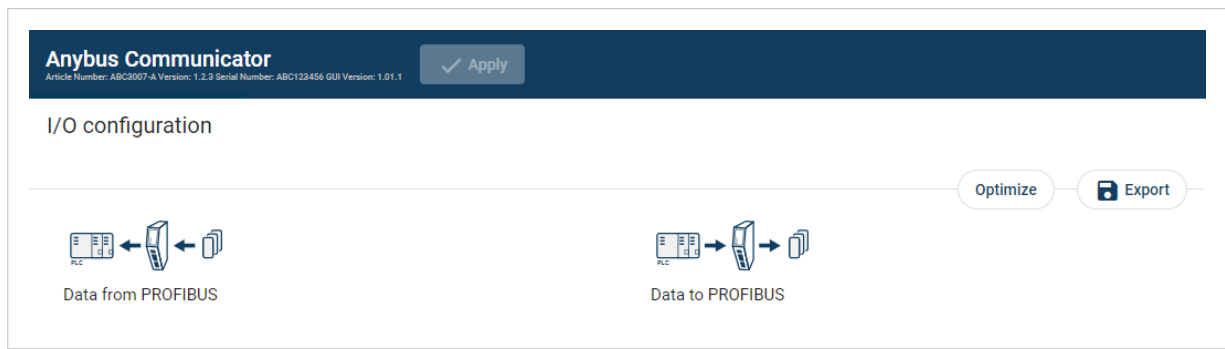

Figure 105. I/O configuration page

On the **I/O configuration** page you can export the I/O data map in an Excel XLS file, where all the nodes and transactions are listed.

To export the I/O data map:

1. Click **Export**.  
An Excel XLS file with the mapping is downloaded to your PC.

## 9.3. Export Product GSD File

Option if the PLC program requires a product file, GSD (General Station Description) file, describing how the Communicator can be used on the high level network.

### Procedure

You find the *PROFIBUS GSD* file on the Communicator built-in web interface **PROFIBUS** page, **Files & firmware** page and on the **Support** page.

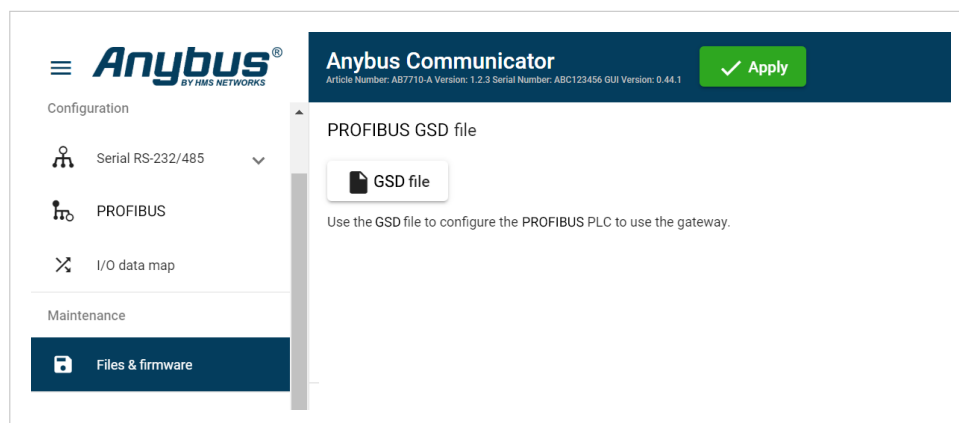

Figure 106. Export Product GSD File

To export the GSD file:

Click **GSD file**.

The GSD file is downloaded to your PC.

### About the Product GSD Files

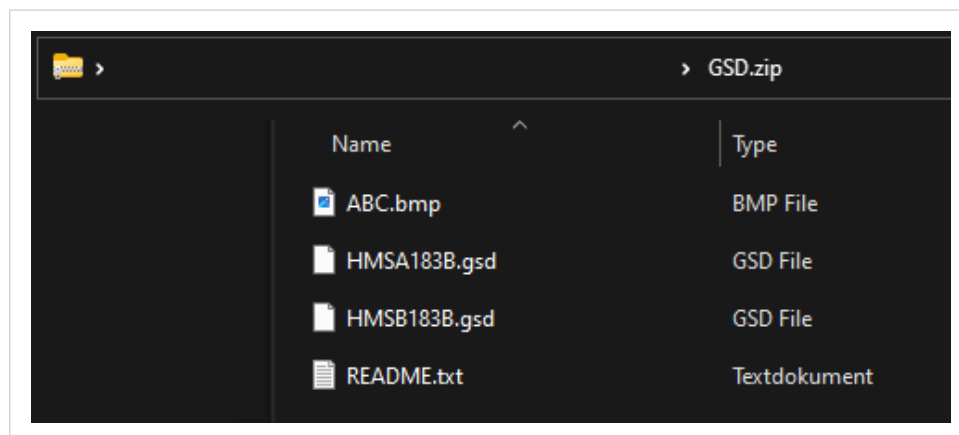

Figure 107. GSD.zip with HMSA183B.gsd and HMSB183B.gsd files

There are two GSD (General Station Description) files included in the Communicator GSD zip file:

- **HMSA183B.gsd**  
Use this GSD file when the **Advanced settings: Use legacy mode** and **Allow any Module Mapping** are disabled.
- **HMSB183B.gsd**  
Use this GSD file when the **Advanced settings, Allow any Module Mapping** is enabled.  
For more information about the *HMSB183B.gsd* file, see [GSD File Compatible With Allow Any Module Mapping \(page 98\)](#).

## 9.4. How to Use GSD File Modules

When configuring the PROFIBUS communication, ensure that the I/O sizes in the PROFIBUS master match the I/O sizes set on the Communicator **PROFIBUS** page, see [PROFIBUS Network Settings \(page 93\)](#).

Import the Communicator GSD file into TIA portal and combine the modules to get the correct I/O size.



### NOTE

Fill unused module slots with the value Empty.

Table 1. Modules available in the Communicator GSD file

Mod_name	Config	Module-Reference	In/Out	Size
Empty module	0x00	1	N/A	0
1 byte input module	0x90	2	In	1 byte
2 bytes input module	0xD0	3	In	1 word (2 bytes)
4 bytes input module	0xD1	4	In	2 words (4 bytes)
8 bytes input module	0xD3	5	In	4 words (8 bytes)
16 bytes input module	0xD7	6	In	8 words (16 bytes)
32 bytes input module	0xDF	7	In	16 words (32 bytes)
64 bytes input module	0x40, 0xDF	8	In	32 words (64 bytes)
128 bytes input module	0x40, 0xFF	9	In	64 words (128 bytes)
1 byte output module	0xA0	10	Out	1 byte
2 bytes output module	0xE0	11	Out	1 word (2 bytes)
4 bytes output module	0xE1	12	Out	2 words (4 bytes)
8 bytes output module	0xE3	13	Out	4 words (8 bytes)
16 bytes output module	0xE7	14	Out	8 words (16 bytes)
32 bytes output module	0xEF	15	Out	16 words (32 bytes)
64 bytes output module	0x80, 0xDF	16	Out	32 words (64 bytes)
128 bytes output module	0x80, 0xFF	17	Out	64 words (128 bytes)

### Example 12. How to combine modules

In this example we configure the following sizes:

- Data size to PROFIBUS: 95 bytes  
Combine modes: 64 + 16 + 8 + 4 + 2 + 1  
Size: [ 0xDF + 0xD7 + 0xD3 + 0xD1 + 0xD0 + 0x90 ]
- Data size from PROFIBUS: 58 bytes  
Combine modes: 32 + 16 + 8 + 2  
Size: [ 0xEF + 0xE7 + 0xE3 + 0xE0 ]

**Example 13. Fill unused module slots**

The gateway cannot move positions and it expects data of a certain size at each position between the combine modes.

Therefore, unused module slots needs to be filled with the value Empty.

In this example we use an I/O size of 35 bytes.

Combine modes: 1 + 2 + 32

To fill the positions, we add Empty where the Combine modes 4, 8, 16, 64 and 128 are expected.

1 byte + 2 bytes + Empty + Empty + Empty + 32 bytes + Empty + Empty

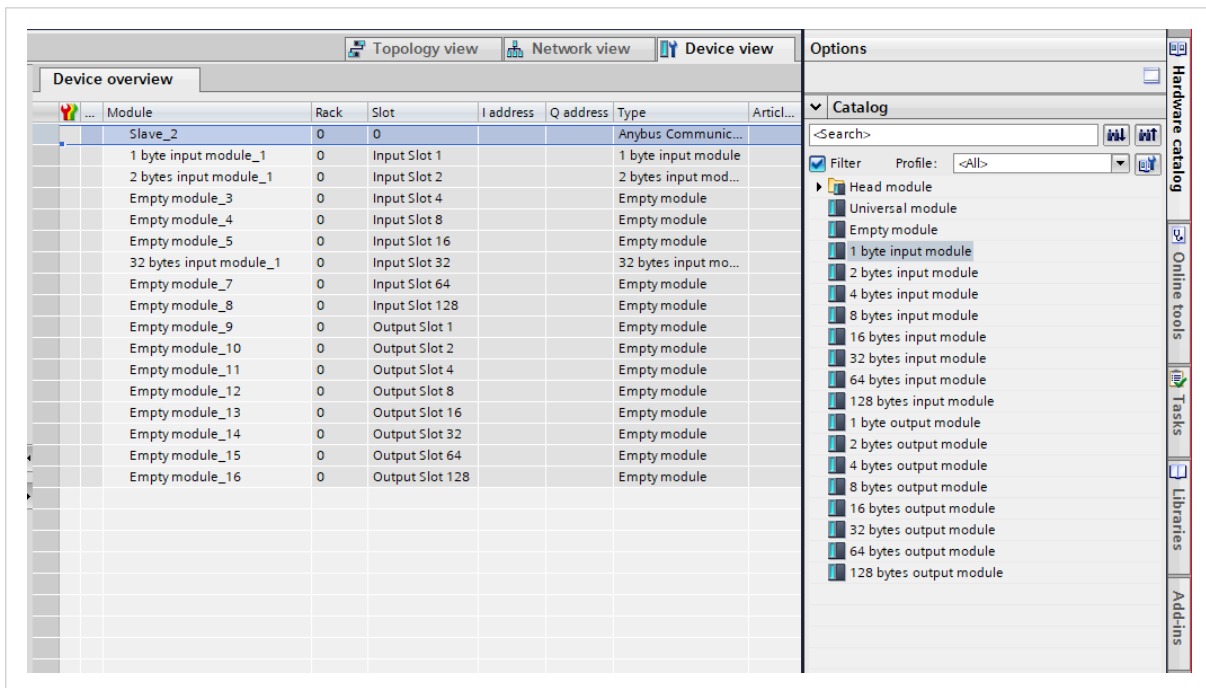

Figure 108. Example, fill unused module slots in TIA Portal

## 10. Verify Operation

### Before You Begin

Ensure that the Communicator is connected to your PC, to a power supply and to the OT network.

See [Installation \(page 16\)](#).

### 10.1. Communicator Status Monitor

On the Home page, you can get a quick overview of the network and the Communicator operating status.

The screenshot displays the Anybus Communicator DPV1S Home page. The interface includes a navigation menu on the left with sections for Configuration, Maintenance, and Troubleshooting. The main content area shows three status cards:

- PROFIBUS:** Data exchange is not started. PROFIBUS address: 126. Data flow: ↑ 2 byte(s) ↓ 0 byte(s). Includes a diagram of a PLC connected to a network.
- Anybus Communicator DPV1S:** Operational. Includes a legend for Gateway (green), PROFIBUS (green), and Serial (red), and an image of the device.
- Serial RS-232/485:** Data exchange is not started. Modbus RTU, RS-232, 9600 baud. Includes a "New node" indicator.

Figure 109. Home page

### Gateway Status

Overview the Communicator LED indications remotely.

Refer to [Communicator LED Indicators \(page 121\)](#).





### Node Status

Overview the status for each node added to the subnetwork.

### Network Status and Settings

Overview communication status and the current networks settings.

## Status Symbols

Symbol	Description
	Internal error has occurred, and operation cannot be guaranteed.
	Out of Specification.
	Check Function: <ul style="list-style-type: none"> <li>• Initial state where non network components are started and configured.</li> <li>• Network startup in progress.</li> <li>• Invalid configuration detected.</li> </ul>
	Normal operation.

## 10.2. Communicator LED Indicators



**NOTE**

Before you can verify operation, you must configure the Communicator.

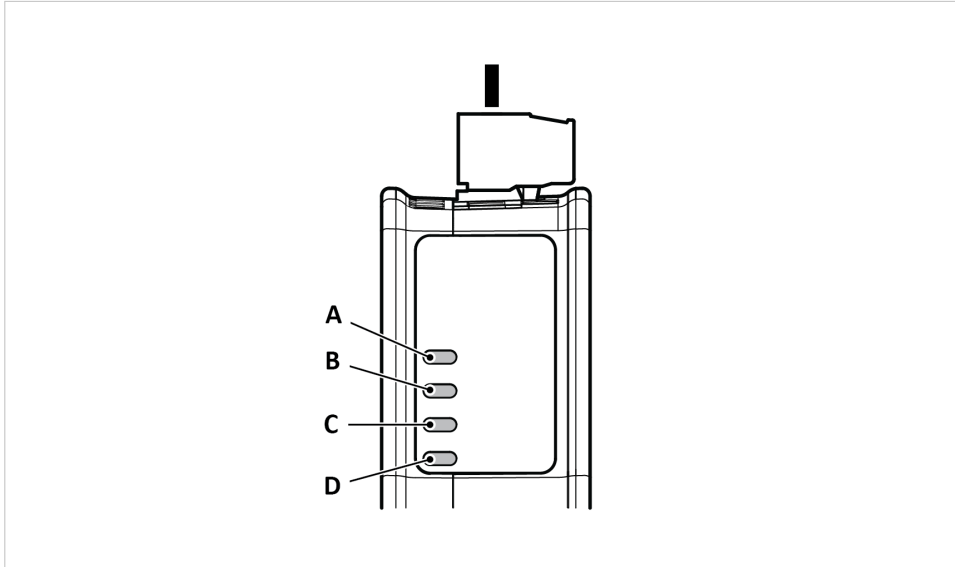

Figure 110. Communicator status (A), High level Network/Client (B), Subnetwork 2 (C) and (D) Security Switch

	LED A	LED B	LED C	LED D
Operation status	Gateway status	PROFIBUS	Subnetwork	Security switch
Off	No power	No data exchange	No power/Subnetwork not running/Node is switched off via a control word	No power/Security switch is unlocked
Green, flashing	Startup phase	Clear, data exchange	Running, one or more nodes are offline	N/A
Green, solid	Operational	Operate, data exchange	Running	Security switch is locked
Red, solid	N/A	FATAL event	N/A	N/A
Red, one flash	N/A	Parameterization error	N/A	N/A
Red, two flash	N/A	PROFIBUS configuration error	N/A	N/A
Green/Red, flashing	Power up self-test/ Firmware update/Firmware recovery	N/A	N/A	N/A

### Fatal Error and Exception Error

**Fatal error:** A fatal error causes the Communicator firmware application to crash in an uncontrolled manner.

**Exception error:** An exception error causes the Communicator to enter a controlled error state. The Communicator firmware application is still running.

LED	Fatal error	Exception error
A	Red, solid	Red, solid
B	Red, solid	Off
C	Red, solid	Off
D	Off	Off

## 11. Use Cases

### 11.1. Temperature Regulator - Modbus RTU Use Case

#### 11.1.1. About the Use Case

The purpose of this use case is to explain how to use the **Modbus RTU** serial protocol.

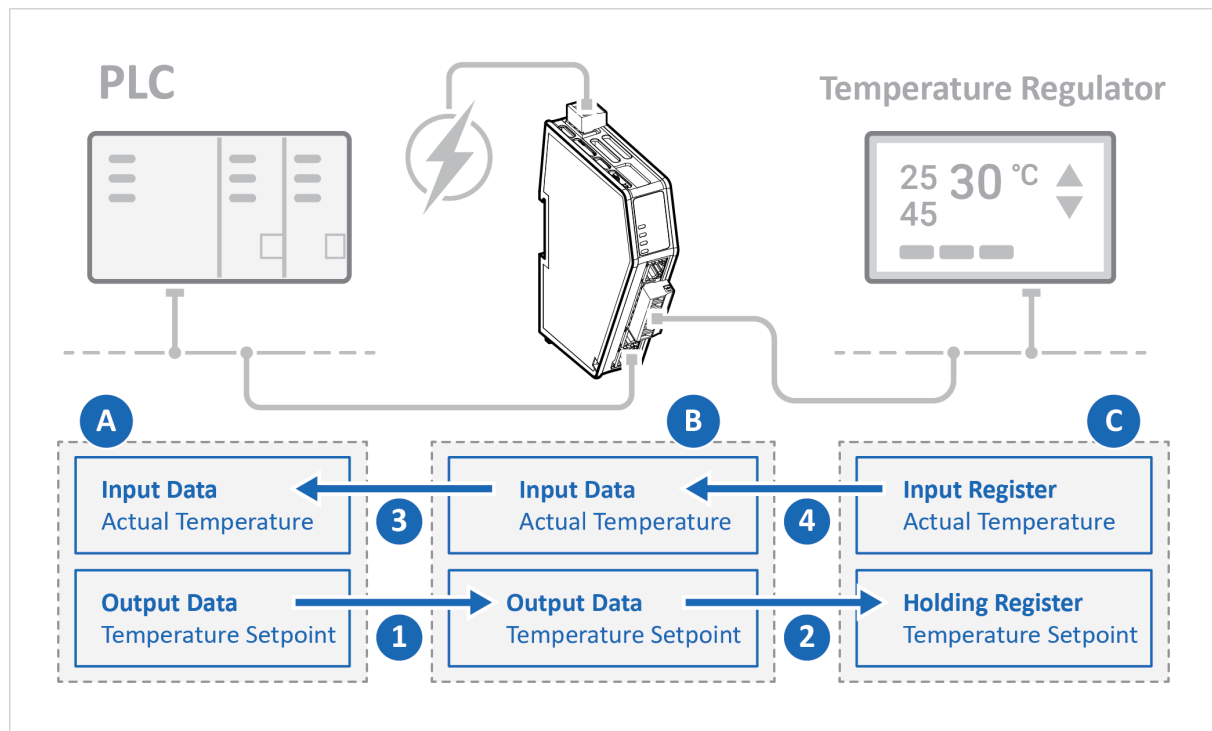

Figure 111. Temperature Regulator - Modbus RTU Use Case

In this use case we use the Communicator to enable data exchange between an Temperature Regulator and a PLC.

The use case describes how to map the communication in the Communicator.

The Temperature Regulator is connected to the serial subnetwork via a custom RS-232 protocol.

The PLC is connected to an PROFIBUS network (high level network).

#### 11.1.2. Before You Begin

- Connect the Communicator configuration port to your computer.
- Power on the Communicator.
- Ensure that your computer can find the Communicator IP address.
- Enter the Communicator built-in web interface of the.

For more information refer to [Communicator Configuration \(page 43\)](#).

### 11.1.3. Choose Serial Protocol Type

The Temperature Regulator is using a request/response protocol to access parameters addressed with index and sub index.

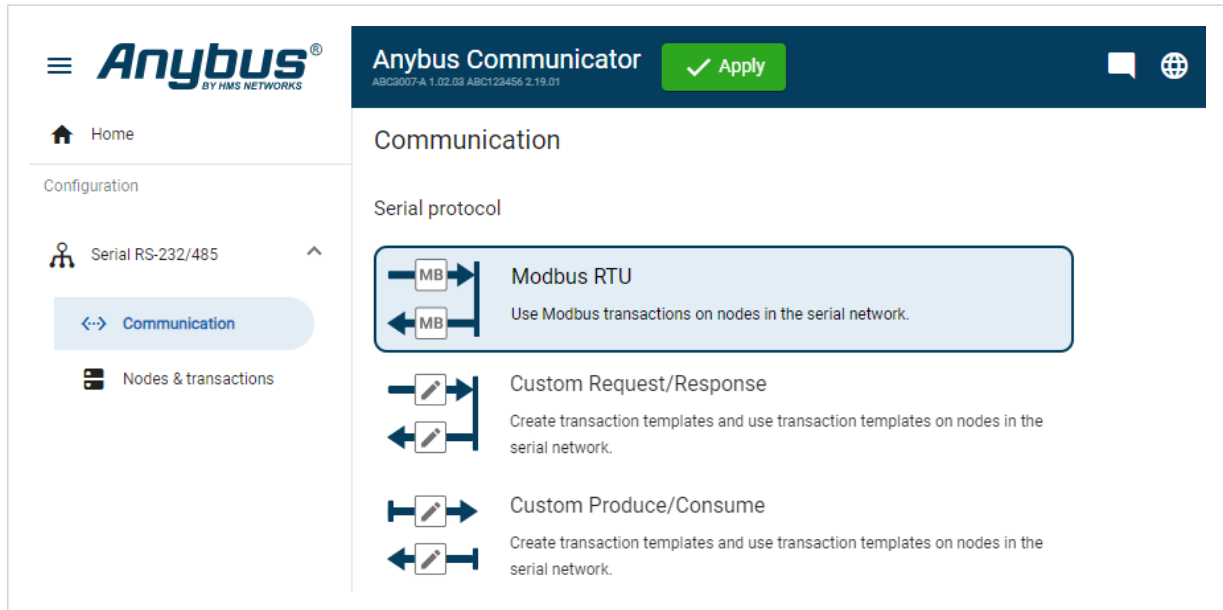

Figure 112. Communication page, **Modbus RTU**

On the **Serial RS232/485** page, select **Modbus RTU**.

### 11.1.4. Setup Serial Communication

Set up the communication between the Communicator and the Temperature Regulator.

In the **Serial RS232/485** page, configure the **Communication** settings.

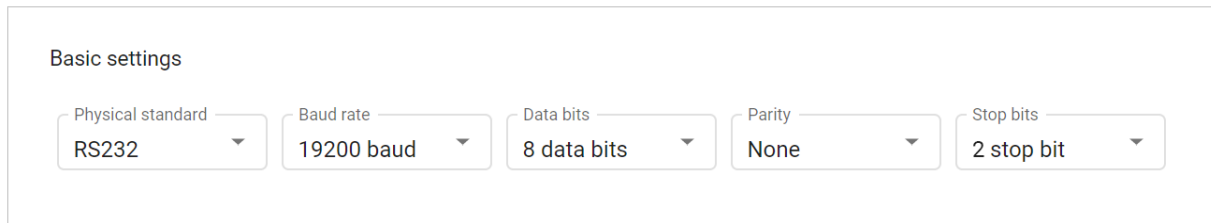

Figure 113. Serial RS232/485, Basic settings

Table 2. Used the following settings:

Frame objects	Value
Physical standard	RS-232
Baud rate	19200 baud
Data bits	8 bits
Parity	None
Stop bits	2 stop bit

### 11.1.5. Setup the Node

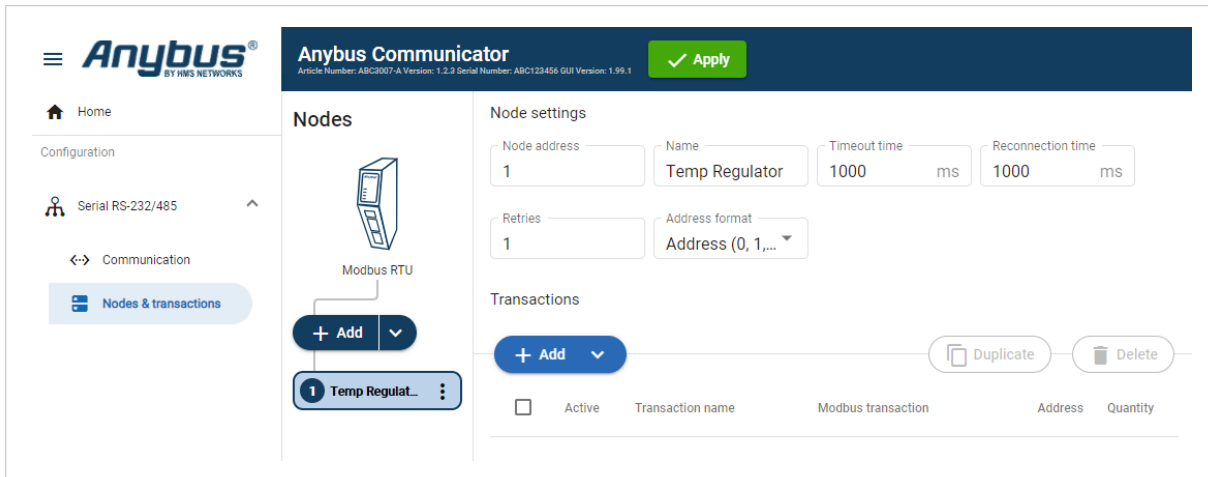

Figure 114. Add the Temperature Regulator node

1. Add a node and select it.
2. In Node settings, configure the node with the following settings:

Node settings	Value
SubDevice address	240
Name	Temp Regulator
Timeout time	1000 ms
Reconnection time	1000 ms
Retries	1
Address format	Register

### 11.1.6. Setup the Transactions

Set up the communication between the node and the master.

In this example, the communication between the Temperature Regulator and the PLC.

The Temperature Regulator has two Modbus transactions:

- One registers holding the setpoint temperature.
- One registers holding the actual temperature.

#### Configure the temperature setpoint transaction

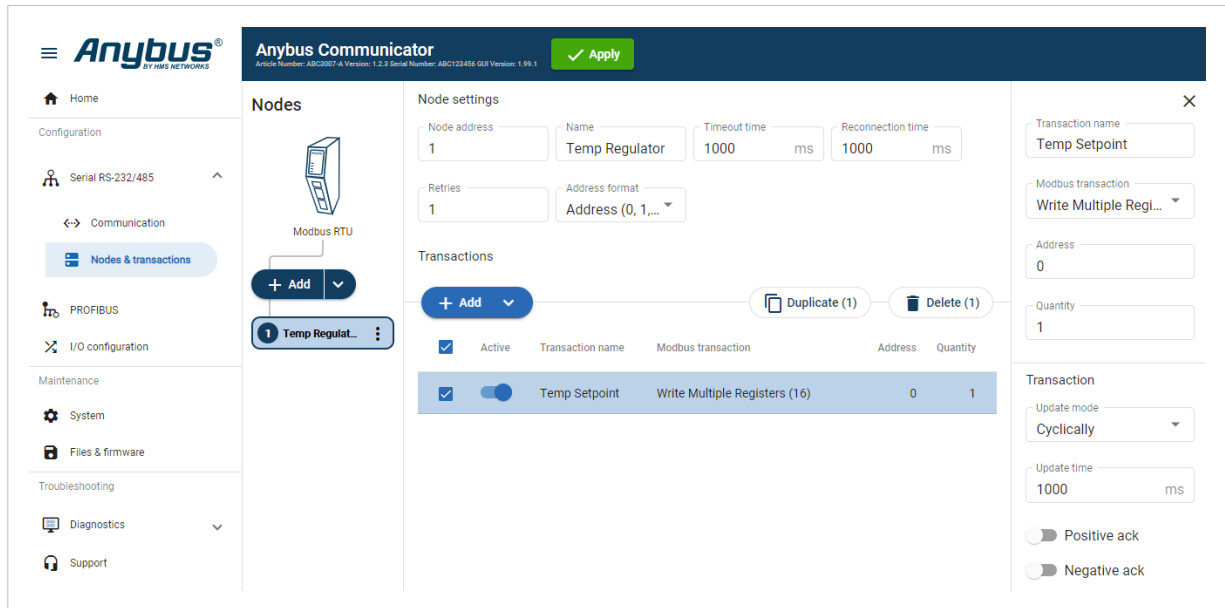

Figure 115. Temperature setpoint transaction

1. Select the **Temp Regulator** node.
2. To add a transaction, click **Add**.
3. Select the transaction to configure.
4. In the transaction sidebar, on the right side of the screen. Enter values for the transaction settings.

Table 3. Setpoint temperature transaction settings

Setting	Value	Description
Transaction name	Temp Setpoint	Give the transaction a name.
Modbus transaction	Write Multiple Registers (16)	The PLC writes a block of contiguous registers to the temperature regulator.
Address/ Register	Address: 0 Register: 1	Address 0 is Register 1.
Quantity	1	The transaction will address one data object.
Update mode	Cyclically	The temperature regulator sends a new message cyclically, every 1000 ms.
Update time	1000 ms	The update cycle is 1000 ms.

### Configure the actual temperature transaction

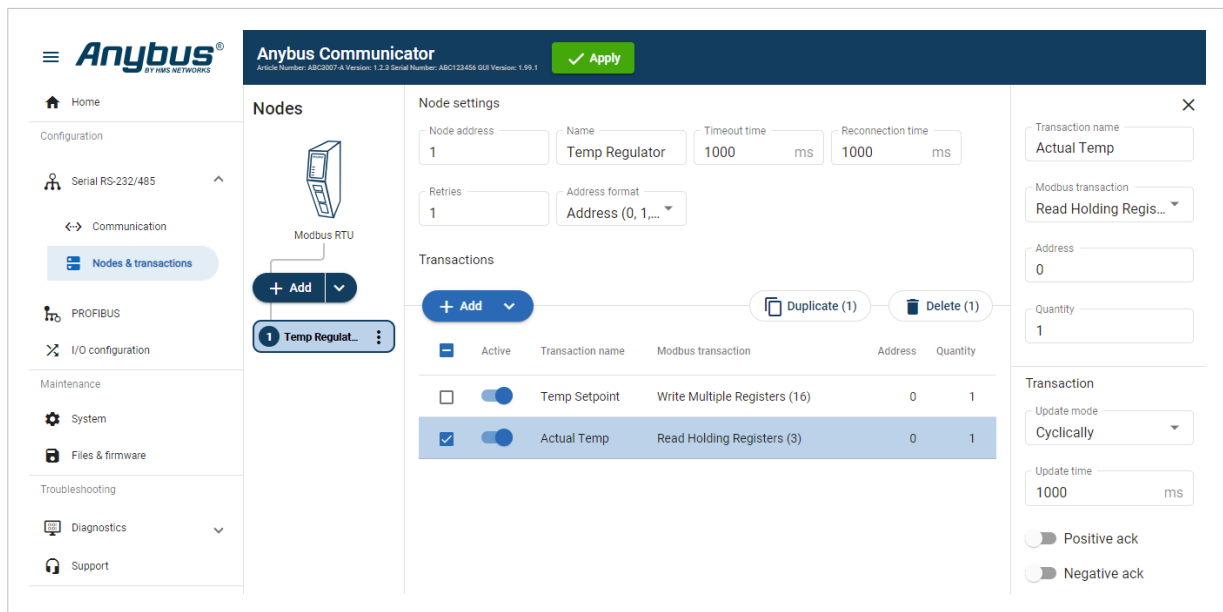

Figure 116. Actual temperature transaction

1. To add a second transaction, click **Add**.
2. Select the transaction to configure.
3. In the transaction sidebar, on the right side of the screen. Enter values for the transaction settings.

Table 4. Actual temperature transaction settings:

Setting	Value	Description
Transaction name	Actual Temp	Give the transaction a name.
Modbus transaction	Read Holding Registers (3)	This register read the actual temperature from the temperature regulator to the PLC.
Address	Address: 0 Register: 1	Address 0 is Register 1.
Quantity	1	The transaction will address one data object.
Update mode	Cyclically	Default value, can not be changed.
Update time	1000 ms	The update cycle is 1000 ms.

### 11.1.7. Check the I/O Configuration

The transactions to and from the Temperature Regulator are mapped as follows in the **I/O configuration** page.

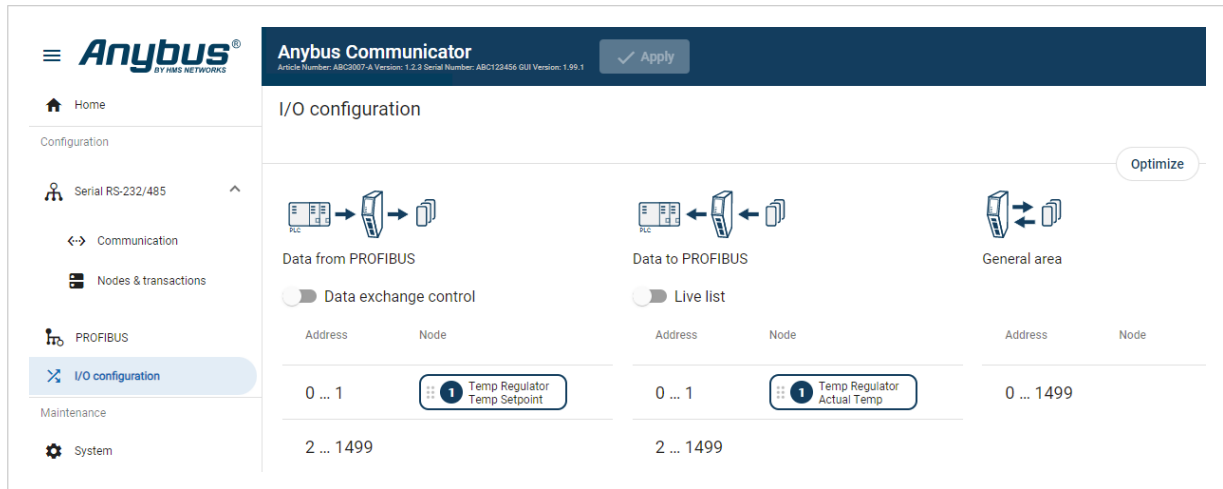

Figure 117. I/O configuration page

Address	Data to PROFIBUS
0-1	Setpoint temperature from PROFIBUS to the Temperature Regulator.

Address	Data from PROFIBUS
0-1	Actual temperature from the Temperature Regulator to PROFIBUS.

## 11.2. AC Motor Drive - Custom Request/Response Use Case

### 11.2.1. About the Use Case

The purpose of this use case is to explain how to use the **Custom Request/Response** serial protocol.

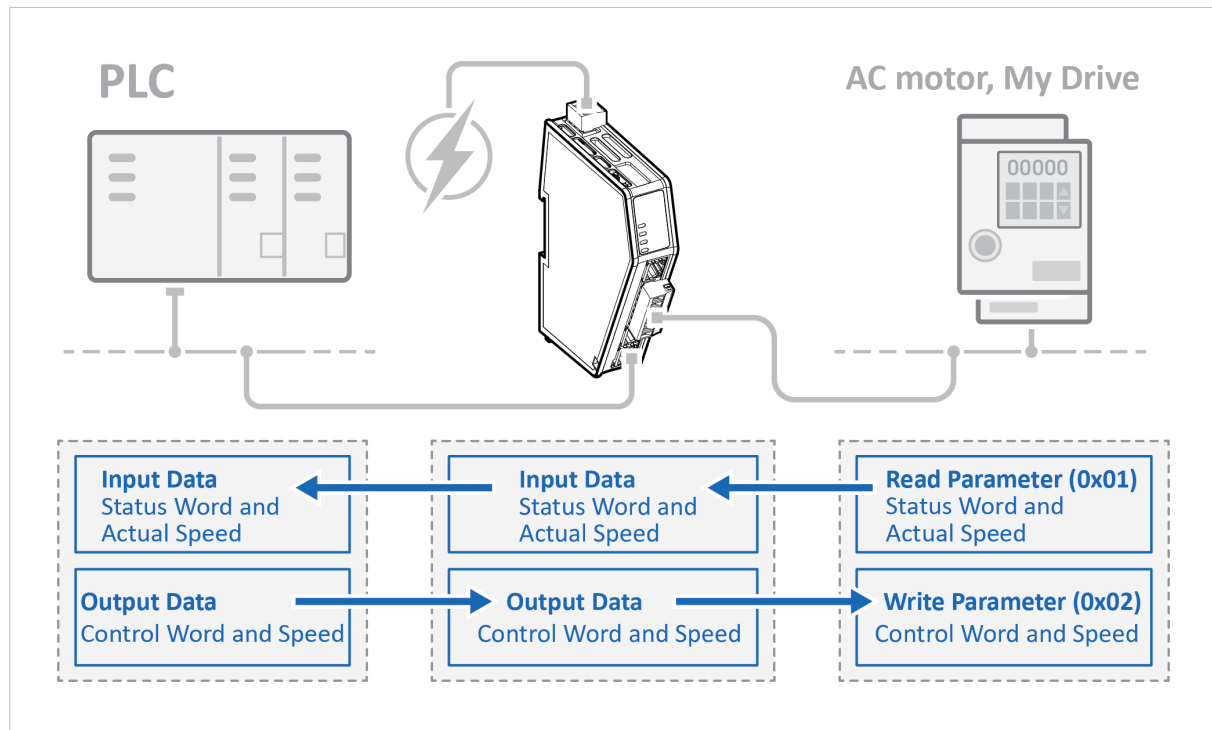

Figure 118. AC Motor Drive - Custom Request/Response Use Case

In this use case we use the Communicator to enable data exchange between an AC motor, of the type My Drive, and a PLC.

The use case describes how to map the communication in the Communicator.

My Drive is connected to the serial subnetwork via a custom RS-485 protocol.

The PLC is connected to an PROFIBUS network (high level network).

We use the Custom Request/Response serial protocol and create customized transaction template to map up:

- Status word and actual speed from My Drive to the PROFIBUS network.
- Control word and speed from the PROFIBUS network to My Drive.

### 11.2.2. Before You Begin

- Connect the Communicator configuration port to your computer.
- Power on the Communicator.
- Ensure that your computer can find the Communicator IP address.
- Enter the Communicator built-in web interface of the.

For more information refer to [Communicator Configuration \(page 43\)](#).

### 11.2.3. Choose Serial Protocol Type

My Drive is using a request/response protocol to access parameters addressed with index and sub index.

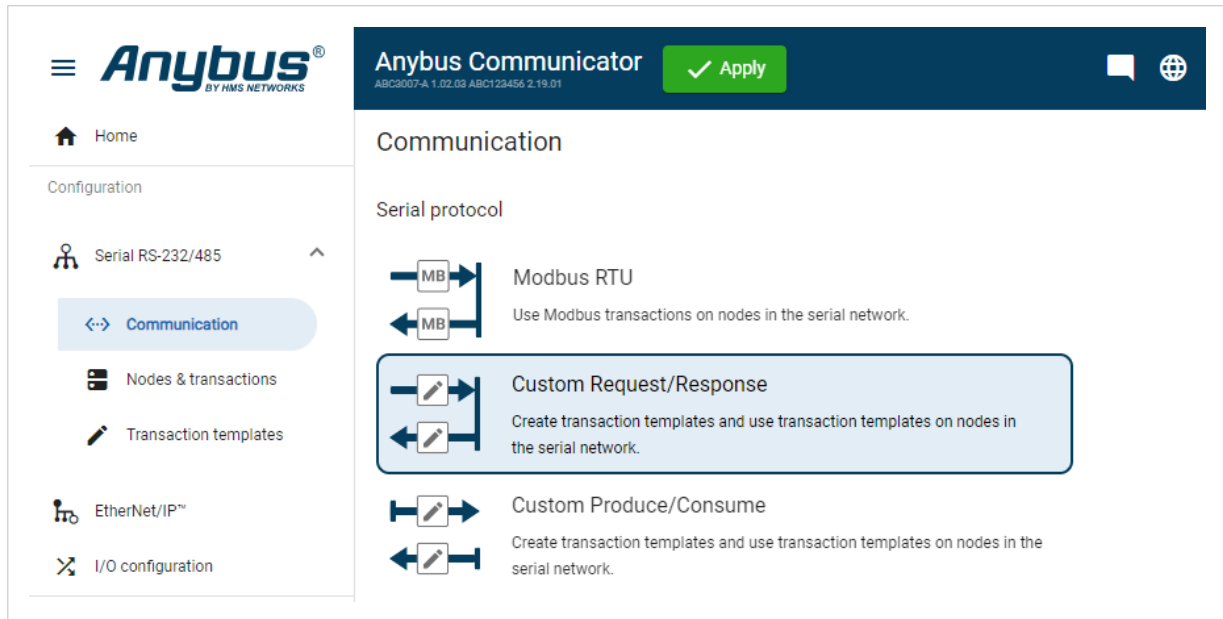

Figure 119. Communication page, **Custom Request/Response**

On the **Serial RS232/485** page, select **Custom Request/Response**.

### 11.2.4. Setup Serial Communication

Set up the communication between the Communicator and My Drive.

In the **Serial RS232/485** page, configure the **Communication** settings.

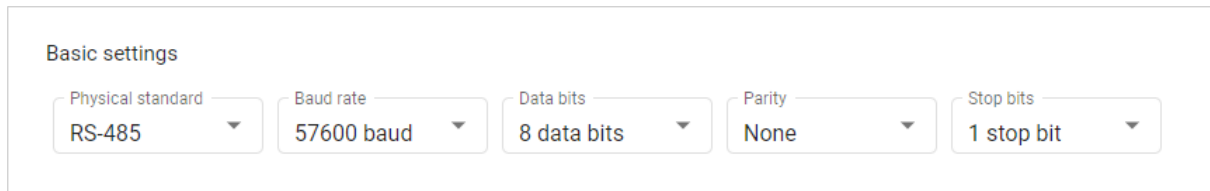

Figure 120. Serial RS232/485, Basic settings

Table 5. Used the following settings:

Frame objects	Value
Physical standard	RS-485
Baud rate	57600 baud
Data bits	8 bits
Parity	None
Stop bits	1 stop bit

### 11.2.5. Create Transaction Templates

All frames are verified using a CRC-16-IBM checksum.

My Drive is using a request/response protocol to access parameters addressed with index and sub index.

Map up control word, speed from PROFIBUS to My Drive and status word and actual speed from the drive to PROFIBUS.

#### Create Read Parameter (0x01)

The Communicator reads values delivered from to the My Drive node on to the PLC.

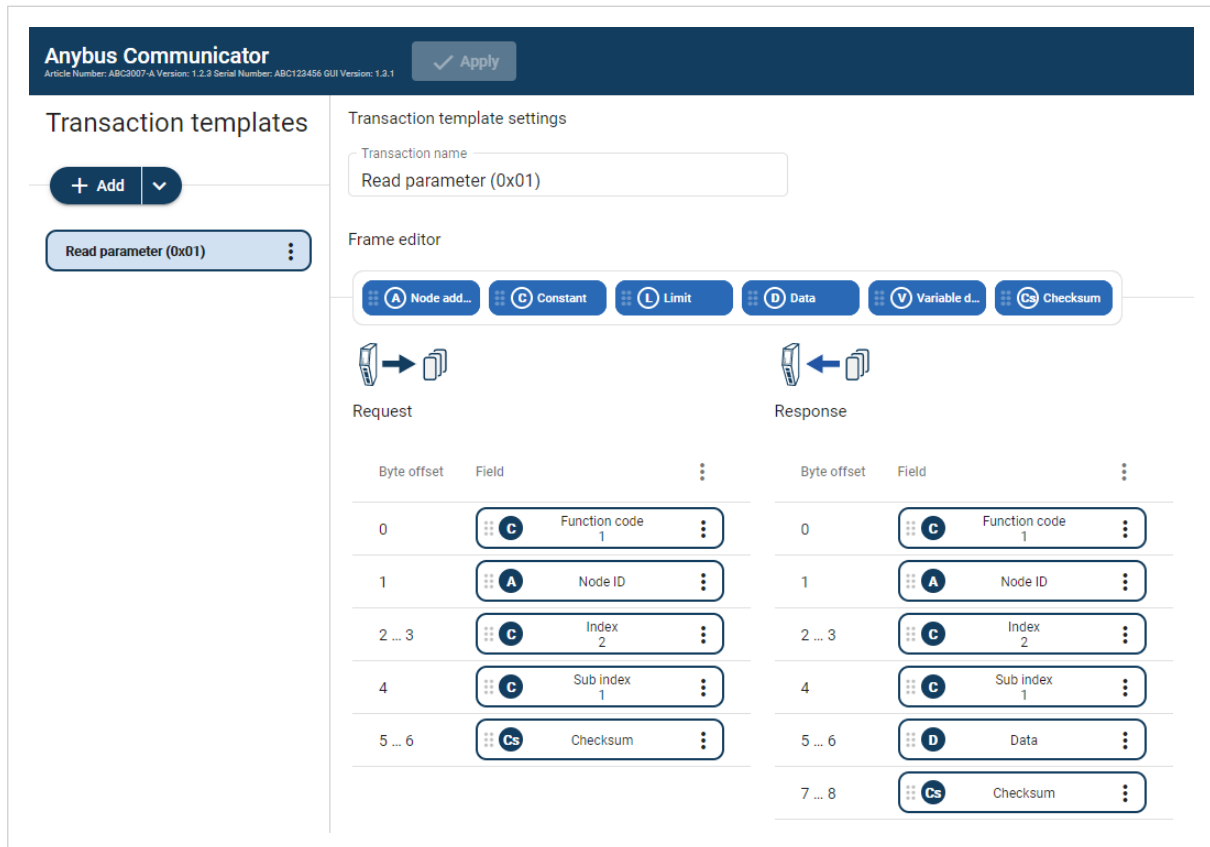

Figure 121. Read Parameter (0x01)

1. Add an **Empty template** and select it.
2. Name the template **Read parameter (0x01)**.
3. In the Frame editor **Request** area, add five **frame objects** with the following settings:

Table 6. Request frame objects

Frame objects	Name	Bytes/Length	Type/Checksum type	Endianness	Fixed field	Value
Constant	Function code	1	Byte	N/A	Yes	N/A
Node address	Node ID	1	Byte	N/A	N/A	N/A
Constant	Index	2	Word (two bytes)	Big-endian	No	Min 0 Max 1000
Constant	Sub index	1	Byte	N/A	No	Min 0 Max 255
Checksum	Checksum	2	CRC	N/A	N/A	N/A

4. In the Frame editor **Response** area, add six **frame objects** with the following settings:

Table 7. Response frame objects

Frame object	Name	Bytes/Length	Type/Checksum type	Endianness	Fixed field	Value
Constant	Function code	1	Byte	N/A	Yes	N/A
Node address	Node ID	1	Byte	N/A	N/A	N/A
Constant	Index	2	Word (two bytes)	Big-endian	No	Min 0 Max 1000
Constant	Sub index	1	Byte	N/A	No	Min 0 Max 255
Data	Data	2	Byte	N/A	Yes	N/A
Checksum	Checksum	2	CRC	N/A	N/A	N/A

### Create Write Parameter (0x02)

The Communicator writes values delivered from the PLC to the My Drive node.

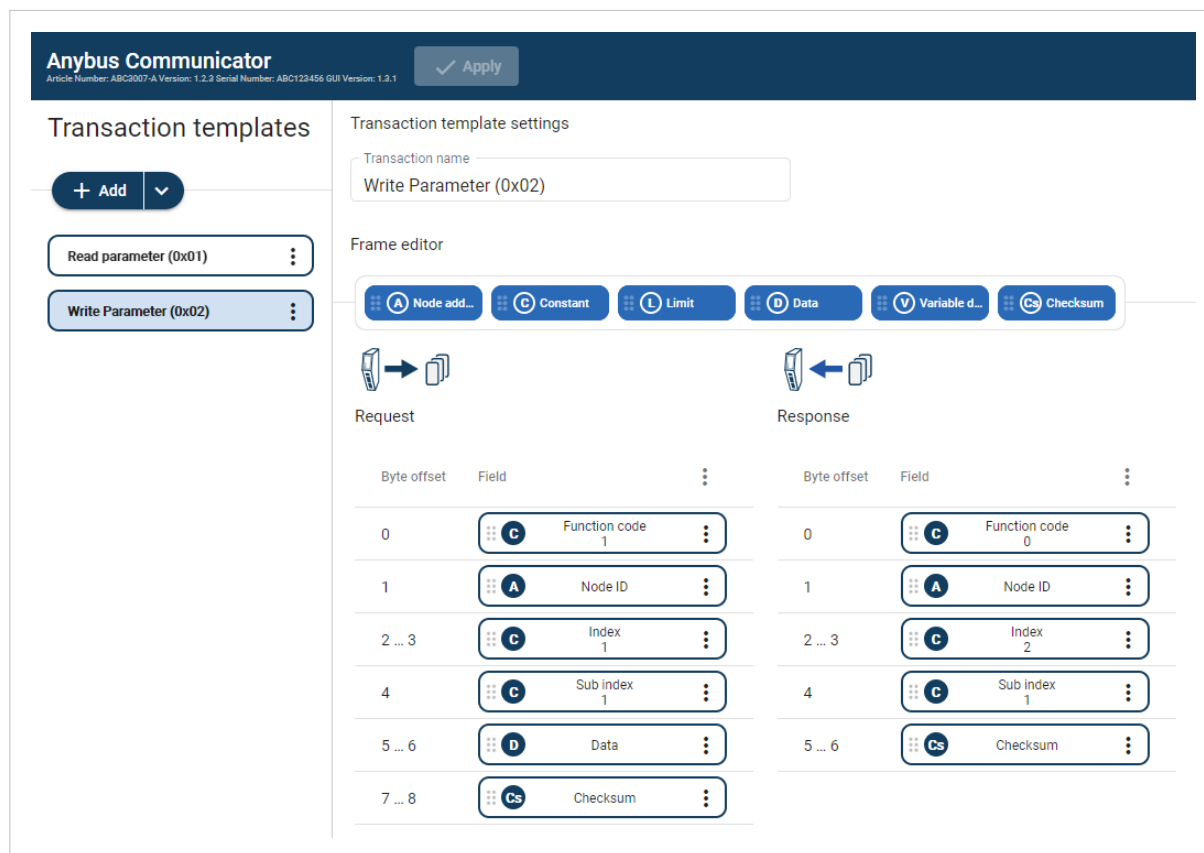

Figure 122. Write Parameter (0x02)

1. Add an **Empty template** and select it.
2. Name the template **Write parameter (0x02)**.
3. In the Frame editor **Request** area, add six **frame objects** with the following settings:

Table 8. Request frame objects

Frame object	Name	Bytes/Length	Type/Checksum type	Endianess	Fixed field	Value (Hex)
Constant	Function code	1	Byte	N/A	Yes	N/A
Node address	Node ID	1	Byte	N/A	N/A	N/A
Constant	Index	2	Word (two bytes)	Big-endian	No	Min 0 Max 1000
Constant	Sub index	1	Byte	N/A	No	Min 0 Max 255
Data	Data	2	Byte	N/A	Yes	N/A
Checksum	Checksum	2	CRC	N/A	N/A	N/A

4. In the Frame editor **Response** area, add five **frame objects** with the following settings:

Table 9. Response frame objects

Frame objects	Name	Bytes	Type/Checksum type	Endianness	Fixed field	Value (Hex)
Constant	Function code	1	Byte	N/A	Yes	N/A
Node address	Node ID	1	Byte	N/A	N/A	N/A
Constant	Index	2	Word (two bytes)	N/A	No	Min 0 Max 1000
Constant	Sub index	1	Byte	N/A	No	Min 0 Max 255
Checksum	Checksum	2	CRC	N/A	N/A	N/A

### 11.2.6. Setup Node and Transactions

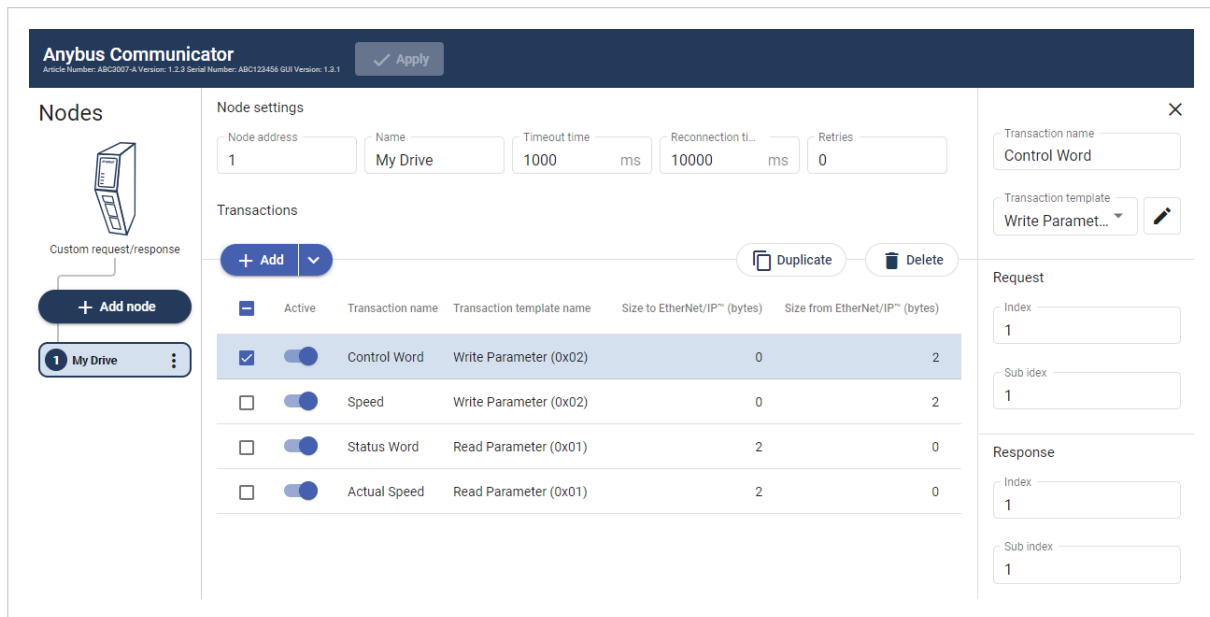

Figure 123. My Drive node with transactions

1. Add a node and select it.
2. In Node settings configure the node with the following settings:

Node settings	Value
Node address	1 My Drive is set up as a node with Node address 1.
Name	My Drive
Timeout time	1000 ms (default)
Reconnecting time	1000 ms (default)
Retries	0 (default)

3. Add four transactions to the My Drive node and configure them with the following settings:

Table 10. My Drive contains the following parameters

Transaction name	Transaction template	Index	Sub index
Control Word	Write Parameter (0x02)	1	1
Speed	Write Parameter (0x02)	1	2
Status Word	Read Parameter (0x01)	2	1
Actual Speed	Read Parameter (0x01)	2	2

### 11.2.7. Check the I/O Configuration

The control word, speed from PROFIBUS to My Drive and status word and actual speed from My Drive to PROFIBUS are mapped as follows in the **I/O configuration** page.

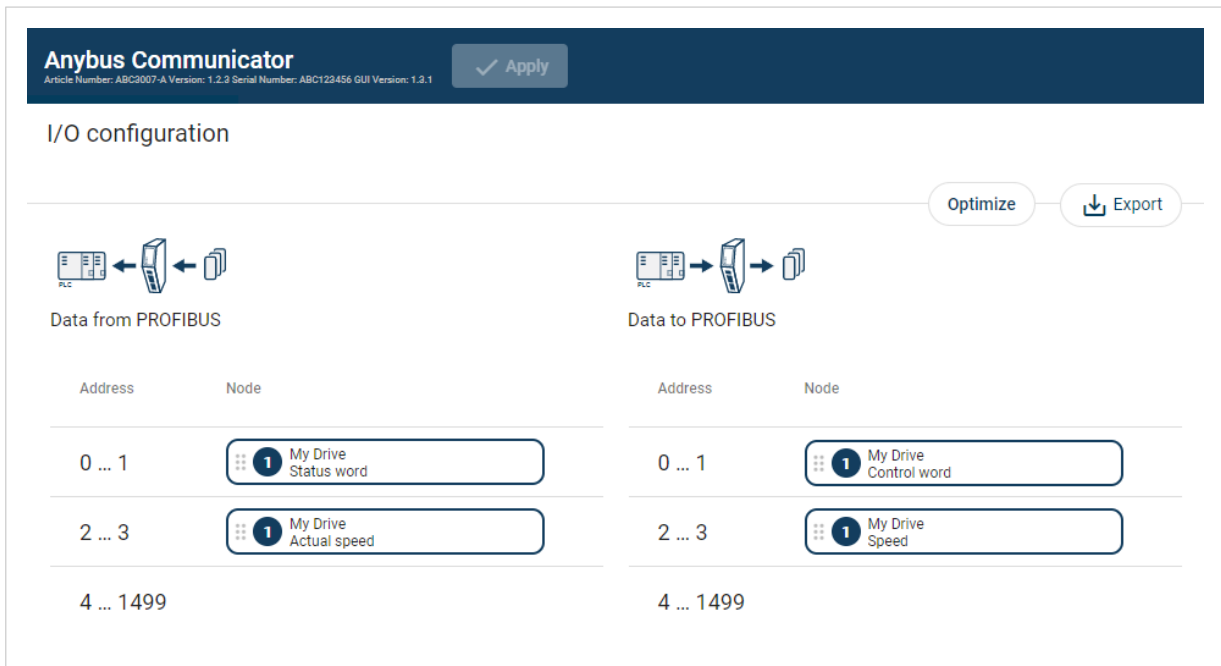

Figure 124. I/O configuration page

Table 11. Control word and speed from PROFIBUS to My Drive

Address	Drive Parameter
0-1	Control Word
2-3	Speed

Table 12. Status word and actual speed from My Drive to PROFIBUS

Address	Drive Parameter
0-1	Control Word
2-3	Speed

## 11.3. Barcode Scanner - Custom Produce/Consume Use Case

### 11.3.1. About the Use Case

The purpose of this use case is to explain how to use the **Custom Produce/Consume** serial protocol.

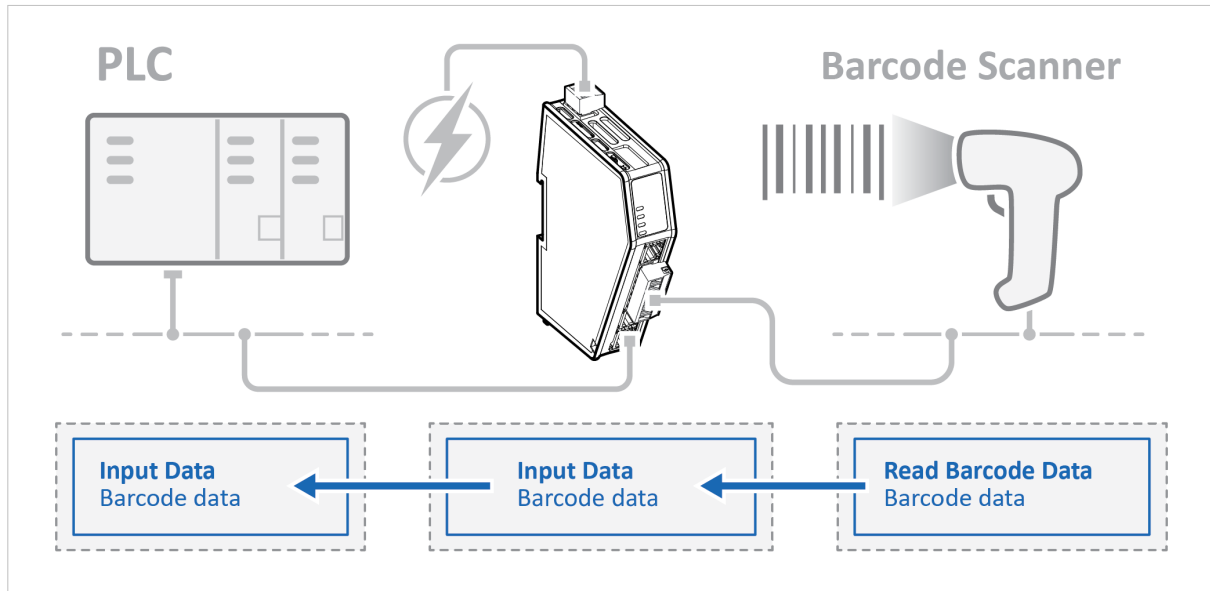

Figure 125. Barcode Scanner - Custom Produce/Consume Use Case

In this use case we use the Communicator to enable data exchange between an Barcode Scanner and a PLC.

The use case describes how to map the communication in the Communicator.

The Barcode Scanner is connected to the serial subnetwork via a custom RS-232 protocol.

The PLC is connected to an PROFIBUS network (high level network).

We use the Custom Produce/Consume serial protocol and create a customized transaction template.

### 11.3.2. Before You Begin

- Connect the Communicator configuration port to your computer.
- Power on the Communicator.
- Ensure that your computer can find the Communicator IP address.
- Enter the Communicator built-in web interface of the.

For more information refer to [Communicator Configuration \(page 43\)](#).

### 11.3.3. Choose Serial Protocol Type

The purpose of this use case is to explain how to use the **Custom Produce/Consume** serial protocol.

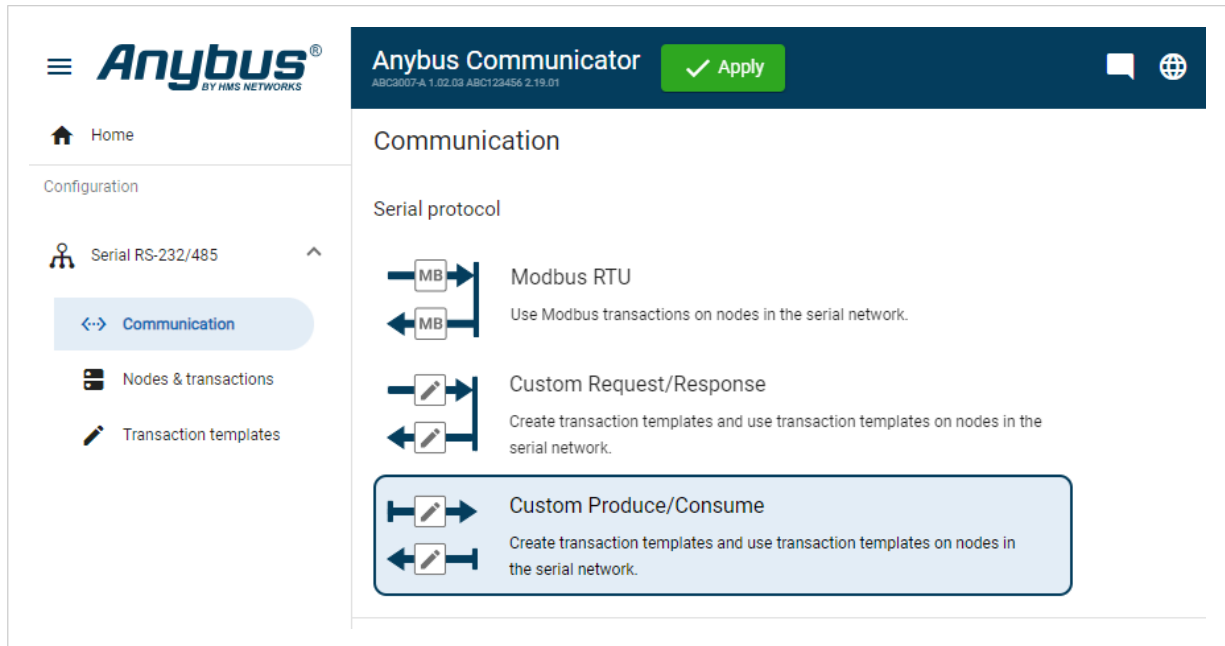

Figure 126. Communication page, **Custom Produce/Consume**

On the **Serial RS232/485** page, select **Custom Produce/Consume**.

### 11.3.4. Setup Serial Communication

Set up the communication between the Communicator and Barcode Scanner.

In the **Serial RS232/485** page, configure the **Communication** settings.

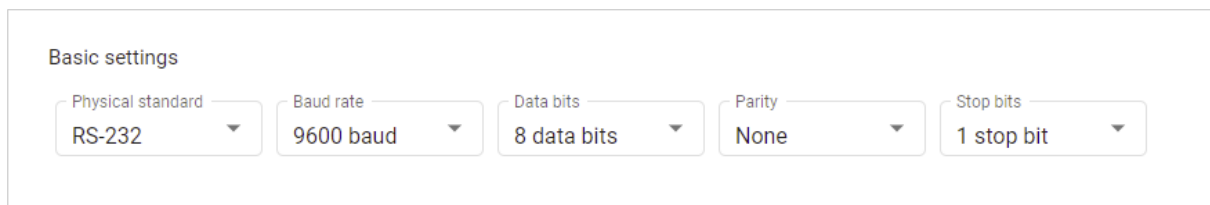

Figure 127. Serial RS232/485, Basic settings

Table 13. Used the following settings:

Frame objects	Value
Physical standard	RS-232
Baud rate	9600 baud
Data bits	8 bits
Parity	None
Stop bits	1 stop bit

## 11.3.5. Create Transaction Templates

### Create Read Barcode Data Parameter

#### Before You Begin

The Communicator reads values delivered from the Barcode Scanner node on to the PLC.

The Barcode Scanner sends data whenever it is available, without any request or handshake from the Communicator.

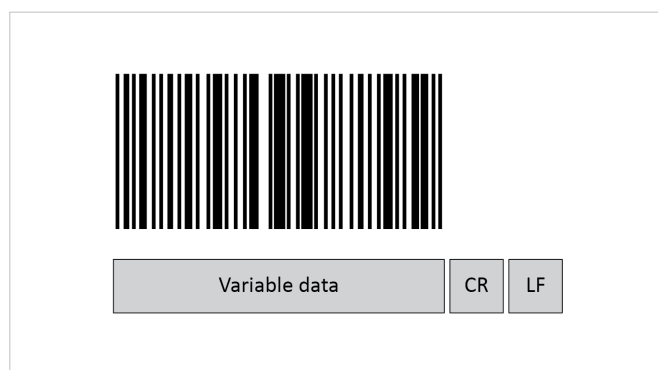

Figure 128. Barcode Variable data, CR and LF

In this example we have added three frame fields for the barcode data transaction:

- One Variable data frame for the length of the barcode.  
We use a fixed value.  
The maximum payload length is 31 (ASCII).
- The Barcode Scanner is configured to append:
  - One Carriage Return character (CR) to the barcode.  
So we create one Constant frame with the Value 13 (ASCII).
  - One Line Feed character (LF) to the barcode.  
So we create one Constant frame with the Value 10 (ASCII).

## Procedure

The screenshot shows the Anybus Communicator web interface. The left sidebar contains navigation options: Home, Configuration (Serial RS-232/485, Communication, Nodes & transactions, Transaction templates), Maintenance (System, Files & firmware), and Troubleshooting (Diagnostics, Support). The main content area is titled 'Anybus Communicator' and includes an 'Apply' button. Below the title, there are 'Transaction templates' and 'Transaction template settings' sections.

**Transaction templates:** A '+ Add' button and a dropdown menu showing 'Read Barcode Data Template'.

**Transaction template settings:**

- Transaction name: Read Barcode Data Template
- Transaction type:  Produce  Consume
- Frame editor: A warning message states 'The template transaction is in use. Changes to the template will directly affect the node attached transactions using it.' Below this are buttons for 'A No...', 'C Co...', 'L Li...', 'D Data', 'V Va...', and 'Cs Ch...'.
- Consume: A table with columns 'Byte offset' and 'Field'.

Byte offset	Field
0 ... 30	<input checked="" type="radio"/> Variable Barcode Data
31	<input checked="" type="radio"/> Constant Carriage Return character (CR) 13
32	<input checked="" type="radio"/> Constant Line Feed character (LF) 10

Figure 129. Read Barcode Data Parameter

1. Add an **Empty consume template** and select it.
2. Name the template **Read Barcode Data**.
3. In the **Frame editor**, add four frame field with the following settings:

Table 14. Consume frame fields

Frame fields	Name	Type	Value	Fixed field	Maximum payload length	Process data delimiter	Subnet delimiter	End pattern
Variable data	Barcode Data	N/A	N/A	Yes, set here	31 bytes	None	None	0
Constant	Carriage Return character (CR)	Byte (1 byte)	13	Yes, set here	N/A	N/A	N/A	N/A
Constant	Line Feed character (LF)	Byte (1 byte)	10	Yes, set here	N/A	N/A	N/A	N/A

### 11.3.6. Setup Node and Transactions

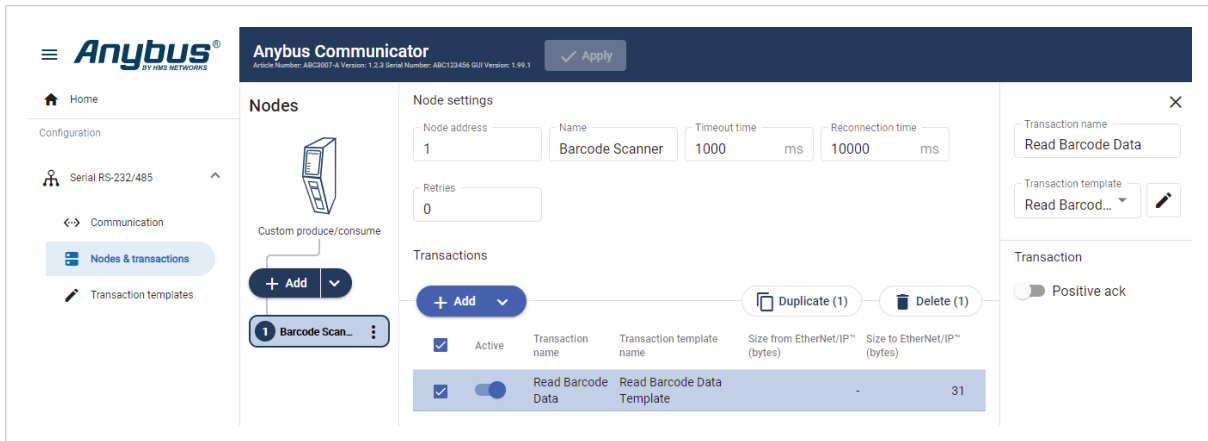

Figure 130. Node settings

1. Add a node and select it.
2. In **Node settings** configure the node with the following settings:

Node settings	Value
Node address	The Barcode Scanner is set up as a node with Node address 1.
Name	Barcode Scanner
Timeout time	1000 ms (default)
Reconnecting time	1000 ms (default)
Retries	0 (default)

3. Add one transactions to the Barcode Scanner node and configure it with the following settings:

Table 15. The Barcode Scanner contains the following parameters

Transaction name	Transaction template
Read Barcode Data	Read Barcode Data Template

### 11.3.7. Check the I/O Configuration

The transactions from the Barcode Scanner is mapped as follows in the **I/O configuration** page.

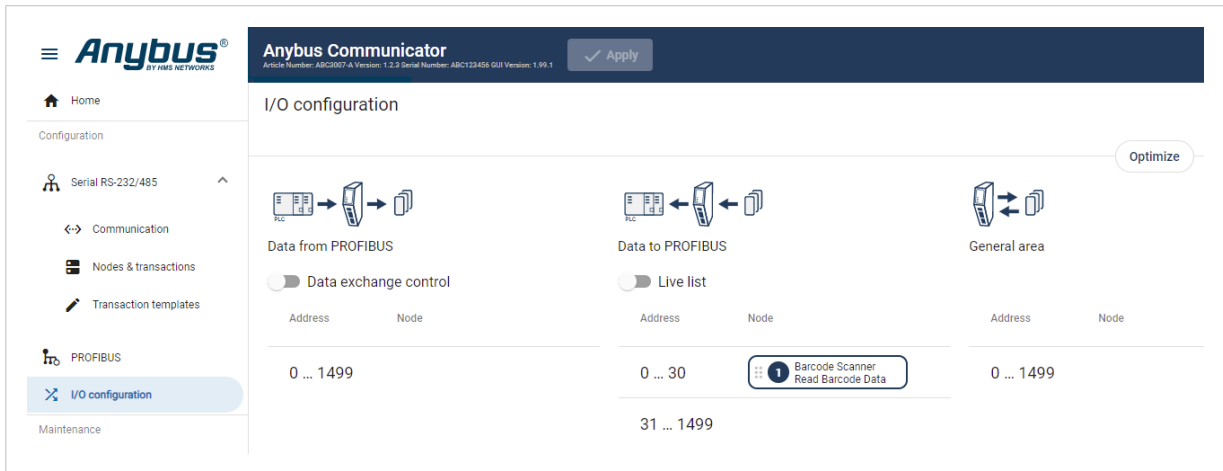

Figure 131. I/O configuration page

Table 16. Status word and actual speed from My Drive to PROFIBUS

Address	Barcode Scanner Parameter
0-31	The variable data, 31 bytes, are forwarded from the Barcode Scanner to the PLC.

## 12. Maintenance

### 12.1. Action on Fatal Error

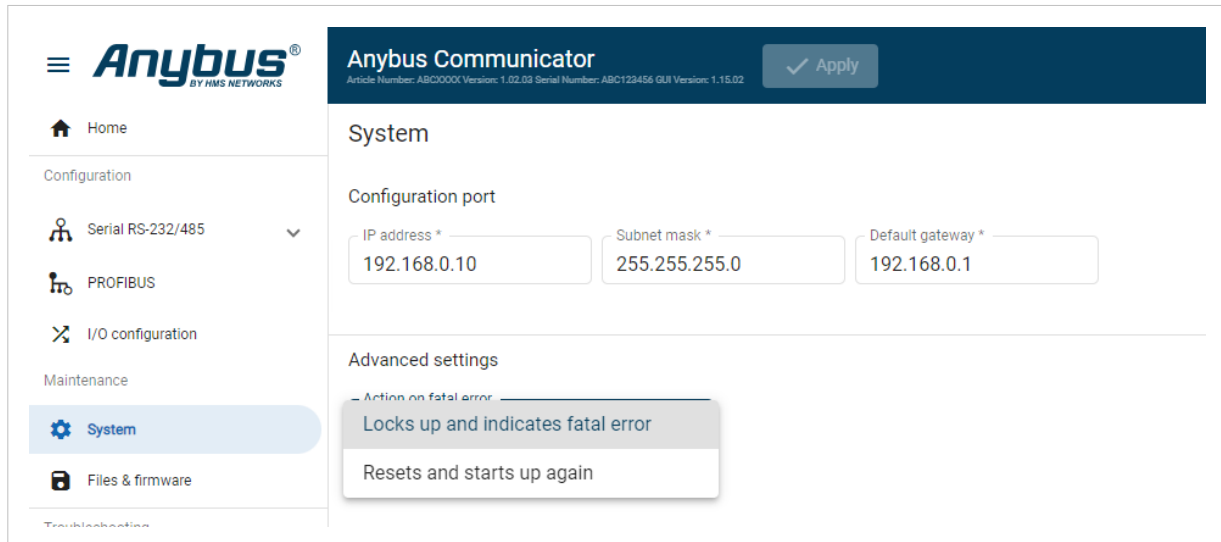

Figure 132. System page, Action on fatal error menu

A fatal error causes the Communicator firmware application to crash in an uncontrolled manner.

You can configure how the Communicator should behave if a fatal error occurs.

In the **Action on fatal error** menu, select one of the following settings:

- **Locks up and indicates fatal error:** Default setting, the Communicator locks up and the LED indicators indicates a fatal error.
- **Resets and starts up again:** The Communicator is rebooted to reset the system and return to normal operation.

## 12.2. Configuration Port IP Settings

On the **System** page you can change the IP address of the Communicator configuration port.

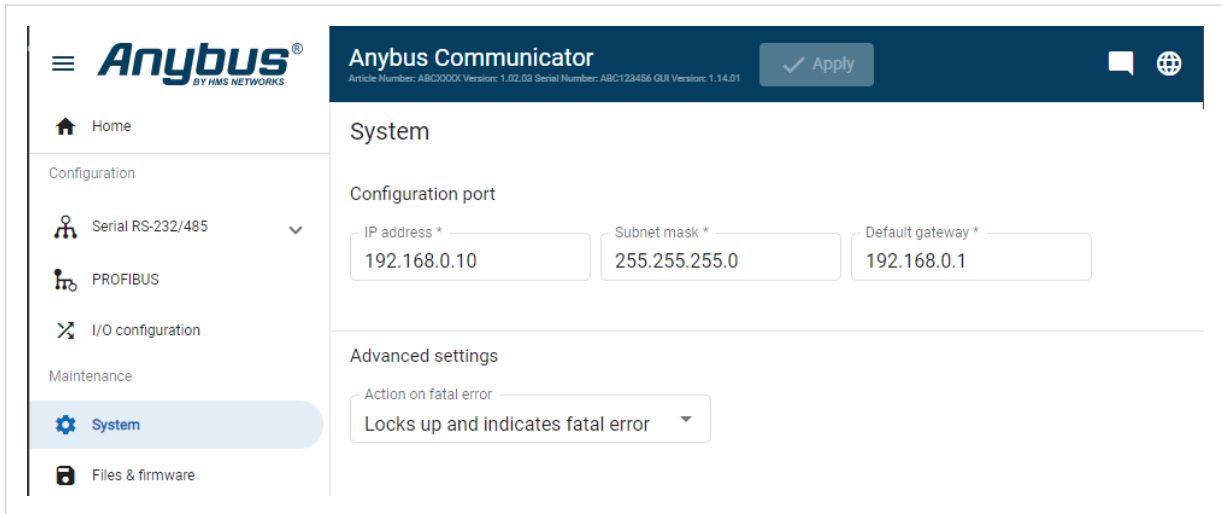

Figure 133. System page, Configuration port settings

### Default Configuration Port IP settings

Setting	Default value
IP address	192.168.0.10
Subnet mask	255.255.255.0
Gateway	There is no default Gateway address.

## 12.3. Configuration File Handling

### 12.3.1. Export Configuration

You can export the current configuration, to import and use the same settings to configure additional Communicator.

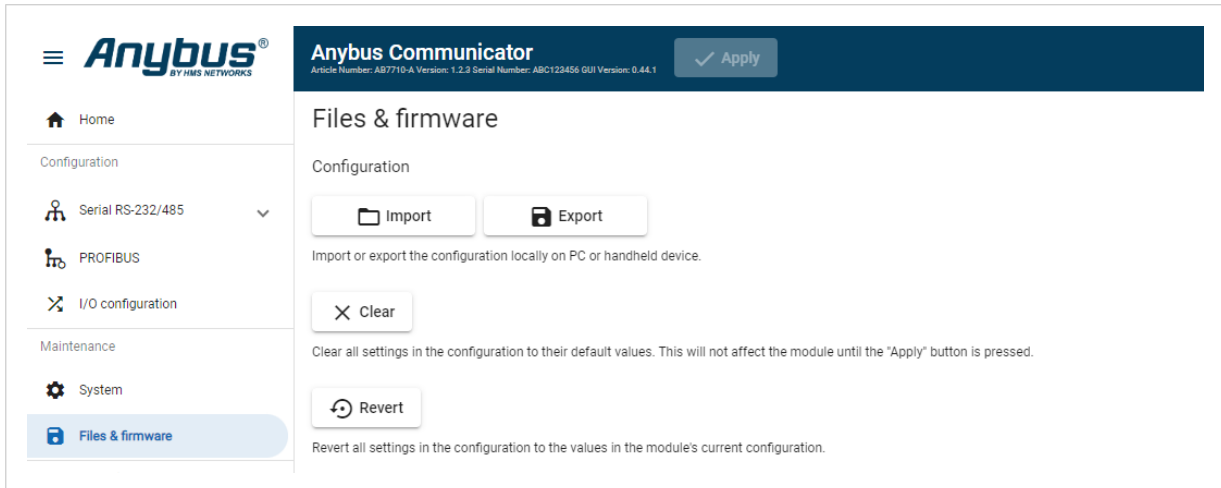

Figure 134. Files & firmware page

To export a configuration file:

In **Files & firmware**, click **Export**.

The configuration settings are stored in a .conf file and downloaded to your PC.

### 12.3.2. Import Configuration

To easily configure multiple Communicator with the same settings, you can import a configuration file.

#### Before You Begin



#### NOTE

Importing a configuration replaces the current applied configuration.

The supported file format is .conf.

#### Procedure

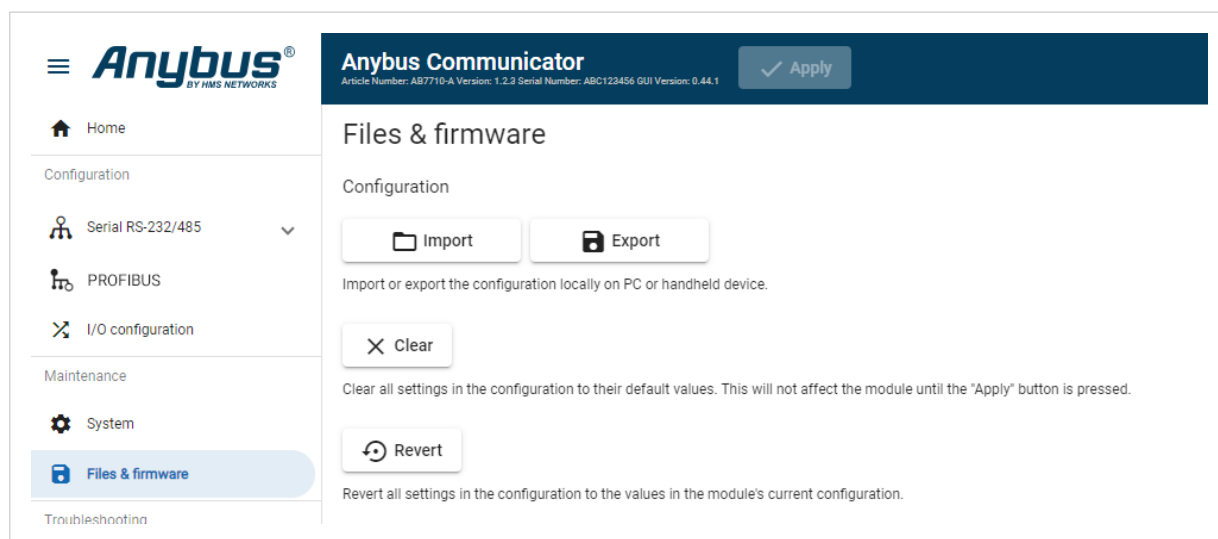

Figure 135. Files & firmware page

Import configuration file:

1. On the **Files & firmware** page, click **Import**.
2. In the Import configuration window, click **Select file (.conf)**.
3. In the Open dialog box, browse to and select the configuration file and click **Open**.
4. In the Import configuration window, click **Import**.
5. In the Communicator address settings window:
  - To import IP settings from the selected configuration file, click **Imported settings**. All configuration settings are imported.
  - To continue using the current IP settings, click **Configured settings**. All configuration settings except the IP settings are imported.
6. The configuration file is parsed.
  - If the configuration is compatible, the settings are imported.
  - If any compatibility mismatches occur, a message about the mismatch appears.
7. To apply the settings, click **Apply** in the web-interface header, and follow the instructions.

## 12.4. Clear and Revert Configuration

You can restore all settings in a configuration to the default settings.

### Procedure

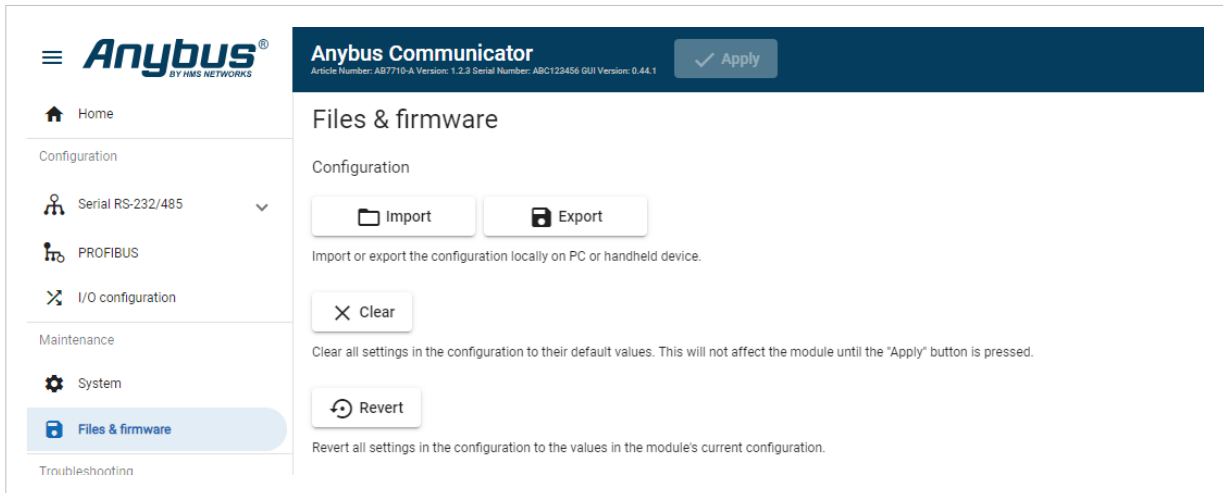

Figure 136. Files & firmware page

#### To Clear the Configuration

When you want to clear a configuration and return to the default settings.

1. On the **Files & firmware** page, click **Clear**.
2. In the Confirm clear window, click **Clear**.
3. To apply the change, click **Apply** in the web-interface header, and follow the instructions.

#### To Revert the Configuration

When you want to remove any configuration made in a current session and re-load the configuration from the gateway.

1. On the Files & firmware page, click **Revert**.
2. In the Confirm revert window, click **Revert**.
3. To apply the change, click **Apply** in the web-interface header, and follow the instructions.

## 12.5. Firmware Management

### 12.5.1. View the Firmware Version

On the **Support** page, you can view the current applied firmware version.



Figure 137. Support page, Product information example

### 12.5.2. Firmware and Configuration Compatibility

#### Compatibility after firmware upgrade

Current configuration is still compatible after upgrading the firmware.

#### Compatibility after firmware downgrade



#### IMPORTANT

Compatibility after a firmware downgrade cannot be guaranteed.

The current configuration may use features not available in the older firmware version.

### 12.5.3. Firmware File Validation

Before the firmware file is imported into the system, the firmware upgrade function performs a validation of the file, to ensure that:

- the firmware is compatible with the Communicator hardware
- the firmware is suited for the product
- the officially HMS software signatures are valid
- that the firmware file is not corrupt or damaged

If the firmware file does not pass the validation, the firmware file is rejected and an error message appear.

## 12.5.4. Update Firmware

### Before You Begin



#### IMPORTANT

To eliminate the risk of interference with plant operation, firmware update is only available when the Communicator is disconnected from the OT networks.

Ensure to disconnect the Communicator from the OT networks.

### Procedure

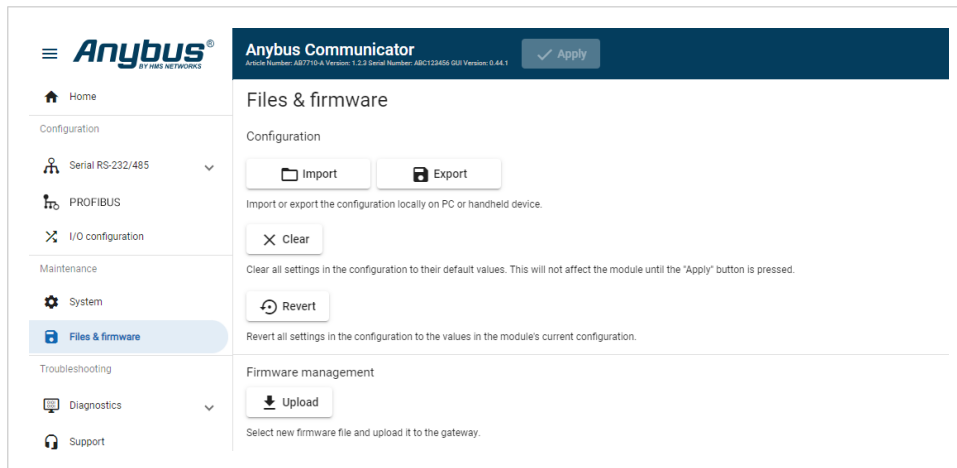

Figure 138. Files & firmware page

To update the firmware:

1. On the **Files & firmware** page, click **Upload**.
2. In the Upload Firmware window, click **Select firmware (.hiff)**.
3. In the Open dialog box, browse to and select the firmware file and click **Open**.
4. To start the firmware upgrade, click **Update firmware**.  
The firmware file is validated and transferred.

### Result

- If the firmware file passes the validation: The firmware is upgraded and then the Communicator automatically reboots, for the upgrade to take effect.
- If the firmware file is rejected: An error message appears.

## 12.6. Change Language

Default language is **English**.

To change the language of the Communicator built-in web interface:

1. In the Communicator built-in web-interface header, click the **Language** icon .

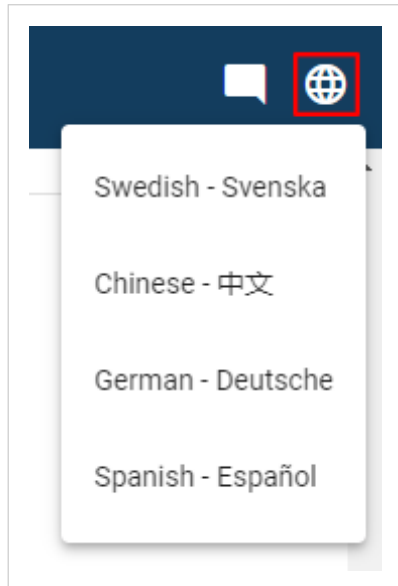

Figure 139. Language menu

2. Select a new language from the list.

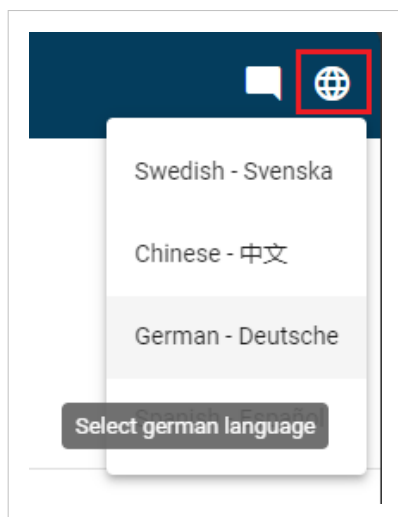

Figure 140. Example: Change language to German

The language change takes effect immediately.

# 13. Troubleshooting

## 13.1. Diagnostics

### 13.1.1. Serial RS-232/485 Data Monitor

On the Serial RS-232/485 page you can monitor how the data flow between the nodes and the gateway changes over time.

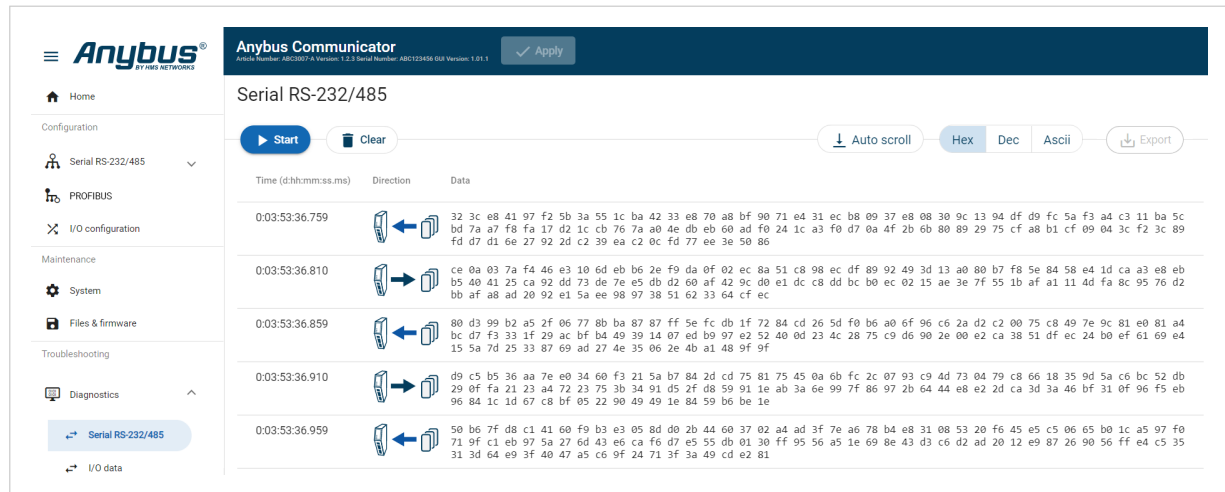

Figure 141. Serial RS-232/485 page

The table can contain at most 10000 messages. When the limit is reached, the oldest messages are discarded when new messages are added.

#### Choose How Data is Displayed

To choose if the data should be displayed in Hexadecimal, Decimal or ASCII, click **Hex**, **Dec** or **Ascii**.

#### Start and Stop Data Flow

To start the data flow, click **Start**.

To end the data flow, click **Stop**.

#### Export Data Flow

To export the data flow, click **Export**.

An Excel file with the data flow is downloaded to your PC.

### 13.1.2. I/O Data

On the **Diagnostics, I/O data** page you can monitor how the data flow between the **Serial RS-232/485** side and the **PROFIBUS** side, including any configured endian conversions.

The screenshot shows the 'I/O data' monitoring page for an Anybus Communicator DPV1S. The interface includes a sidebar with navigation options and a main content area with a 'Start' button and a display format selector (Hex, Dec, Ascii). Two data tables are displayed, showing data flow between the PROFIBUS and the Anybus Communicator DPV1S.

Data from the PROFIBUS to the Anybus Communicator DPV1S		Data from the Anybus Communicator DPV1S to the PROFIBUS	
Address	Data	Address	Data
0 ... 7	00 01 02 03 04 05 06 07	0 ... 7	00 01 02 03 04 05 06 07
8 ... 15	08 09 0a 0b 0c 0d 0e 0f	8 ... 15	08 09 0a 0b 0c 0d 0e 0f
16 ... 23	10 11 12 13 14 15 16 17	16 ... 23	10 11 12 13 14 15 16 17
24 ... 31	18 19 1a 1b 1c 1d 1e 1f	24 ... 31	18 19 1a 1b 1c 1d 1e 1f
32 ... 39	20 21 22 23 24 25 26 27	32 ... 39	20 21 22 23 24 25 26 27
40 ... 47	28 29 2a 2b 2c 2d 2e 2f	40 ... 47	28 29 2a 2b 2c 2d 2e 2f

Figure 142. I/O data

I/O data is updated twice every second.

#### Select how data is displayed

To choose if the data should be displayed in Hexadecimal, Decimal or ASCII, click **Hex**, **Dec** or **Ascii**.

#### Start and Stop Data flow

- To start the data flow, click **Start**.
- To end the data flow, click **Stop**.

### 13.1.3. Event Log

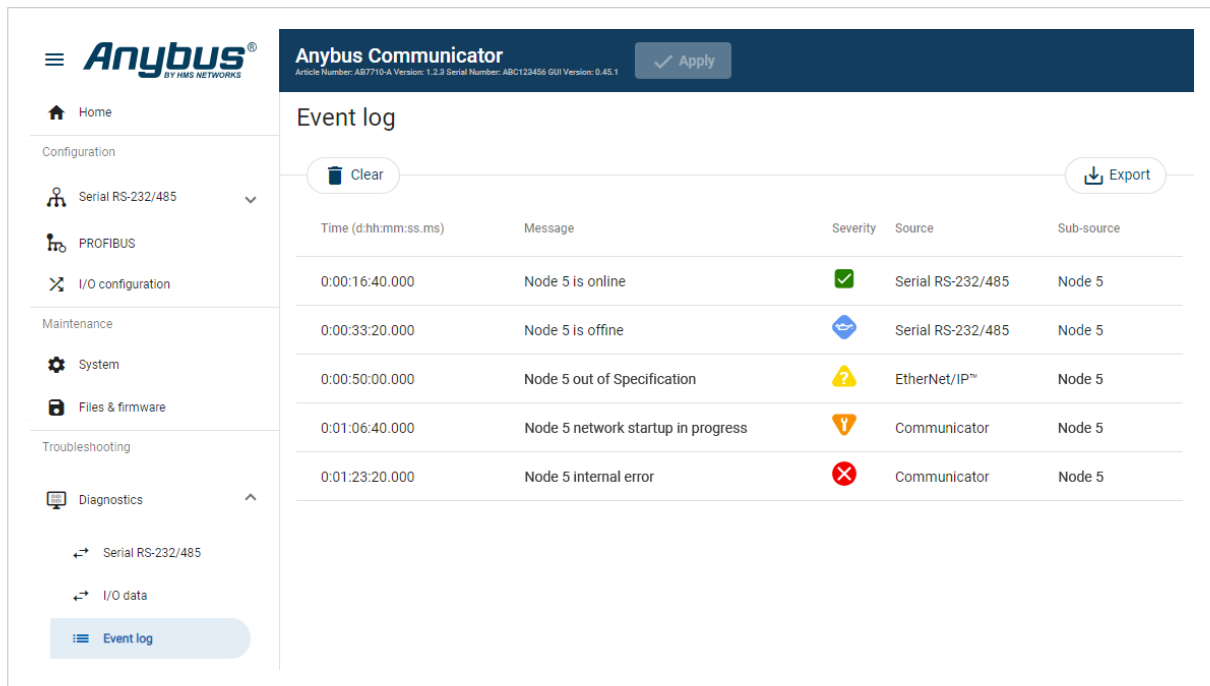

Figure 143. Event log page example

#### How To Analyze the Information

The log follows the FIFO principle, first in and first out. The oldest (first) value is processed first.

Time (d:hh:mm:ss.ms)	The date and time when the event occurred.	
Message	A brief description of the event.	
Severity	The severity of the event occurred. For description of the symbols, see <a href="#">Communicator Status Monitor (page 119)</a> .	
Source	0	Communicator
	1	High level network, PROFIBUS
	2	Subnetwork, Serial RS-232/485
Sub-source	The nodes connected to the subnetwork and the PLC connected to the high level network. If there is a problem with a node the node name is displayed in the Sub-source column.	
	<p>Example 14. Sub-source number</p> <p>If the node name is 5, number 5 is displayed in the Sub-source column.</p>	

To clear the current log, click **Clear**.

### 13.1.4. LED Status

On the Home page, you can remotely monitor the Communicator LED status.

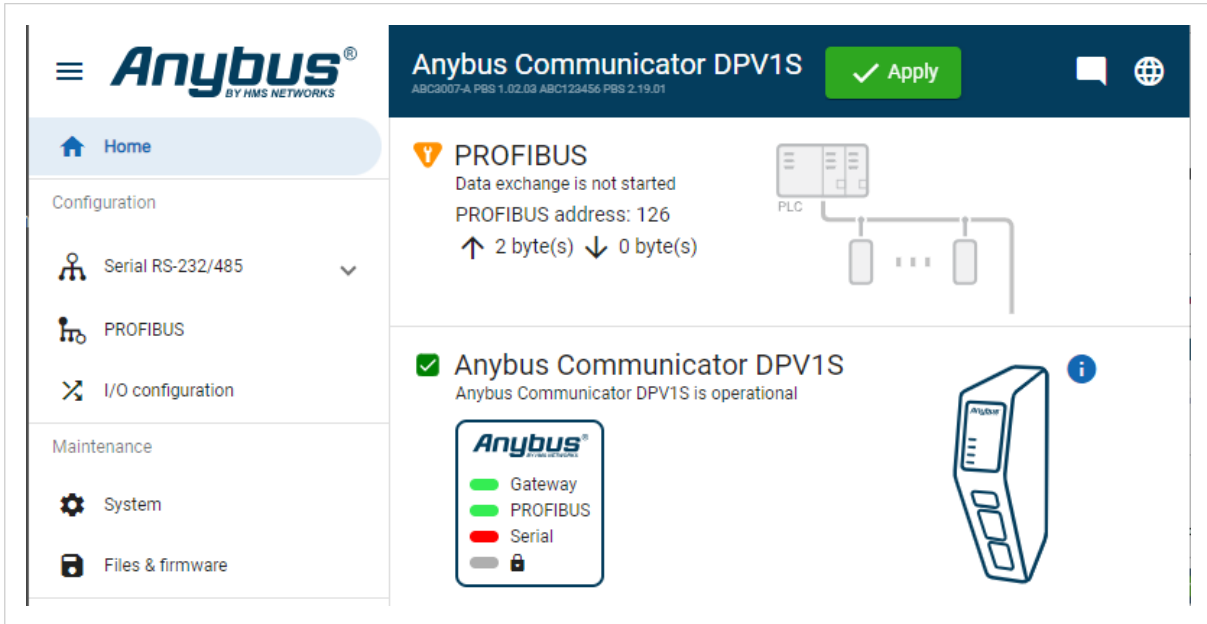

Figure 144. Home page

For information about the LED indication, see [Communicator LED Indicators \(page 121\)](#).

## 13.2. Reset to Factory Settings

### Before You Begin

Factory reset will reset any on site made configuration changes and set the Communicator to the same state as leaving HMS production.

When the Firmware has been updated, factory reset will revert the Communicator configuration to initial state after the update.

### Procedure

To reset the Communicator:

1. Disconnect the Communicator from power.

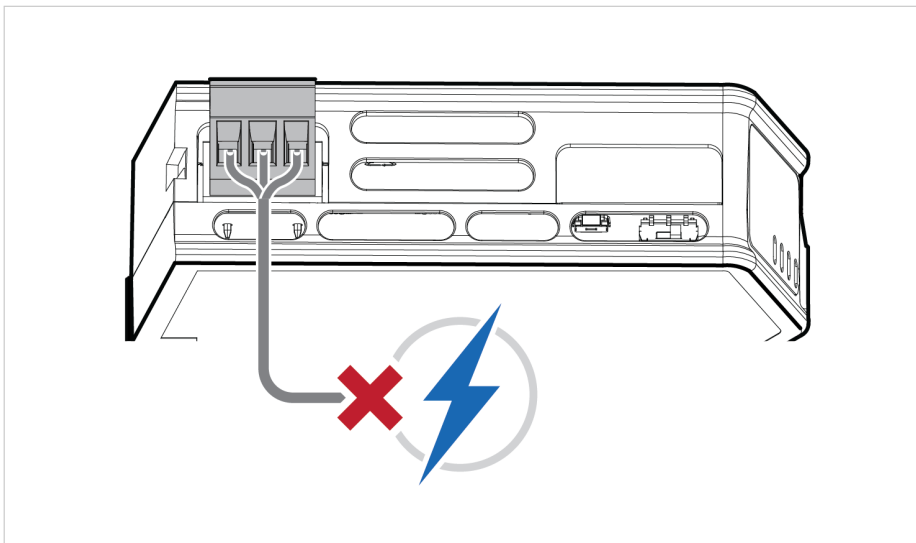

Figure 145. Disconnect power

2. Use a pointed object, such as a ballpoint pen to press and hold the **Reset** button.

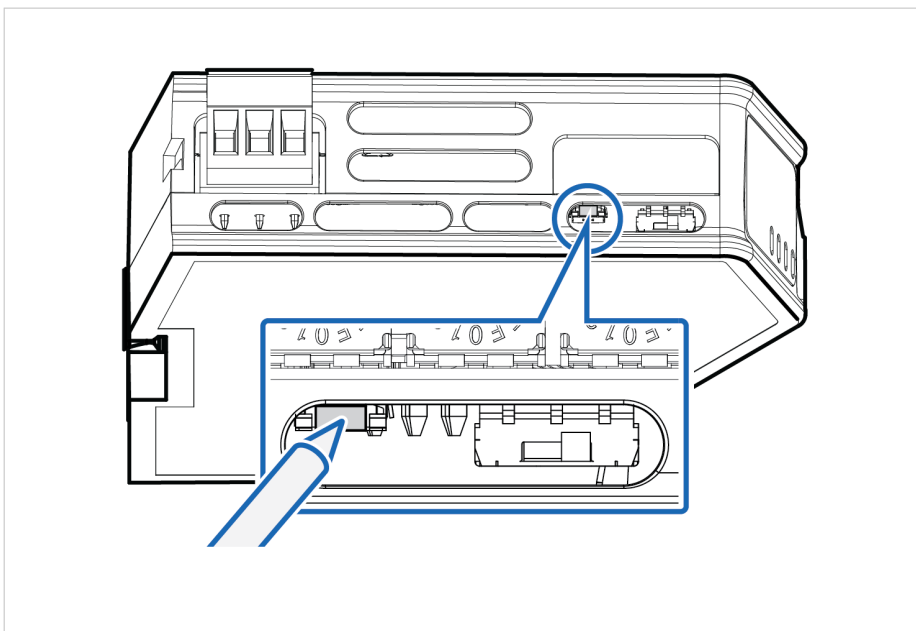

Figure 146. Press and hold **Reset** button

3. While holding the **reset** button, reconnect the Communicator to power.

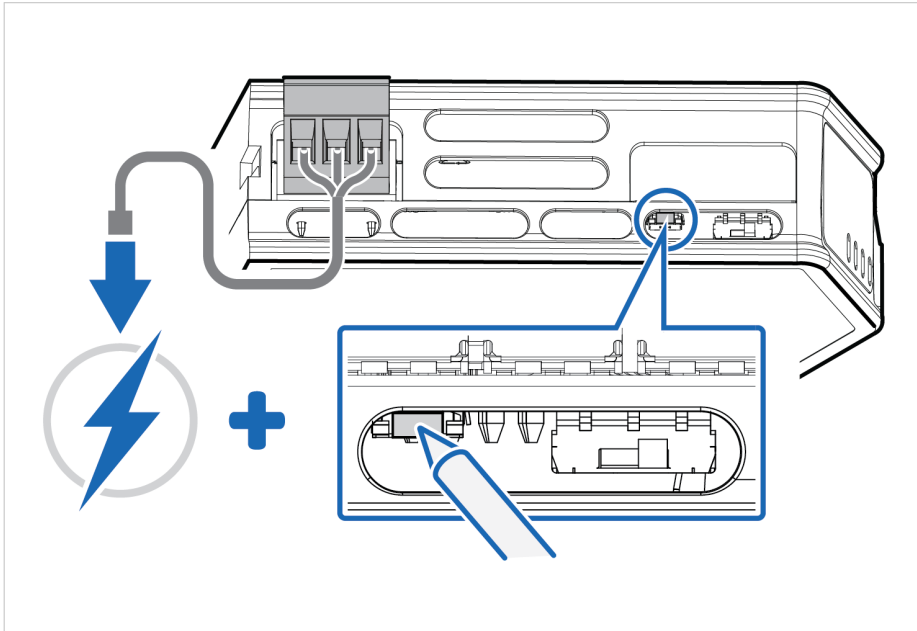

Figure 147. Hold **Reset** button and reconnect power

4. Release the **reset** button.  
The Communicator enters exception state.
5. Reboot the Communicator.

## Result

When the Communicator has successfully rebooted, the Communicator configuration is reset to the factory default configuration or the current configuration after firmware upgrade.

## To Do Next

To ensure that the Communicator built-in web-interface is synchronized.

1. Open the Communicator built-in web interface.
2. Navigate to the **Files & firmware** page and click **Revert**.

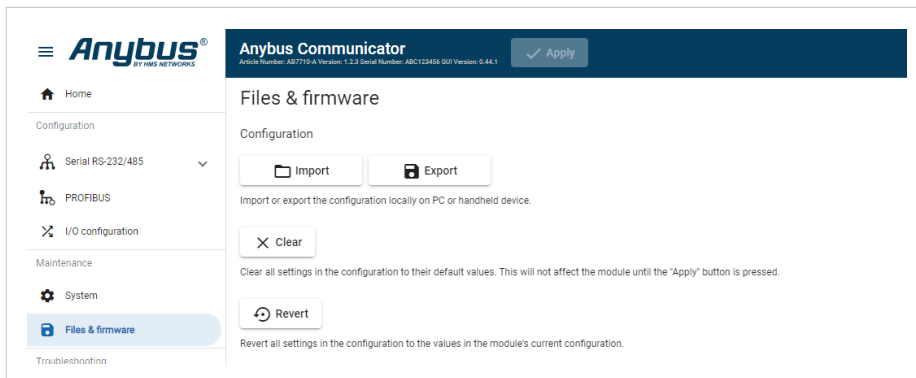

Figure 148. Files & firmware, Revert

## 13.3. Firmware Upgrade Error Management

### Before You Begin

If the firmware update process is interrupted or if the power is lost during the update process, the Communicator goes into fallback mode.

The last working firmware is still available on the flash, but it is not active.

### Procedure

To complete the interrupted firmware update:

1. Disconnect the Communicator from power.

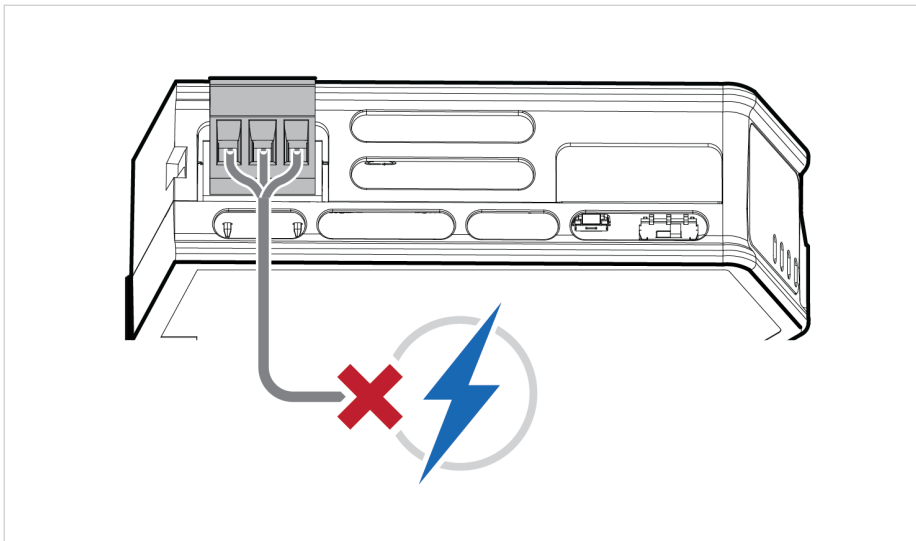

Figure 149. Disconnect power

2. Reconnect the Communicator to power.

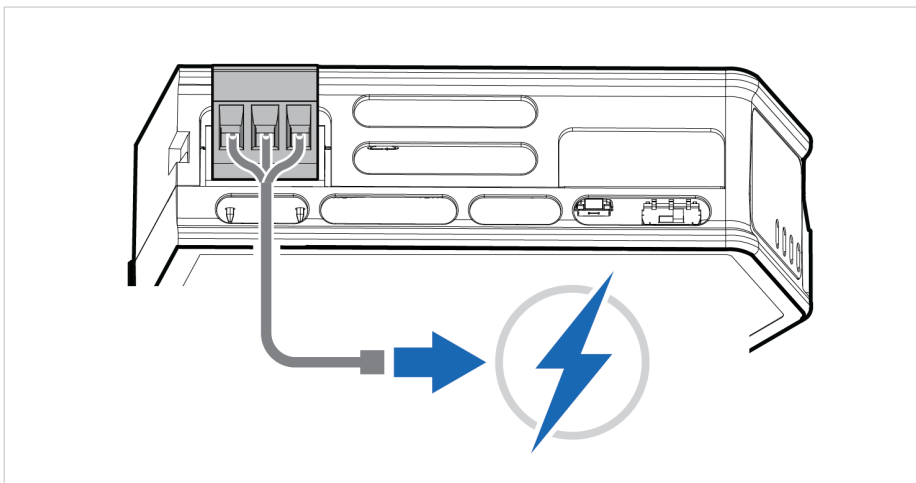

Figure 150. Reconnect power

3. Leave the Communicator for 10 minutes.  
The Gateway status led indicator flashes red and green until the firmware upgrade is completed.

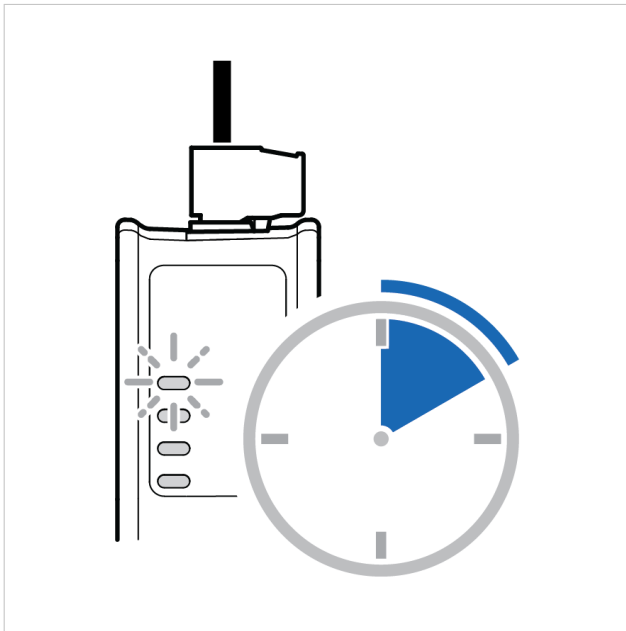

Figure 151. Firmware upgrade LED indication

## Result

The Communicator recover and return to normal operation.

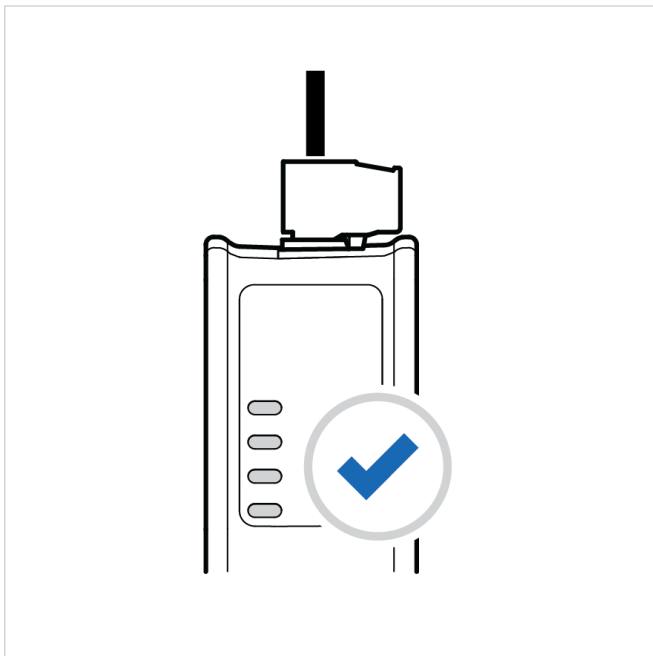

Figure 152. Recover and return to normal operation

## To Do Next

To check LED status, refer to [Communicator LED Indicators \(page 121\)](#).

## 13.4. Support

### 13.4.1. Support Package

The screenshot displays the 'Support' page of the Anybus Communicator interface. The page is divided into several sections:

- Product information:** A table with columns for Product name, Article Number, Serial Number, Version, and GUI Version. The data row shows: Anybus Communicator, ABC3007-A, ABC123456, 1.2.3, 0.45.1.
- Product support website:** Includes a link to the 'Anybus support website' and a QR code with the instruction 'Scan to get to product support website.' Below this, it says 'Get started videos, product documentation, latest firmware and device description files.'
- Product documentation and files:** Contains a button labeled 'EDS file'.
- Support package:** Features a 'Generate' button and a note: 'A support package contains product information that will help us to resolve your case.'
- Contact information:** Includes a 'Find distributor' section with a link to the 'Distributor information portal' and the text 'Contact details for your Anybus distributor.'
- On-line support:** Includes a link to the 'HMS support portal' and the text 'Please generate a support package before you go to the support website so you can attach it to your case.'
- Anybus technical support:** Includes a link to 'Anybus technical support' and the text 'Text is coming very soon! Stand back and observe.'

Figure 153. Support page example

Before you create a ticket for technical support, generate a support package.

The support package contains information about what has occurred and will help the Anybus technical support team resolve the support case as quickly and efficiently as possible.

#### Support Package Content

The information in the support package is available to open and read, the files are not locked or encrypted.

#### Generate Support Package

On the **Support** page, click **Generate**.

A zip file with the support files is downloaded to your PC.

#### Create a Support Ticket

1. On the **Anybus Technical Support** page, navigate to the **Support Center** page and click **HMS Support Portal**.
2. In the **HMS Support Portal**, create a support ticket and upload the support package.

## 14. Technical Data

For complete technical specifications and regulatory compliance information, please visit [www.anybus.com](http://www.anybus.com).

### 14.1. Technical Specifications

Article identification	ABC3000
Configuration connector	RJ45
Communication connector	PROFIBUS DSUB connector
Serial connector	7-pin screw connector
Power connector	3-pin screw connector
Power supply	12-30 VDC, Reverse voltage protection and short circuit protection
Power consumption	Typical: 90 mA @ 24 V (2.2 W) Max: 3 W
Storage temperature	-40 to +85 °C
Operating temperature	-25 to +70 °C
Humidity	EN 60068-2-78: Damp heat, +40°C, 93% humidity for 4 days EN 60068-2-30: Damp heat, +25°C – +55°C, 95% RH, 2 cycles
Vibration	See datasheet
Housing material	Plastic, See datasheet for details
Protection class	IP20
Product weight	150 g
Dimensions	27 x 144 x 98 mm (W x H x D) with connectors included
Mounting	DIN-rail

## 15. End Product Life Cycle

### 15.1. Secure Data Disposal

**IMPORTANT**

To avoid exposure of sensitive data, always perform a factory reset before decommissioning the equipment.

Factory reset will reset any on site made configuration changes and set the Communicator to the same state as leaving HMS production.

See [Reset to Factory Settings \(page 154\)](#).

## 16. Reference Guides

### 16.1. About Input Registers and Holding Registers

Modbus data is most often read and written as registers which are 16-bit pieces of data.

Holding registers and Input registers are both 16-bit registers.

#### Input Registers

Input registers can only be read.

#### Holding Registers

Holding registers can be read or written.

These registers can be used for a variety of things such as inputs, outputs, configuration data, or other requirement for holding data.

### 16.2. Modbus Data Model

Discretes Input	Single bit	Read-Only	Data can be provided by the I/O system.
Coils	Single bit	Read-Write	Data can be alterable by the application program.
Input Registers	16-bit word	Read-Only	Data can be provided by the I/O system
Holding Registers	16-bit word	Read-Write	Data can be alterable by the application program.

Reference: MODBUS Application Protocol Specification V1.1b3, April 26 2012

For more information refer to the Modbus organization website.

### 16.3. Modbus Transactions

Reference: MODBUS Application Protocol Specification V1.1b3, April 26 2012

For more information refer to the Modbus organization website.

Nr	Transaction	Function Code	Description
1	Read Coils	0x01	Read from 1 to 2000 contiguous status of coils in a remote device.
2	Read Discrete Inputs	0x02	Read from 1 to 2000 contiguous status of discrete inputs in a remote device.
3	Read Holding Registers	0x03	Read the contents of a contiguous block of holding registers in a remote device.
4	Read Input Registers	0x04	Read from 1 to 125 contiguous input registers in a remote device.
5	Write Single Coil	0x05	Write a single output to ON or OFF in a remote device.
6	Write Single Register	0x06	Write a single holding register in a remote device.
15	Write Multiple Coils	0x0F	In a sequence of coils, force each coil to either ON or OFF in a remote device.
16	Write Multiple Registers	0x10	Write a block of contiguous registers in a remote device.
22	Mask Write Register	0x16	In a single transaction, modify the contents of a specified holding register using a combination of an AND mask, an OR mask, and the register's current contents. Can be used to set or clear individual bits in the register.
23	Read/Write Multiple Registers	0x17	Performs a combination of one read operation and one write operation. The write operation is performed before the read.

## 16.4. Modbus Exception Codes

Exception Code	Name	Description
01	Illegal Function	The server does not recognize or permit the function code.
02	Illegal Data Address	The data address (register, discrete input or coil number) is not an permitted address for the server. If multiple registers were requested, at least one was not permitted.

Reference: MODBUS Application Protocol Specification V1.1b3, April 26 2012

For more information refer to the Modbus organization website.

## 16.5. ASCII Table

	x0	x1	x2	x3	x4	x5	x6	x7	x8	x9	xA	xB	xC	xD	xE	xF
<b>0x</b>	NUL 0	SOH 1	STX 2	ETX 3	EOT 4	ENQ 5	ACK 6	BEL 7	BS 8	HT 9	LF 10	VT 11	FF 12	CR 13	SO 14	SI 15
<b>1x</b>	DLE 16	DC1 17	DC2 18	DC3 19	DC4 20	NAK 21	SYN 22	ETB 23	CAN 24	EM 25	SUB 26	ESC 27	FS 28	GS 29	RS 30	US 31
<b>2x</b>	(sp) 32	! 33	" 34	# 35	\$ 36	% 37	& 38	' 39	( 40	) 41	* 42	+ 43	, 44	- 45	. 46	/ 47
<b>3x</b>	0 48	1 49	2 50	3 51	4 52	5 53	6 54	7 55	8 56	9 57	: 58	; 59	< 60	= 61	> 62	? 63
<b>4x</b>	@ 64	A 65	B 66	C 67	D 68	E 69	F 70	G 71	H 72	I 73	J 74	K 75	L 76	M 77	N 78	O 79
<b>5x</b>	P 80	Q 81	R 82	S 83	T 84	U 85	V 86	W 87	X 88	Y 89	Z 90	[ 91	\ 92	] 93	^ 94	_ 95
<b>6x</b>	` 96	a 97	b 98	c 99	d 100	e 101	f 102	g 103	h 104	i 105	j 106	k 107	l 108	m 109	n 110	o 111
<b>7x</b>	p 112	q 113	r 114	s 115	t 116	u 117	v 118	w 119	x 120	y 121	z 122	{ 123	 124	} 125	~ 126	DEL 127

## 16.6. RS232/RS485 Electrical Connection

### 16.6.1. RS485 Typical Connection



**IMPORTANT**

The Communicator has a typical RS485 connection and there are no internal terminations.

To ensure signal integrity and prevent signal reflections on the bus, add termination resistors externally at both ends of the RS485 transmission line.

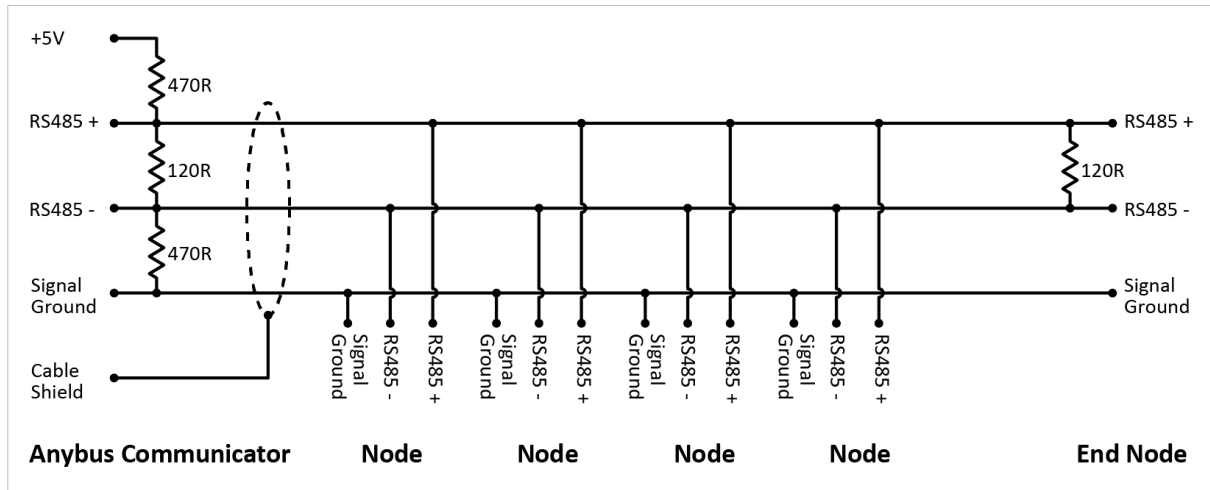

Figure 154. RS485

### 16.6.2. RS232 Typical Connection

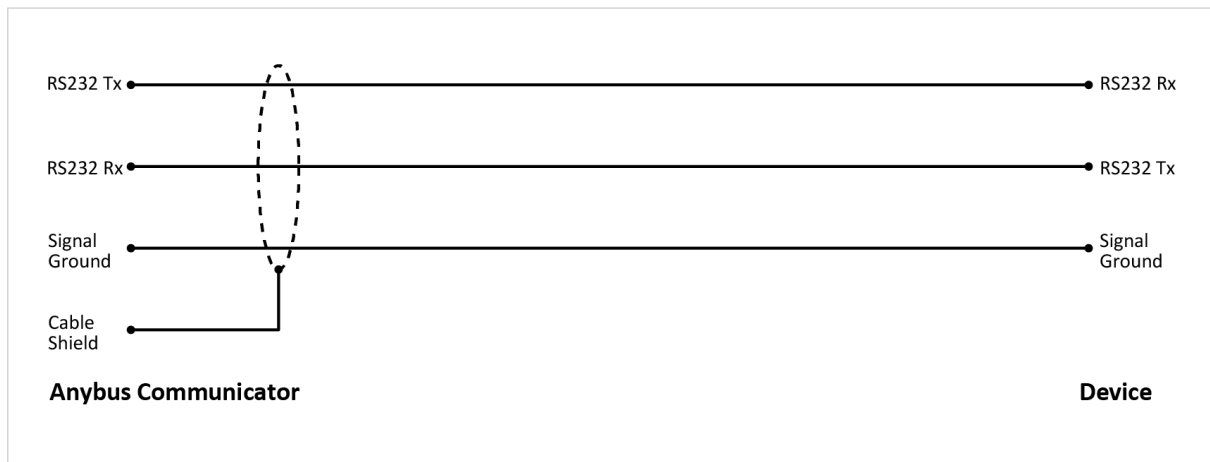

Figure 155. RS232