

Anybus[®] Communicator[™] - PROFINET IO-Device to Modbus TCP Server

USER MANUAL

SCM-1202-197
Version 1.1
Publication date 2023-05-29



Important User Information

Disclaimer

The information in this document is for informational purposes only. Please inform HMS Networks of any inaccuracies or omissions found in this document. HMS Networks disclaims any responsibility or liability for any errors that may appear in this document.

HMS Networks reserves the right to modify its products in line with its policy of continuous product development. The information in this document shall therefore not be construed as a commitment on the part of HMS Networks and is subject to change without notice. HMS Networks makes no commitment to update or keep current the information in this document.

The data, examples and illustrations found in this document are included for illustrative purposes and are only intended to help improve understanding of the functionality and handling of the product. In view of the wide range of possible applications of the product, and because of the many variables and requirements associated with any particular implementation, HMS Networks cannot assume responsibility or liability for actual use based on the data, examples or illustrations included in this document nor for any damages incurred during installation of the product. Those responsible for the use of the product must acquire sufficient knowledge in order to ensure that the product is used correctly in their specific application and that the application meets all performance and safety requirements including any applicable laws, regulations, codes and standards. Further, HMS Networks will under no circumstances assume liability or responsibility for any problems that may arise as a result from the use of undocumented features or functional side effects found outside the documented scope of the product. The effects caused by any direct or indirect use of such aspects of the product are undefined and may include e.g. compatibility issues and stability issues.

Copyright © 2023 HMS Networks

Contact Information

Postal address:
Box 4126
300 04 Halmstad, Sweden

E-Mail: info@hms.se

Table of Contents

1. Preface	1
1.1. About This Document	1
1.2. Document Conventions	1
1.3. Trademarks	2
2. Safety	3
2.1. Intended Use	3
2.2. General Safety	3
3. Preparation	4
3.1. Cabling	4
3.2. System Requirements	4
3.2.1. Supported Operating Systems	4
3.2.2. Supported Web Browsers	4
3.3. Mechanical Tools and Equipment	4
3.4. Support and Resources	4
3.5. HMS Software Applications	5
3.6. Third-Party Software Applications	5
3.7. Software License Information	5
4. About Anybus Communicator	6
4.1. How the Communication Works	6
4.2. How the Data Exchange Works	7
4.3. Data Integrity	7
5. Installation	8
5.1. External Parts	8
5.2. DIN Rail Mounting	9
5.3. Connect to PROFINET Network	10
5.4. Connect to Modbus TCP Network	11
5.5. Connect to Power	12
5.6. Security Switch	13
5.7. Lock the Cables	15
5.8. DIN Rail Demount	16
6. Communicator Configuration	18
6.1. Connect the Communicator	18
6.2. Access the Built-In Web Interface From HMS IPconfig	19
6.3. Access the Built-In Web Interface From a Web Browser	21
6.4. Communicator Built-In Web Interface Overview	22
6.5. PROFINET Settings	23
6.5.1. PROFINET IP Settings	23
6.5.2. PROFINET Station Name Settings	26
6.6. Modbus TCP Settings	26
6.6.1. Modbus TCP IP Settings	26
6.6.2. Timeout Time Settings	28
6.7. I/O Configuration	29
6.8. Configuration Notes	33
6.8.1. Add Configuration Note	33
6.8.2. View and Edit Configuration Notes	35
6.9. Apply Configuration	36
7. PLC Configuration	37

7.1. Export Product GSDML File	37
7.2. Addressing and Register Mapping	38
7.2.1. The Difference Between Address and Register Start	38
7.2.2. To Read and Write Data	38
7.2.3. Data From PROFINET to Modbus TCP Network	39
7.2.4. Data From Modbus TCP Network to PROFINET	39
7.2.5. Idle Mode	40
8. Verify Operation	41
8.1. Communicator Status Monitor	41
8.2. Communicator LED Indicators	43
8.3. Ethernet LED Indicators	45
9. Maintenance	46
9.1. Configuration File Handling	46
9.1.1. Export Configuration	46
9.1.2. Import Configuration	47
9.2. Clear and Revert Configuration	48
9.3. Firmware Management	49
9.3.1. View the Firmware Version	49
9.3.2. Firmware and Configuration Compatibility	49
9.3.3. Firmware File Validation	49
9.3.4. Update Firmware	50
10. Troubleshooting	51
10.1. Diagnostics	51
10.1.1. I/O Data	51
10.1.2. Event Log	52
10.2. Reset to Factory Settings	53
10.3. Firmware Upgrade Error Management	55
10.4. Support	57
10.4.1. Support Package	57
11. Technical Data	58
11.1. Technical Specifications	58

1. Preface

1.1. About This Document

This document describes how to install and configure Anybus® Communicator™.

For additional documentation and software downloads, FAQs, troubleshooting guides and technical support, please visit www.anybus.com/support.

1.2. Document Conventions

Lists

Numbered lists indicate tasks that should be carried out in sequence:

1. First do this
2. Then do this

Bulleted lists are used for:

- Tasks that can be carried out in any order
- Itemized information

User Interaction Elements

User interaction elements (buttons etc.) are indicated with bold text.

Program Code and Scripts

```
Program code and script examples
```

Cross-References and Links

Cross-reference within this document: [Document Conventions \(page 1\)](#)

External link (URL): www.anybus.com

Safety Symbols



DANGER

Instructions that must be followed to avoid an imminently hazardous situation which, if not avoided, will result in death or serious injury.



WARNING

Instructions that must be followed to avoid a potential hazardous situation that, if not avoided, could result in death or serious injury.



CAUTION

Instruction that must be followed to avoid a potential hazardous situation that, if not avoided, could result in minor or moderate injury.



IMPORTANT

Instruction that must be followed to avoid a risk of reduced functionality and/or damage to the equipment, or to avoid a network security risk.

Information Symbols



NOTE

Additional information which may facilitate installation and/or operation.



TIP

Helpful advice and suggestions.

1.3. Trademarks

Anybus® is a registered trademark of HMS Networks.

All other trademarks are the property of their respective holders.

2. Safety

2.1. Intended Use

The intended use of this equipment is as a communication interface and gateway.

The equipment receives and transmits data on various physical layers and connection types.

If this equipment is used in a manner not specified by the manufacturer, the protection provided by the equipment may be impaired.

2.2. General Safety

**CAUTION**

Ensure that the power supply is turned off before connecting it to the equipment.

**CAUTION**

This equipment contains parts that can be damaged by electrostatic discharge (ESD). Use ESD prevention measures to avoid damage.

**CAUTION**

To avoid system damage, the equipment should be connected to ground.

**IMPORTANT**

Using the wrong type of power supply can damage the equipment. Ensure that the power supply is connected properly and of the recommended type.

3. Preparation

3.1. Cabling

Have the following cables available:

- Ethernet cable for configuration
- Ethernet cable x 2 for connecting to the networks
- Power cable

3.2. System Requirements

3.2.1. Supported Operating Systems

Operating System	Description
Windows 7 SP1, 32-bit	Windows 7 32-bit with Service Pack 1
Windows 7 SP1, 64-bit	Windows 7 64-bit with Service Pack 1
Windows 10 64-bit	Windows 10 64-bit
Windows 11 64-bit	Windows 11 64-bit

3.2.2. Supported Web Browsers

The Communicator built-in web interface can be accessed from the following standard web browsers.

- Google Chrome
- Microsoft Edge
- Mozilla Firefox

3.3. Mechanical Tools and Equipment

Have the following tools available:

- Flat-head screwdriver, size 5.5 mm
Needed when removing the Communicator from DIN-rail.

3.4. Support and Resources

For additional documentation and software downloads, FAQs, troubleshooting guides and technical support, please visit www.anybus.com/support.



TIP

Have the product article number available, to search for the product specific support web page. You find the product article number on the product cover.

3.5. HMS Software Applications

Download the software installation files and user documentation from www.anybus.com/support.

HMS IPconfig

Use the software application HMS IPconfig and scan your network to discover and change the Communicator IP address and to access the Communicator built-in web interface.



NOTE

As an alternative, you can set a static IP address within the same IP address range as the Communicator IP address on the computer accessing the Communicator built-in web interface.



NOTE

HMS IPconfig is only available for Windows.

3.6. Third-Party Software Applications

Microsoft Excel

Microsoft Excel, or equivalent software application that supports the Office Open XML Workbook (xlsx) file format. Needed to open and read the **Event log** file.

3.7. Software License Information

For license agreements regarding the third-party software used in the Communicator, refer to the *LICENSE.txt* file(s) included in the Communicator firmware update package zip file.

To download the Communicator firmware update package zip file, please visit www.anybus.com/support.



TIP

Have the product article number available, to search for the product specific support web page. You find the product article number on the product cover.

4. About Anybus Communicator

4.1. How the Communication Works

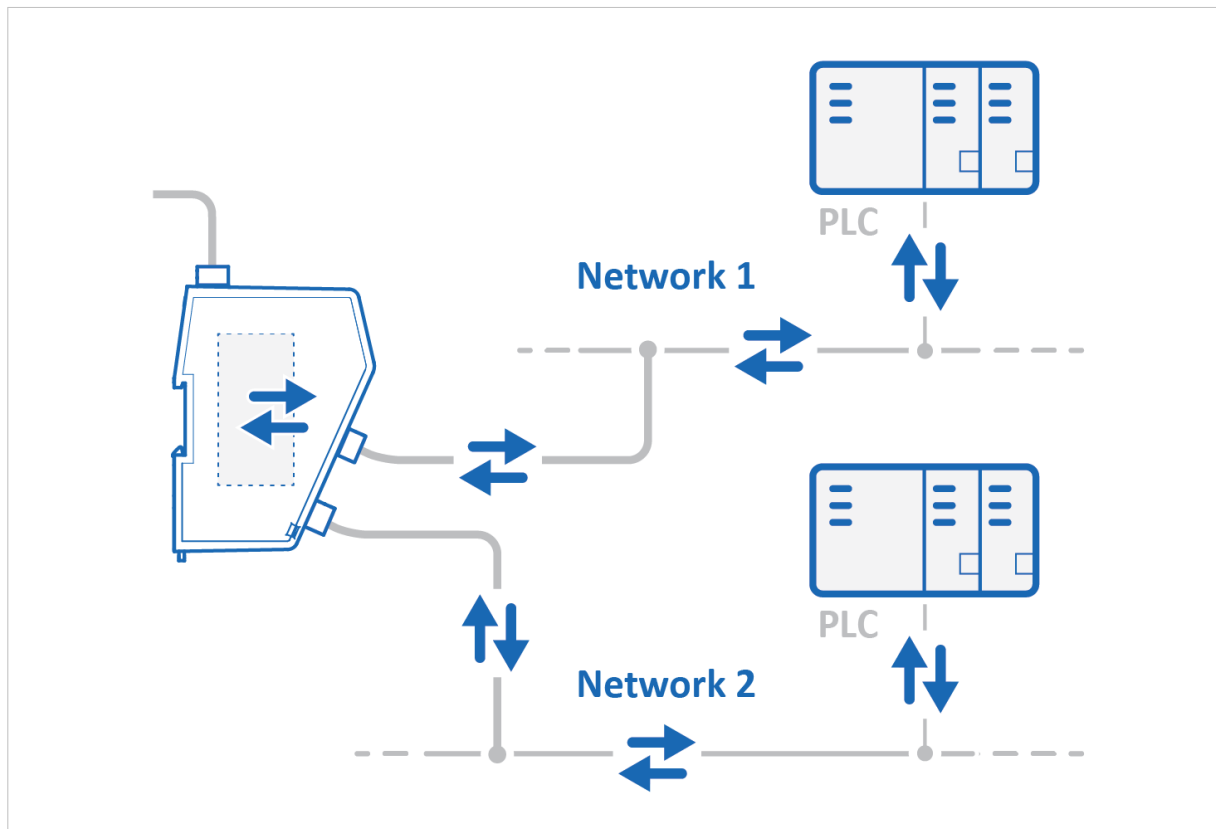

Figure 1. Process data traffic overview

The Communicator enables communication between a Master device connected to a PROFINET network and a Master device connected to a Modbus TCP network.

The Master device can, for example, be a PLC control system or a Gateway.

The Communicator main task is to transfer cyclic I/O data between the two networks.

4.2. How the Data Exchange Works

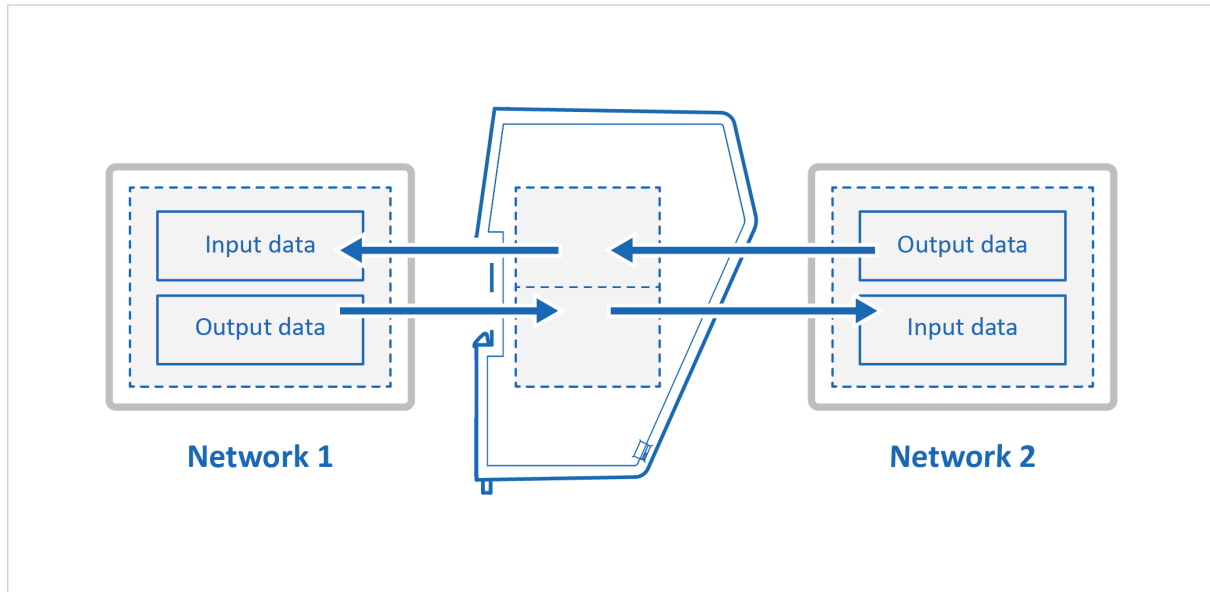

Figure 2. The Communicator internal memory areas

The data exchanged between the Communicator and the PROFINET and the Modbus TCP resides in the Communicator internal memory buffer.

Input Data

This Input data area is read by the Modbus TCP.

Output Data

The Output data area is read/written by the PROFINET.

4.3. Data Integrity

A snapshot of the process data buffer between the PROFINET/Modbus TCP Client and the server interface is used during the operation of executing all the transactions within one cycle.

When the cycle is completed, the process data available on the server interface is updated and a new snapshot is created for the next cycle.

5. Installation

5.1. External Parts

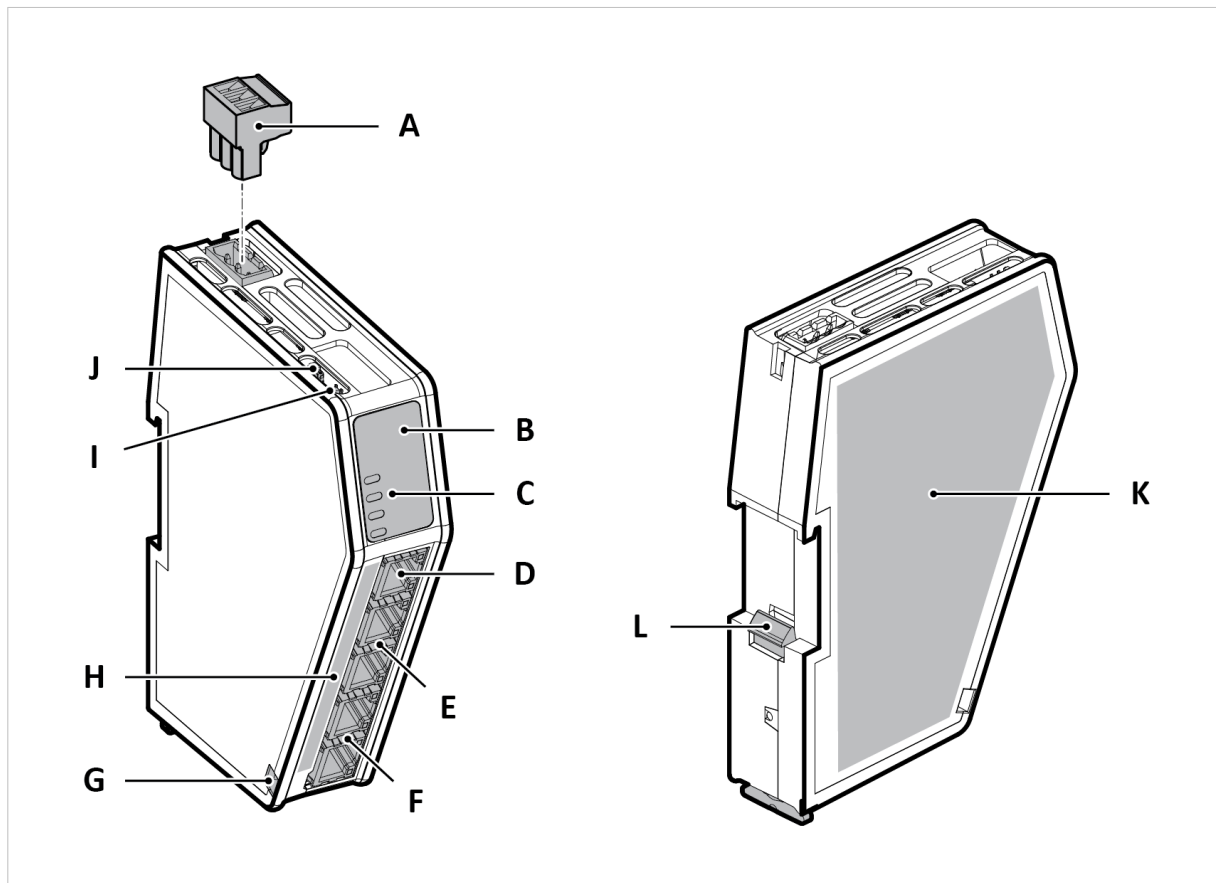

Figure 3. External parts

- | | | |
|-------------------------------|--|--|
| A. Power connector | E. PROFINET port x 2 | I. Security switch |
| B. Label with LED designation | F. Modbus TCP port x 2 | J. Factory reset button |
| C. Status LEDs | G. Cable tie mount | K. Laser engraved label with product information |
| D. Configuration port | H. Laser engraved connectors designation | L. DIN rail locking mechanism |

5.2. DIN Rail Mounting



IMPORTANT

The equipment must be electrically grounded through the DIN rail for EMC compliance. Make sure that the equipment is correctly mounted on the rail and that the rail is properly grounded.

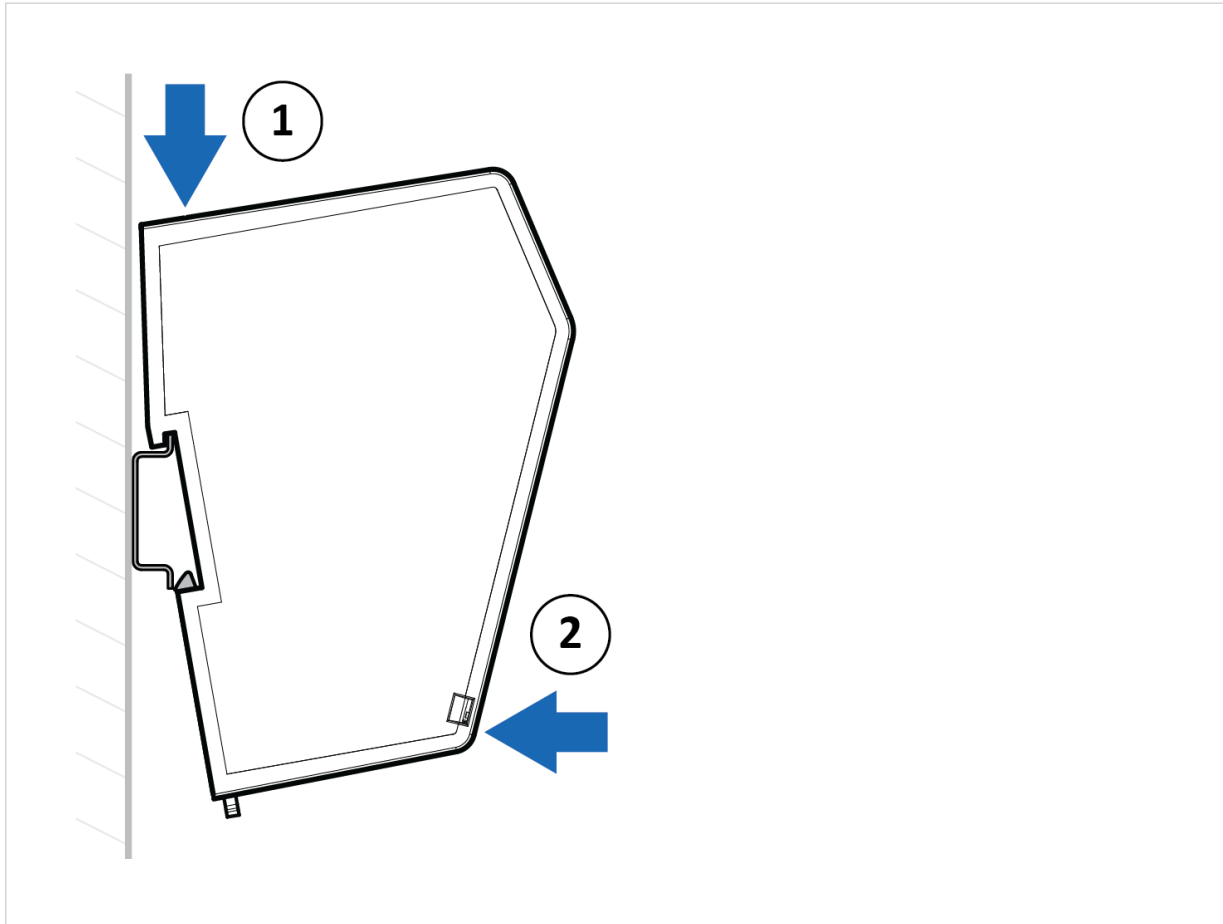

Figure 4. Attach the Communicator on the DIN rail

To attach the Communicator on the DIN rail:

1. Insert the upper end of the DIN rail clip into the DIN rail.
2. Push the bottom of the DIN rail clip into the DIN rail.

5.3. Connect to PROFINET Network

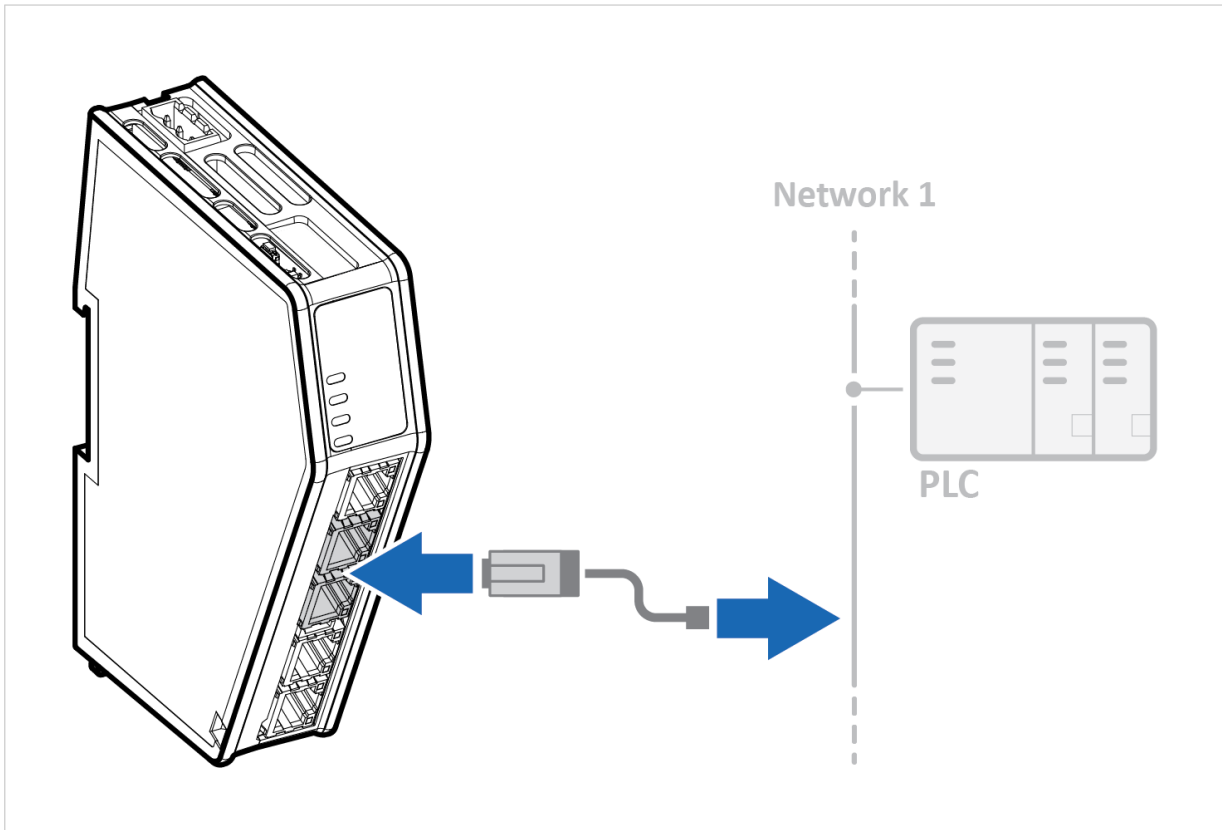
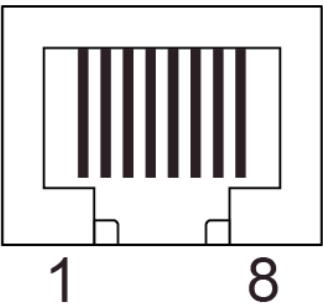

Figure 5. Connect to PROFINET network

1. Connect the Communicator, upper connector, to your PROFINET network.

EtherNet/IP Connector	Pin	Description
	1	TD+
	2	TD-
	3	RD+
	4	Not used
	5	Not used
	6	RD-
	7	Not used
	8	Not used

To Do Next

Connect the Communicator to the Modbus TCP network and to power.

Check LED status, refer to [Communicator LED Indicators](#).

5.4. Connect to Modbus TCP Network

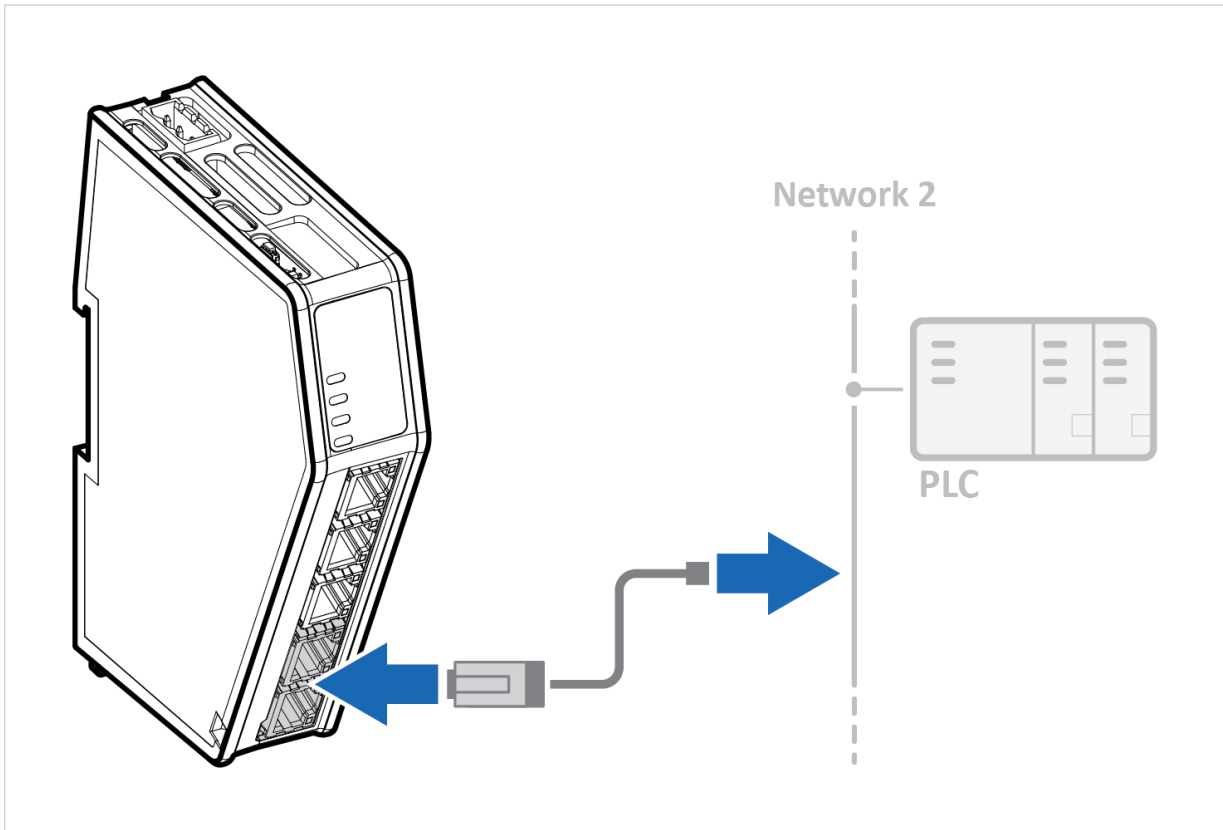
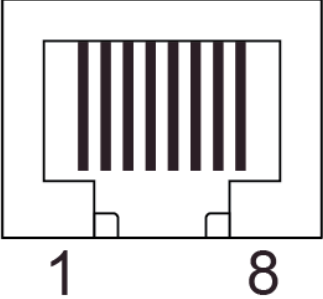

Figure 6. Connect to Modbus TCP network

1. Connect the Communicator, lower connector, to your Modbus TCP network.

EtherNet/IP Connector	Pin	Description
	1	TD+
	2	TD-
	3	RD+
	4	Not used
	5	Not used
	6	RD-
	7	Not used
	8	Not used

To Do Next

Connect the Communicator to the PROFINET network and to power.

Check LED status, refer to [Communicator LED Indicators](#).

5.5. Connect to Power



CAUTION

Ensure that the power supply is turned off before connecting it to the equipment.



IMPORTANT

Using the wrong type of power supply can damage the equipment. Ensure that the power supply is connected properly and of the recommended type.

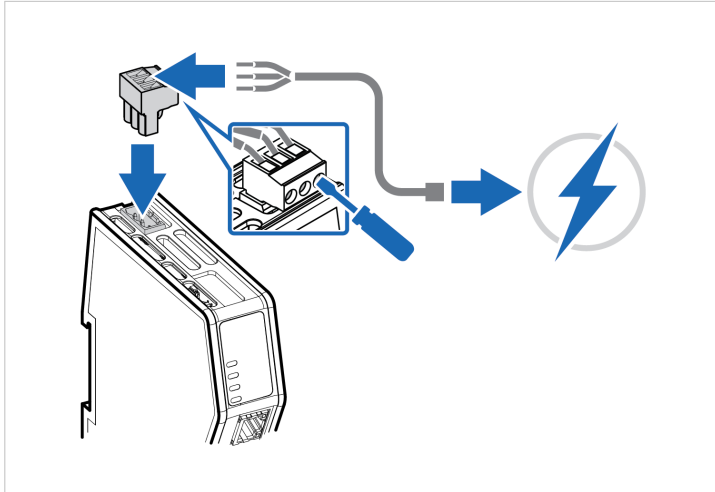

Figure 7. Connect to power

1. Insert the cable wires to the terminal block and tighten the wire clamp screws.

Power port	Pin	Description
	1	12-30 VDC Power Connector
	2	Ground (GND)
	3	Functional Earth (FE)

2. Connect the terminal block to the Communicator.
3. Connect the Communicator to a power supply.
4. Turn on the power supply.

To Do Next

Check LED status, refer to [Communicator LED Indicators](#).

5.6. Security Switch

When the security switch is in its locked position, the Communicator built-in web interface can not be accessed and the Communicator can not be configured using the built-in web interface. Network specific parameters, configured via the PLC is still available.

To Lock and Unlock the Security Switch

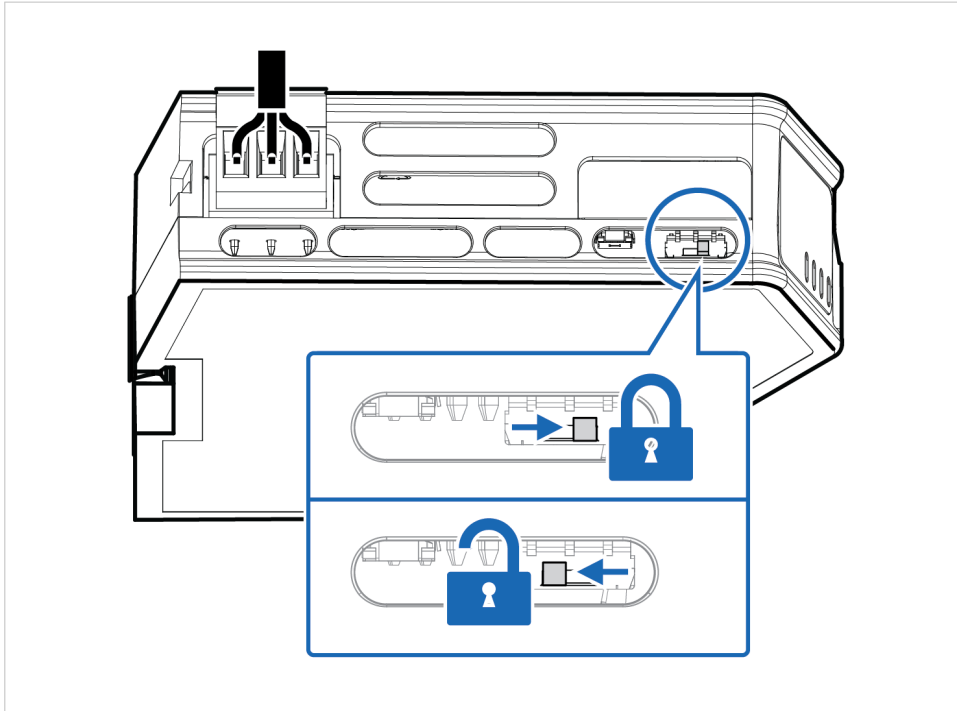

Figure 8. Security switch in locked and unlocked position

Use a pointed object, such as a ballpoint pen.

- To **lock** the security switch, push the toggle towards the **Communicator front**.
- To **unlock** the security switch, push the toggle towards the **Communicator back**.

Security Switch Status LED

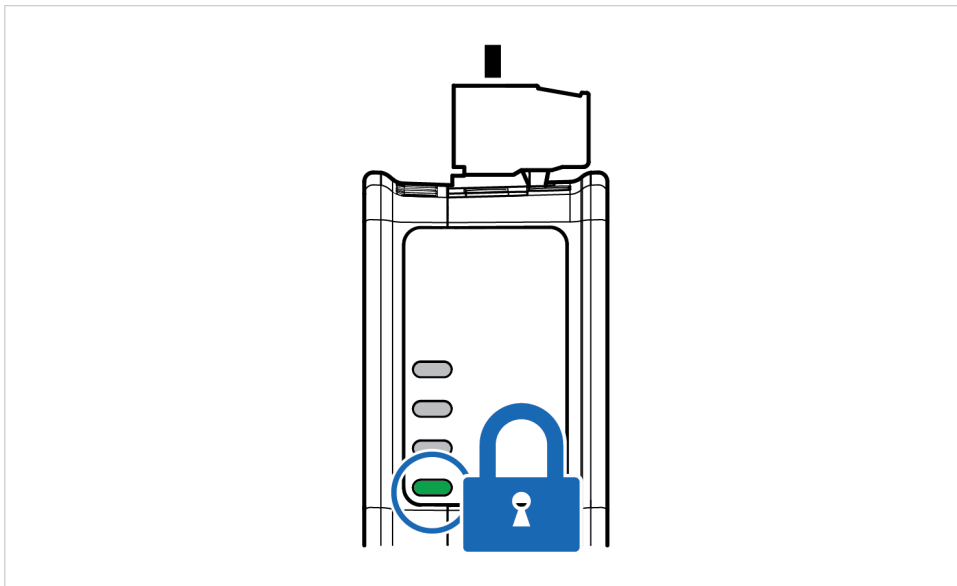

Figure 9. Security switch locked status LED

When the security switch is in its:

- locked position, the security switch status LED turn solid green.
- unlocked position, the security switch status LED is turned off.

5.7. Lock the Cables

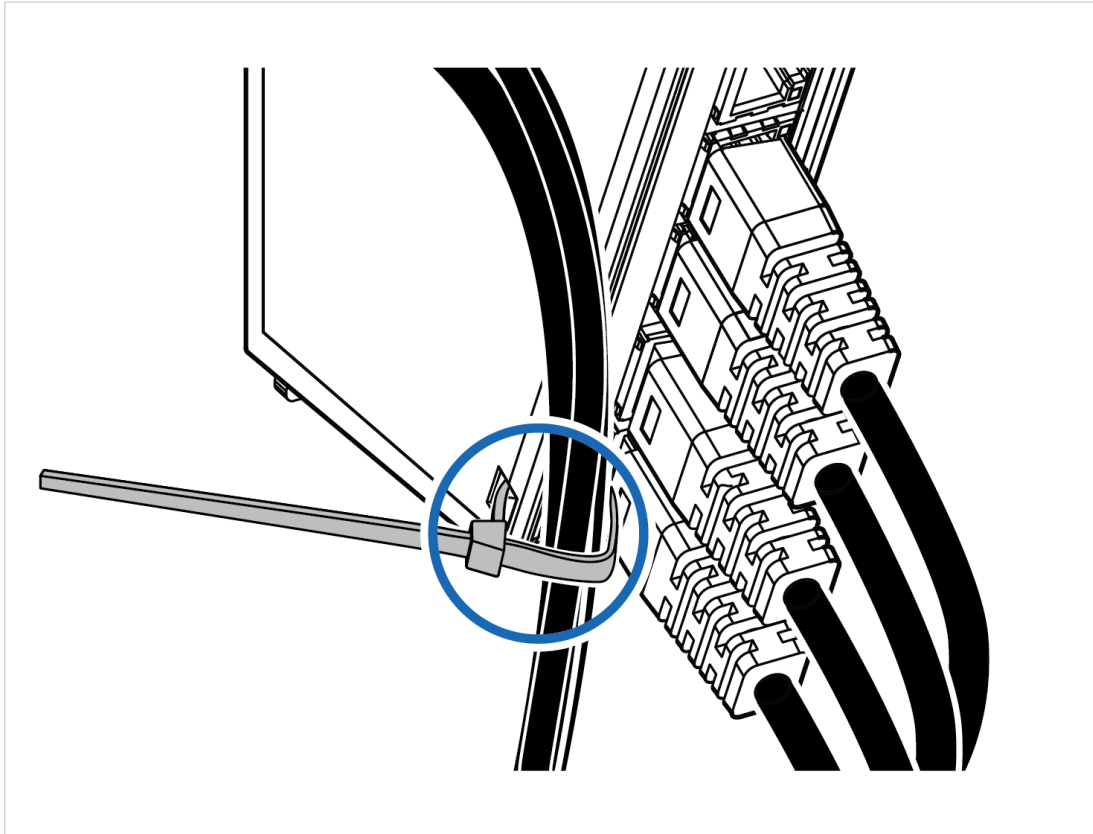

Figure 10. Lock the cables

To strain relieve the cables, place a cable tie in the holder and lock the cables.

5.8. DIN Rail Demount

Before You Begin



IMPORTANT

Be careful when removing the Communicator from the DIN-rail. If not removed properly, the DIN rail locking mechanism and the product cover can break.

Have a flat-blade screwdriver, size 5.5 mm, available.

Procedure

Remove the Communicator from the DIN Rail:

1. Insert the screwdriver into the Communicator DIN rail locking mechanism.
2. To unlock the Communicator DIN rail locking mechanism, turn the screwdriver clockwise.

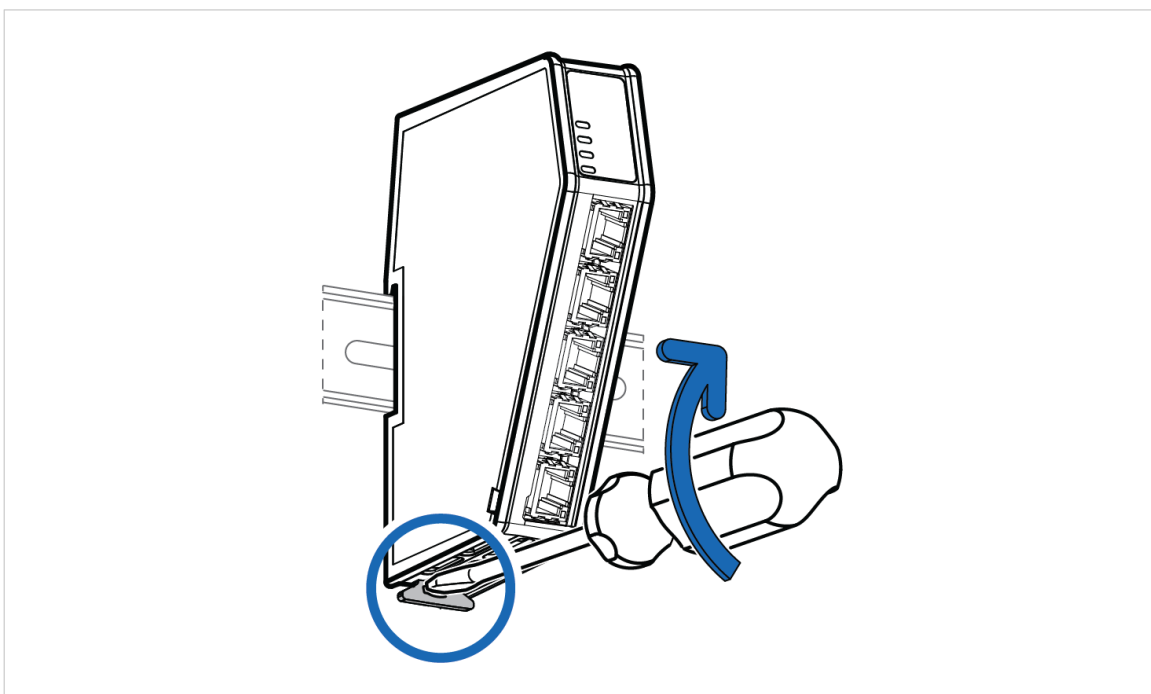

Figure 11. Unlock the Communicator

3. Hold the screwdriver in the DIN rail locking mechanism while you unhook the Communicator from the DIN rail.

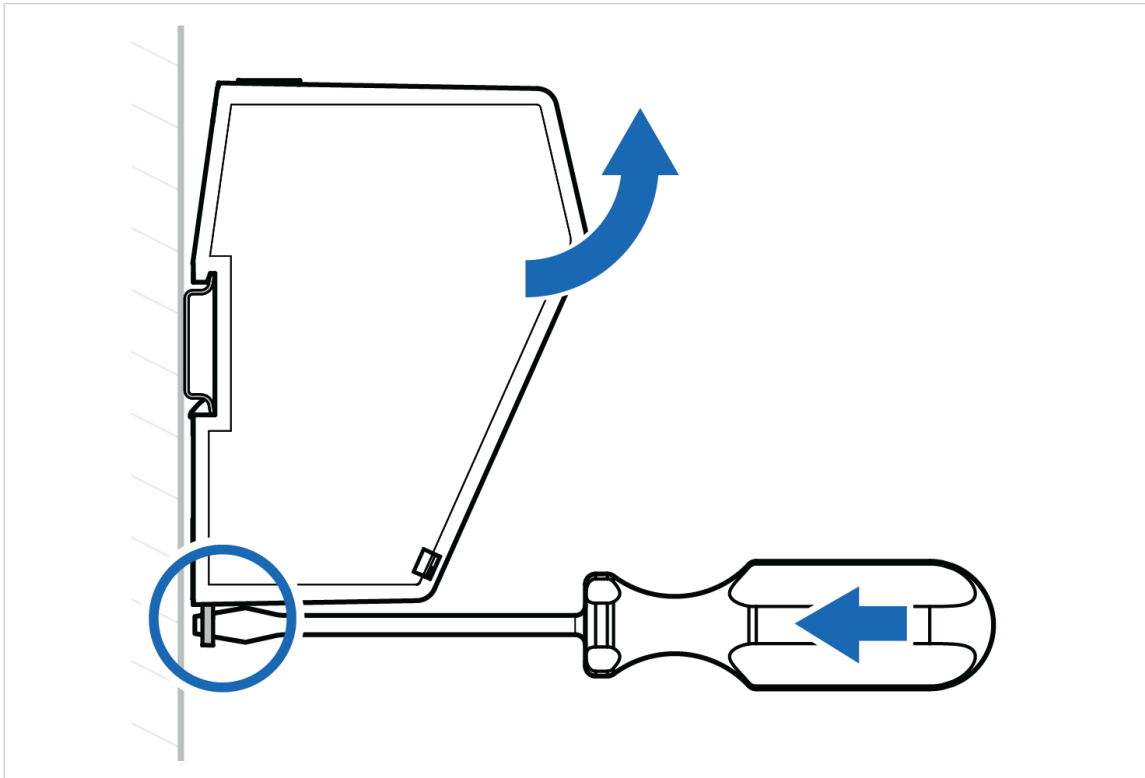

Figure 12. Unhook the Communicator

6. Communicator Configuration

6.1. Connect the Communicator

Procedure

Connect to PROFINET network and Modbus TCP network

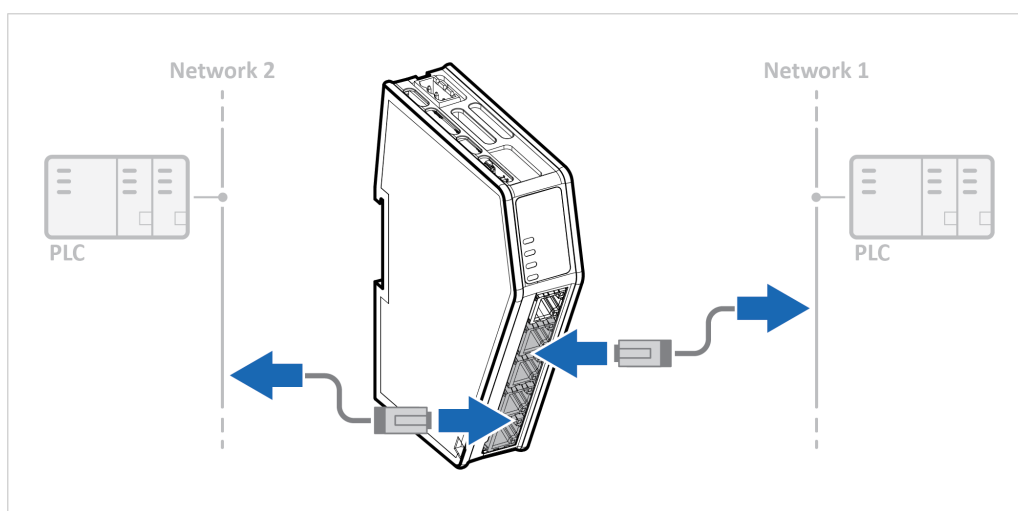

Network 1 = PROFINET Network 2 = Modbus TCP

Connect to PC and Power

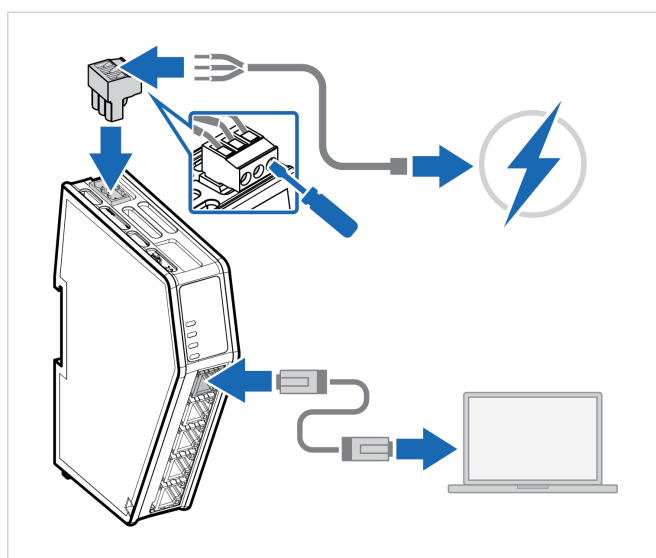

1. Connect an Ethernet cable between the Communicator and your PC.
2. Connect the Communicator to a power supply.

6.2. Access the Built-In Web Interface From HMS IPconfig

Before You Begin

Download the software application HMS IPconfig installation files and user documentation from www.anybus.com/support.



NOTE

The Communicator default IP address is 192.168.0.10.



NOTE

To access the Communicator built-in web interface, ensure that Port 80 TCP is open in your Firewall. This applies to any Firewall between the web browser and the gateway.



NOTE

To access the Communicator built-in web interface from HMS IPconfig, ensure that Port 3250 UDP is open in your PC Windows Firewall.



NOTE

Ensure that the security switch is unlocked. HMS IPconfig cannot configure the Communicator if the security switch is locked.

Procedure

1. Install HMS IPconfig on your PC.
2. Open HMS IPconfig.

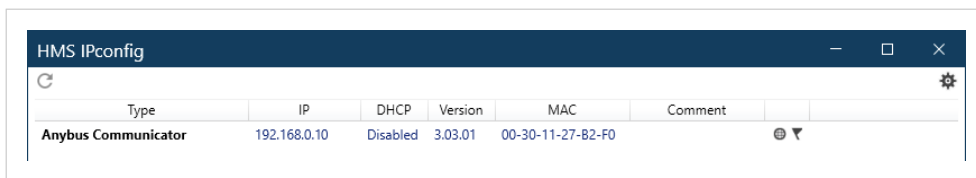

- HMS IPconfig automatically starts scanning for compatible and active HMS devices.
 - Found HMS devices are added to the device list.
3. To open the settings pane, click on the Communicator in the device list.
 4. Change the Communicator configuration port IP address to one within the same IP address range as your PC.

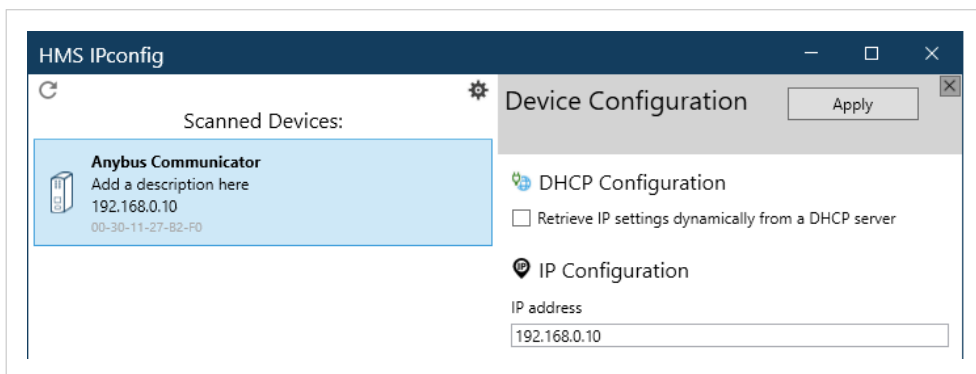

5. To open the **Open web page** built-in web interface, click Communicator.

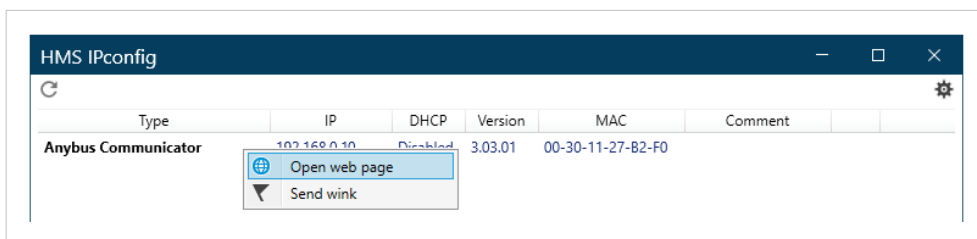

Result

You are redirected to the Communicator built-in web interface Home page.

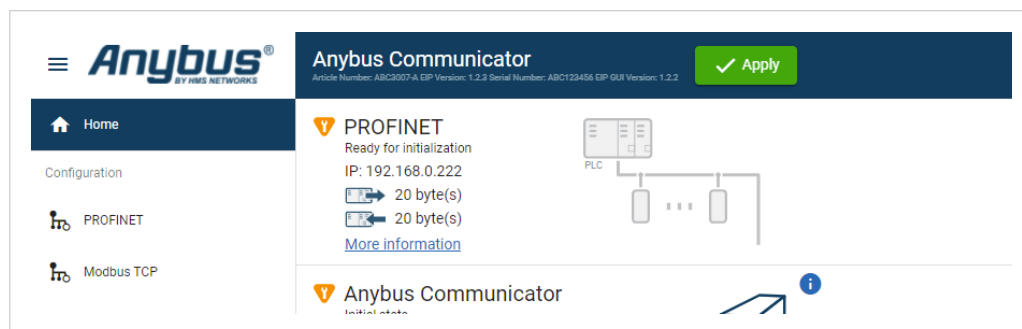

6.3. Access the Built-In Web Interface From a Web Browser

Before You Begin



NOTE

The Communicator configuration port default IP address is 192.168.0.10.



NOTE

To access the Communicator built-in web interface, ensure that Port 80 TCP is open in your Firewall. This applies to any Firewall between the web browser and the gateway.



NOTE

When you change to a static IP address on your computer, internet access may be lost.

Procedure

1. On the PC accessing the Communicator built-in web interface, set a static IP address within the same IP address range as the Communicator IP address.



2. Open a web browser.
3. Click to select the **Address bar** and enter the Communicator IP address.



4. To open the built-in web interface Home page, press **Enter**.

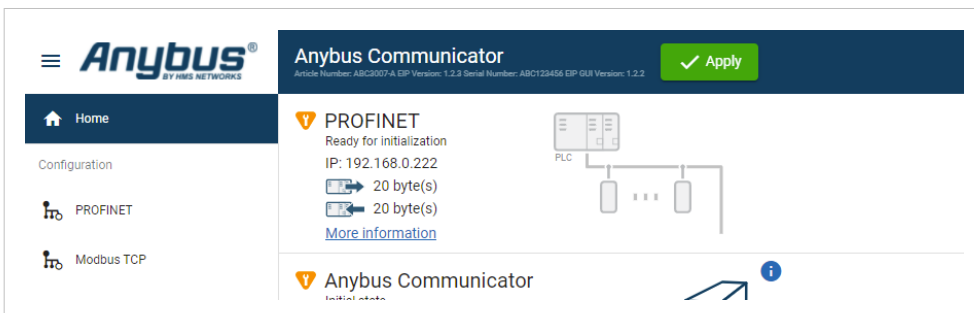

6.4. Communicator Built-In Web Interface Overview

Use the Communicator built-in web interface to configure, maintain and troubleshoot the Communicator.

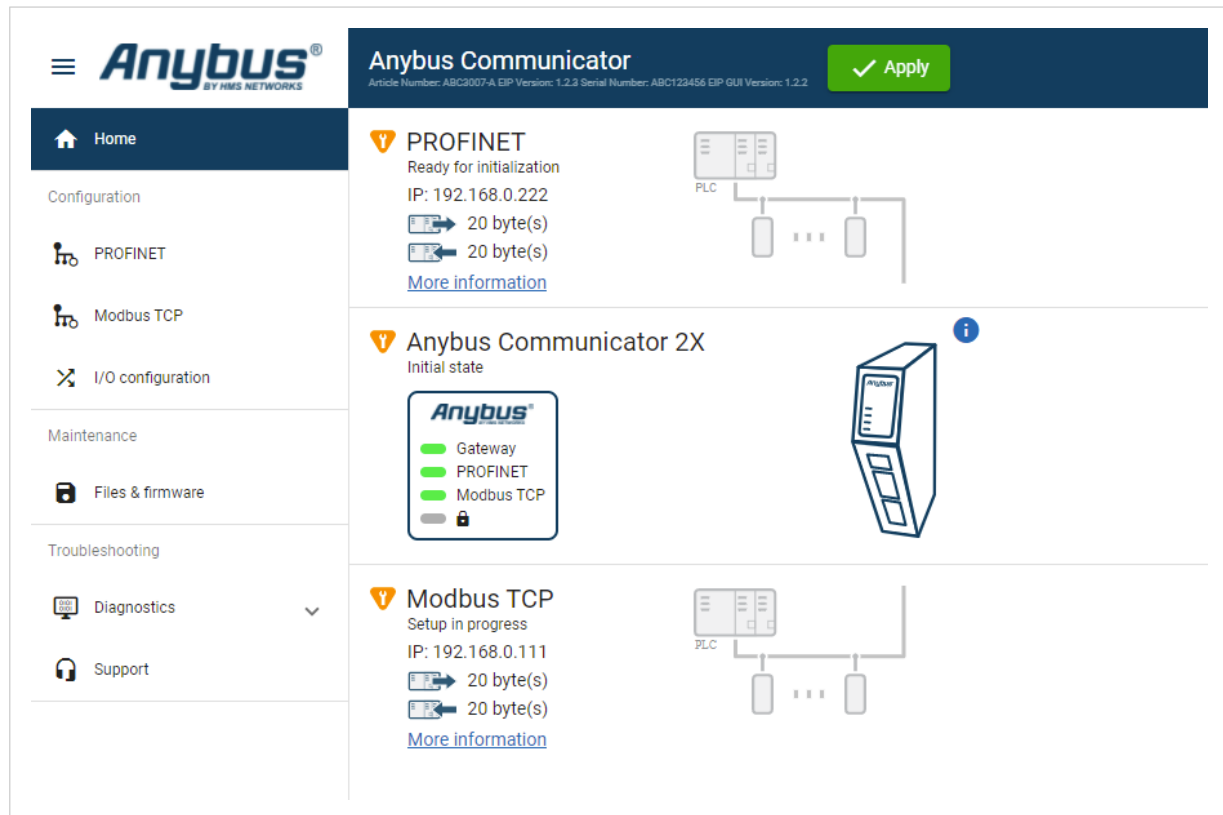

Figure 13. The Communicator built-in web interface Home page

Menu item	Description
Home	View the Communicator, network and node status.
Apply	After configuration changes are made and verified, press Apply to make the settings take effect.
PROFINET	Configure the network settings for the PROFINET network.
Modbus TCP	Configure the network settings for the Modbus TCP network.
I/O configuration	Configure input and output data sizes and endian conversion.
Files & firmware	Save settings in a configuration files, upload configuration files and upgrade firmware.
Diagnostics	Monitor and troubleshoot the Communicator.
Support	Contains Communicator product information, Anybus contact information, link to Anybus support website, and product file for download. Here you can generate a support package with product information, to send to your Anybus support technician.

6.5. PROFINET Settings

6.5.1. PROFINET IP Settings

To Use DHCP Server

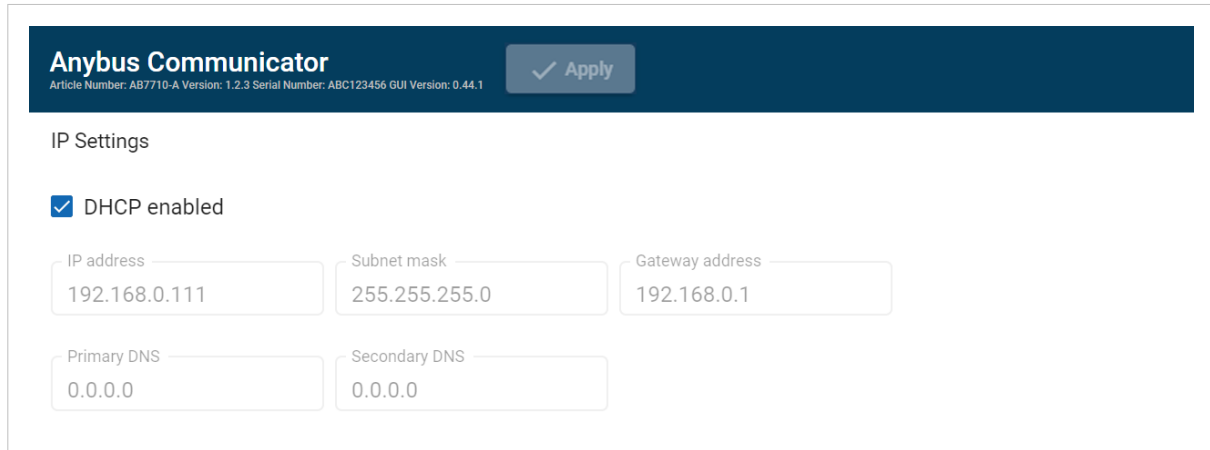

The screenshot shows the 'Anybus Communicator' web interface. At the top, there is a dark blue header with the product name and version information (Article Number: AB7710-A, Version: 1.2.3, Serial Number: ABC123456, GUI Version: 0.44.1) and an 'Apply' button with a checkmark. Below the header, the 'IP Settings' section is visible. A checkbox labeled 'DHCP enabled' is checked. Below this, there are five input fields: 'IP address' (192.168.0.111), 'Subnet mask' (255.255.255.0), 'Gateway address' (192.168.0.1), 'Primary DNS' (0.0.0.0), and 'Secondary DNS' (0.0.0.0).

Figure 14. IP Settings, DHCP enabled

By default, DHCP is disabled.

To enable DHCP, select the **DHCP enabled** checkbox. The IP settings will be provided by the high level network DHCP server.

To Configure IP Settings Manually

Anybus Communicator
Article Number: AB7710-A Version: 1.2.3 Serial Number: ABC123456 GUI Version: 0.44.1

IP Settings

DHCP enabled

IP address: 192.168.1.15 Subnet mask: 255.255.255.0 Gateway address: 0.0.0.0

Primary DNS: 0.0.0.0 Secondary DNS: 0.0.0.0

Figure 15. PROFINET IP Settings, DHCP disabled

1. Ensure that the **DHCP enabled** checkbox is deselected.
2. Configure the IP settings.

Setting	Description
IP address	The PROFINET network IP address in IPv4 dot-decimal notation
Subnet mask	The PROFINET network Subnet mask in IPv4 dot-decimal notation.
Gateway address	The PROFINET network Gateway address in IPv4 dot-decimal notation. If there is no gateway available, set the Gateway address to: 0.0.0.0
Primary DNS server	The PROFINET network Primary DNS in IPv4 dot-decimal notation.
Secondary DNS server	The PROFINET network Secondary DNS in IPv4 dot-decimal notation.
DHCP	Off
Hostname	You can label the Communicator. Maximum length is 64 characters. No symbol characters, punctuation characters, or whitespace are permitted. Write the Hostname as one single word.

If you change a value and click **Refresh**, the value is reset to the last applied value.

Naming the Host

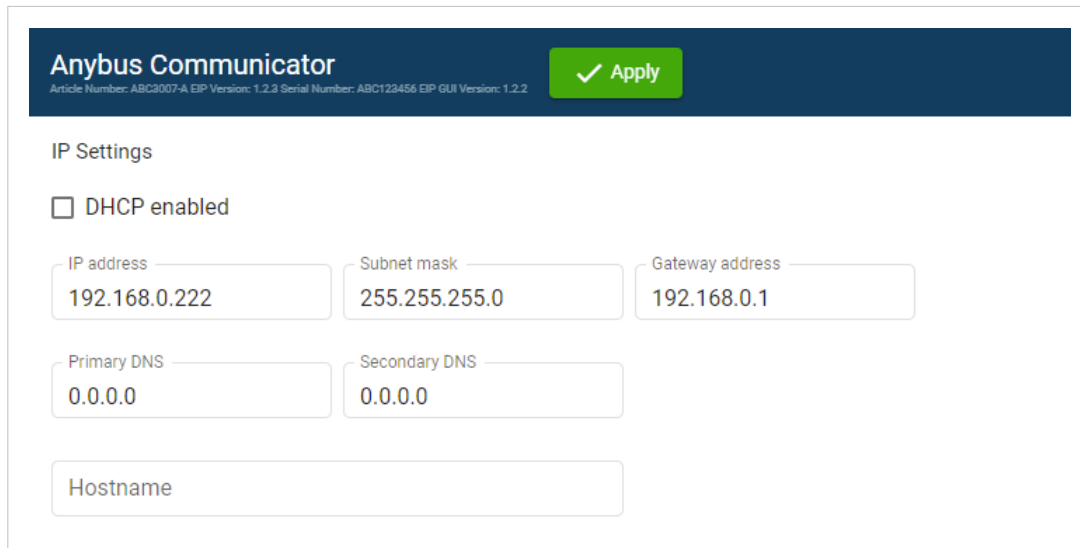

The screenshot shows the 'Anybus Communicator' configuration interface. At the top, there is a dark blue header with the product name and a green 'Apply' button. Below the header, the 'IP Settings' section is visible. A checkbox for 'DHCP enabled' is unchecked. The IP address is set to 192.168.0.222, the Subnet mask to 255.255.255.0, and the Gateway address to 192.168.0.1. The Primary DNS and Secondary DNS are both set to 0.0.0.0. At the bottom of the IP Settings section, there is a text input field labeled 'Hostname'.

Figure 16. IP Settings Hostname

You can label the Communicator.

- The maximum allowed length of the Hostname is 64 characters.
- No symbol characters, punctuation characters, or whitespace are permitted.
- Write the Hostname as one single word.

6.5.2. PROFINET Station Name Settings

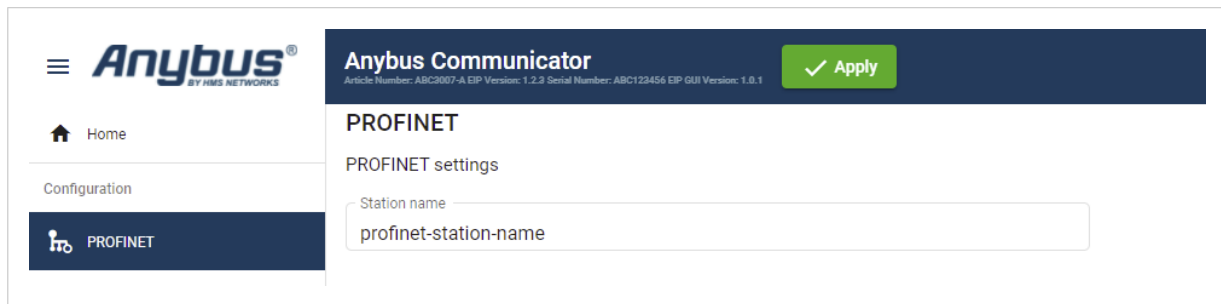

Figure 17. Modbus TCP page, Station name

A PROFINET device is identified by its Station name in the PROFINET network.

Enter a Station name for the Communicator.

- The maximum allowed length of the Station name is 240 characters.
- No symbol characters, punctuation characters, or whitespace are permitted.
- Write the Station name as one single word.

6.6. Modbus TCP Settings

6.6.1. Modbus TCP IP Settings

To Use DHCP Server

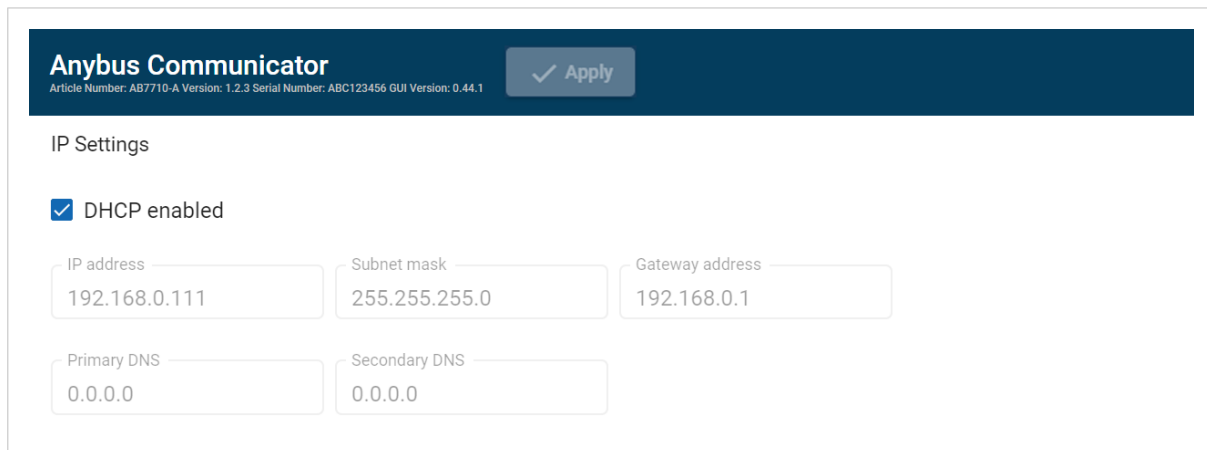

Figure 18. IP Settings, DHCP enabled

By default, DHCP is disabled.

To enable DHCP, select the **DHCP enabled** checkbox. The IP settings will be provided by the high level network DHCP server.

To Configure IP Settings Manually

Anybus Communicator
Article Number: AB7710-A Version: 1.2.3 Serial Number: ABC123456 GUI Version: 0.44.1

IP Settings

DHCP enabled

IP address: 192.168.1.15 Subnet mask: 255.255.255.0 Gateway address: 0.0.0.0

Primary DNS: 0.0.0.0 Secondary DNS: 0.0.0.0

✓ Apply

Figure 19. Modbus TCP IP Settings, DHCP disabled

1. Deselect the **DHCP enabled** checkbox.
2. Configure the IP settings.

Setting	Description
IP address	The Modbus TCP network IP address in IPv4 dot-decimal notation
Subnet mask	The Modbus TCP network Subnet mask in IPv4 dot-decimal notation.
Gateway address	The Modbus TCP network Gateway address in IPv4 dot-decimal notation. If there is no gateway available, set the Gateway address to: 0.0.0.0
Primary DNS	The Modbus TCP network Primary DNS in IPv4 dot-decimal notation.
Secondary DNS	The Modbus TCP network Secondary DNS in IPv4 dot-decimal notation.
Hostname	You can label the Communicator. Maximum length is 64 characters. No symbol characters, punctuation characters, or whitespace are permitted. Write the Hostname as one single word.

If you change a value and click **Refresh**, the value is reset to the last applied value.

Naming the Host

Figure 20. IP Settings Hostname

You can label the Communicator.

- The maximum allowed length of the Hostname is 64 characters.
- No symbol characters, punctuation characters, or whitespace are permitted.
- Write the Hostname as one single word.

6.6.2. Timeout Time Settings

Figure 21. Modbus TCP page, Timeout times

Connection Timeout

Specify how long a Modbus TCP connection may be idle before it is closed by the Communicator.

The default value is 60 seconds.

To disable **Connection timeout**, set the value to 0.

Process Data Active Timeout

Specify the maximum allowed time between two incoming messages in steps of 10 ms.

If this time is exceeded, the high level network is considered to be offline.

The data sent to the sub-network is frozen.

A value of 0 disables this feature, i.e. the high level network can never go offline.

The default value is 0 ms.

6.7. I/O Configuration

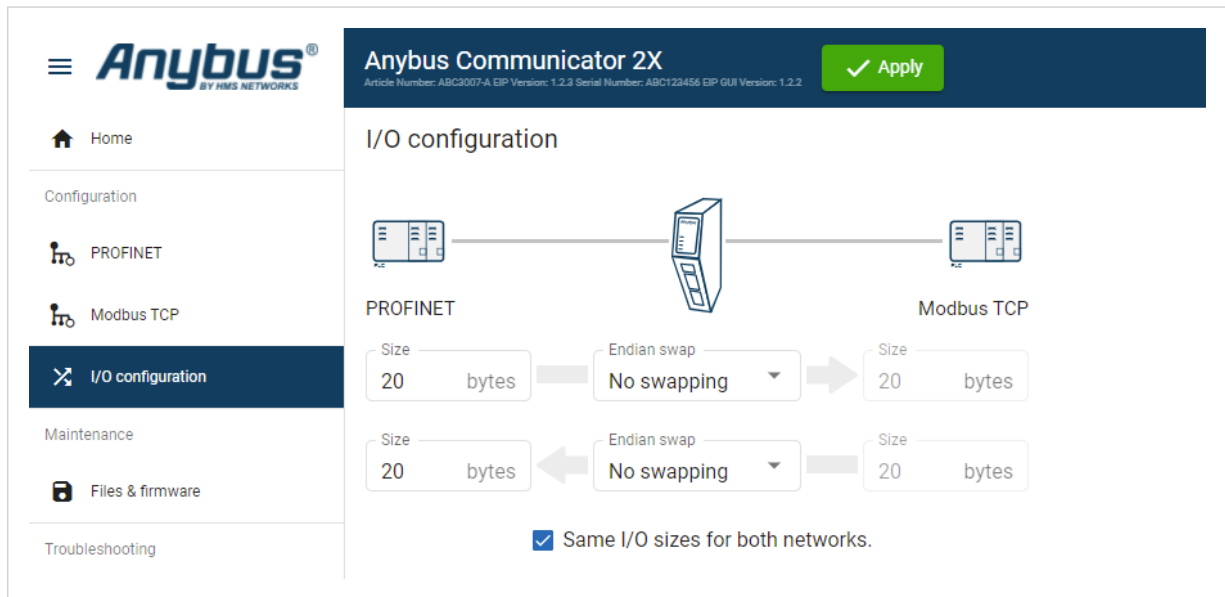

Figure 22. I/O configuration page

Enter the desired **Size** for the network input data and output data.

By default, the Communicator is set to use the same I/O sizes for both the PROFINET and the Modbus TCP networks.

To configure different sizes for the networks, deselect the **Same I/O sizes for both networks** checkbox.

Endian Swap

Big-endian

The big-endian format places the most significant byte of the data at the byte with the lowest memory address.

Little-endian

The little-endian format places the least significant byte of the data at the byte with the lowest memory address.

Convert Between Big-Endian and Little-Endian

To convert between big-endian and little-endian you must reverse the byte order.

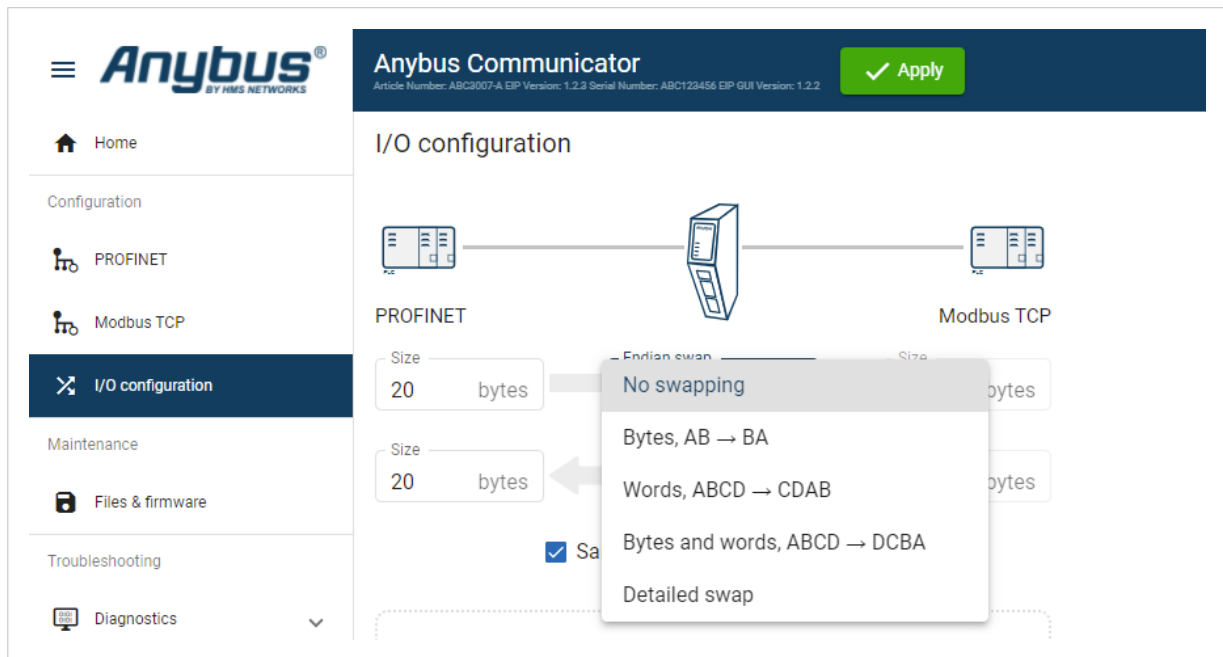

Figure 23. I/O data map, Endian swap

To reverse the byte order:

1. In the web-interface left sidebar menu, click **I/O configuration**.
2. Select the endian swap type from the **Endian swap** drop-down menu.

Setting	Description
No swapping	Default setting No swapping is performed on the data.
Bytes	Swap 2 bytes A B C D becomes B A D C
Words	Swap 4 bytes A B C D becomes C D A B
Bytes and words	A B C D becomes D C B A
Detailed swap	With Detailed swap, you can select a Endian swap method for each byte in the I/O Configuration. Set the endian swap type No swap , Bytes, AB → BA , Word swap, ABCD → CDAB or Bytes and words, ABCD → DCBA for each bite. See Build Detailed Endian Swap (page 31) .

3. To apply the settings, click **Apply** in the web-interface header, and follow the instructions.

Build Detailed Endian Swap

If you have multiple data types, you can use the **Detailed endian swap** to change different parts of the data area in different ways.

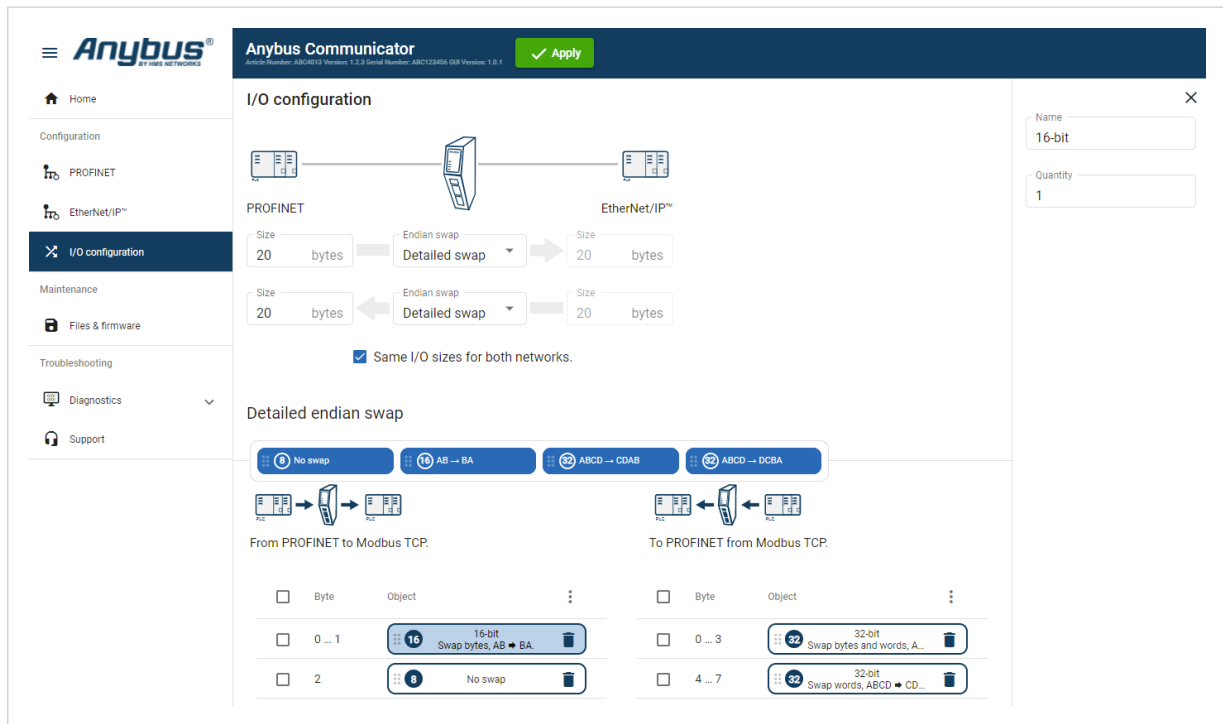

Figure 24. Detailed endian swap example

1. In the **Endianness** drop-down menu for the desired network(s), select **Detailed swap**.
 2. Build the detailed endian swap.
- To add an endian swap object: Drag and drop the desired endian swap object from the toolbar into the drag and drop fields.

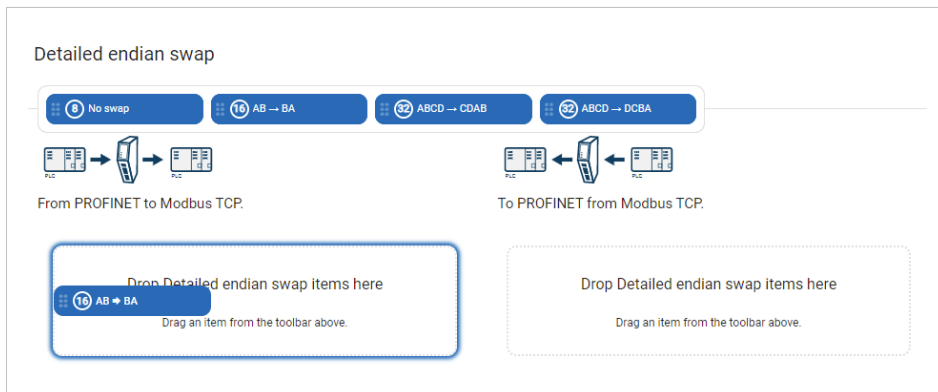

Figure 25. Add endian swap object(s)

- To duplicate an endian swap object: Select the checkbox in front of the endian swap object that you want to duplicate and click the **Duplicate selected** button.
You can select multiple endian swap objects and duplicate the group.

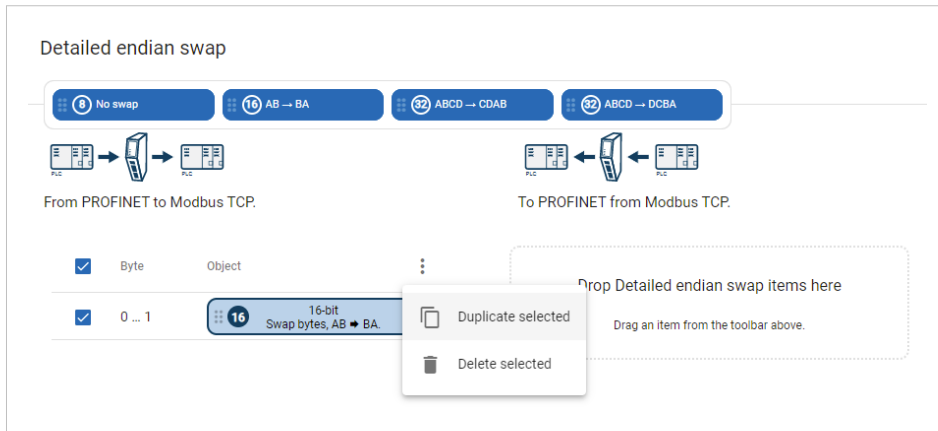

Figure 26. Duplicate endian swap object

- To change the order of the endian swap objects, drag and drop the endian swap objects in the list.

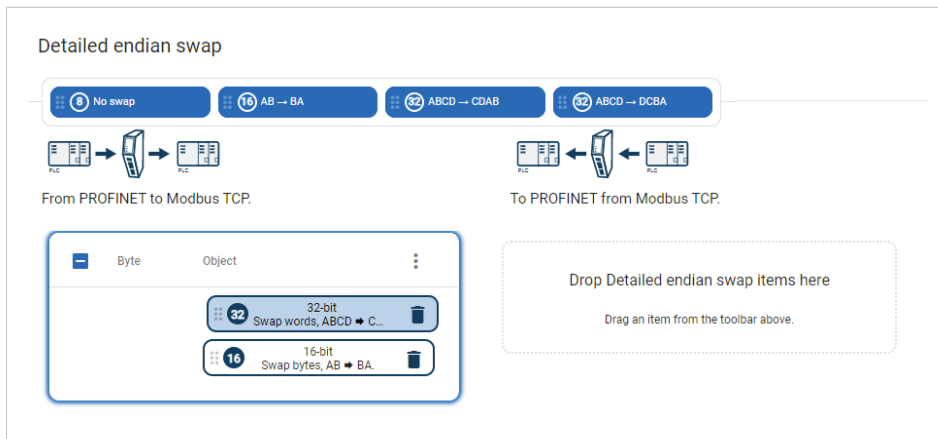

Figure 27. Change endian swap objects order

6.8. Configuration Notes

You can add notes to describe the Communicator configuration.

6.8.1. Add Configuration Note

Procedure

1. To open the **Configuration Notes** window, click on the **comments** icon .



Figure 28. Configuration note, comment icon

2. To add a new configuration note, click **Add**.

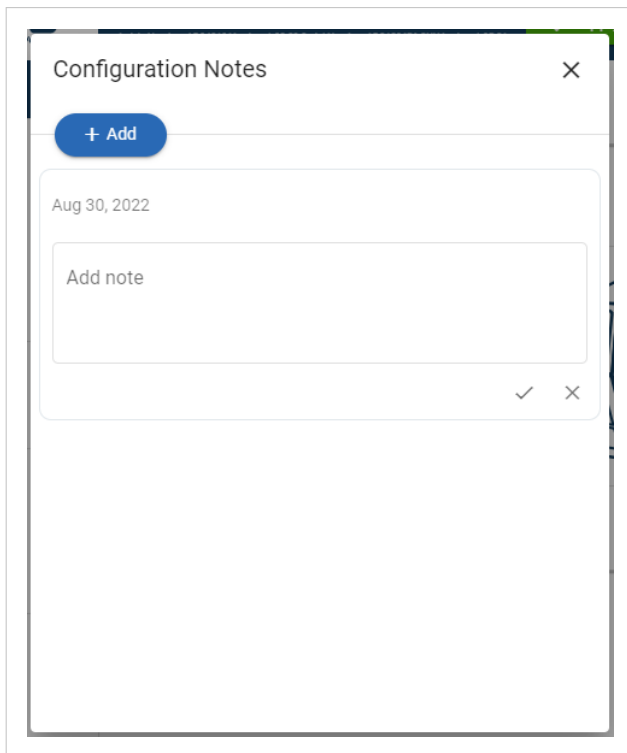

Figure 29. Add new configuration note

3. Write your configuration note and click **accept** ✓ .

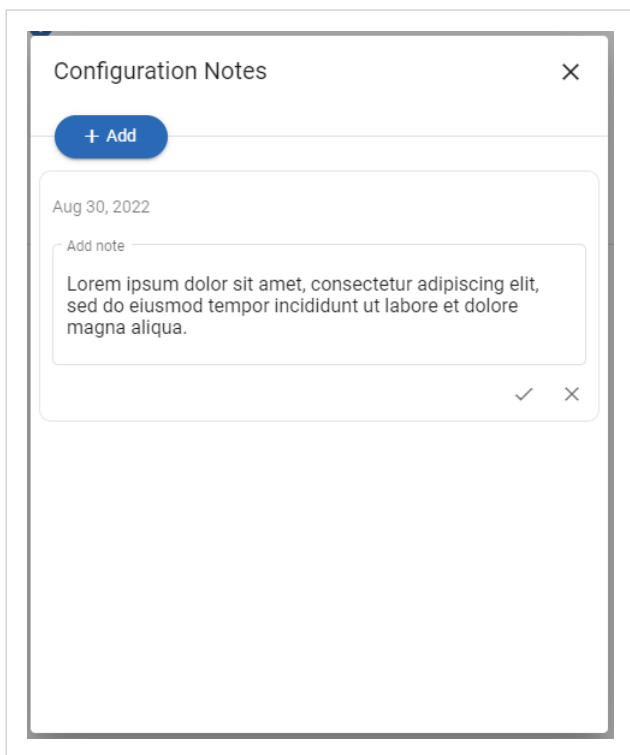

Figure 30. Write a configuration note

The configuration note is added to the list.

4. To close the window, click **close** ✕ .
5. To save the configuration note, click **Apply** in the web-interface header, and follow the instructions.

6.8.2. View and Edit Configuration Notes

To view and/or edit a note, click on the **comments** icon .



Figure 31. Example: The comment icon indicates that there are three added notes

The configuration notes are listed in the **Configuration Note** window.

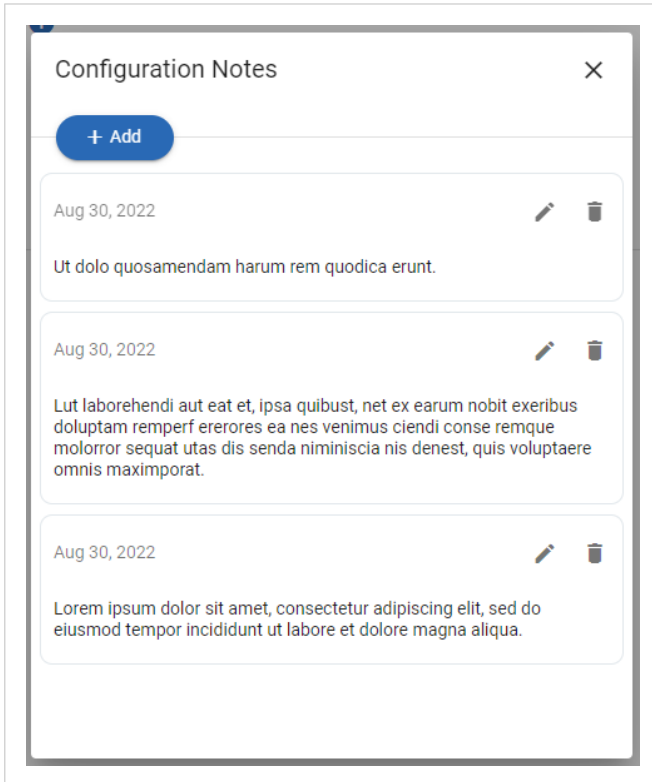

Figure 32. Example: The Configuration Notes window with added notes

6.9. Apply Configuration

Before You Begin



NOTE

When you apply the configuration, any existing configuration is overwritten.

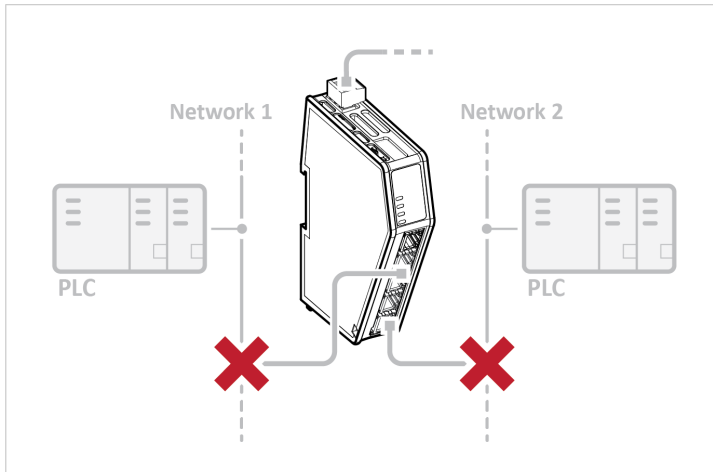

Figure 33.

Before you can apply the configuration, ensure that there is no active communication on the PROFINET network or the Modbus TCP network where the Communicator is connected.

Procedure

To make the settings take effect, download the configuration to the Communicator:

1. In the web-interface header, click **Apply**



2. To confirm download, click **Apply**.
The configured settings are downloaded and applied to the system.

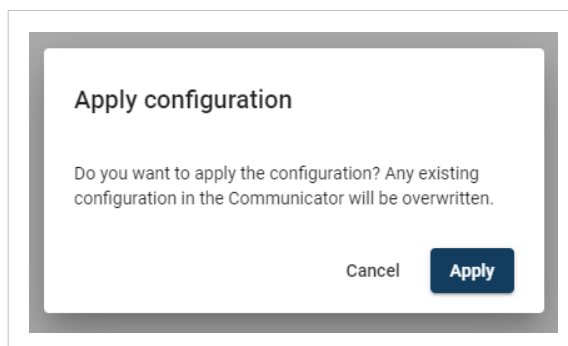

7. PLC Configuration

7.1. Export Product GSDML File

Option for PROFINET IO-Device.

Option if the PLC program requires a product file, GSDML (Generic Station Description Markup Language) file, describing how the Communicator can be used on the high level network.

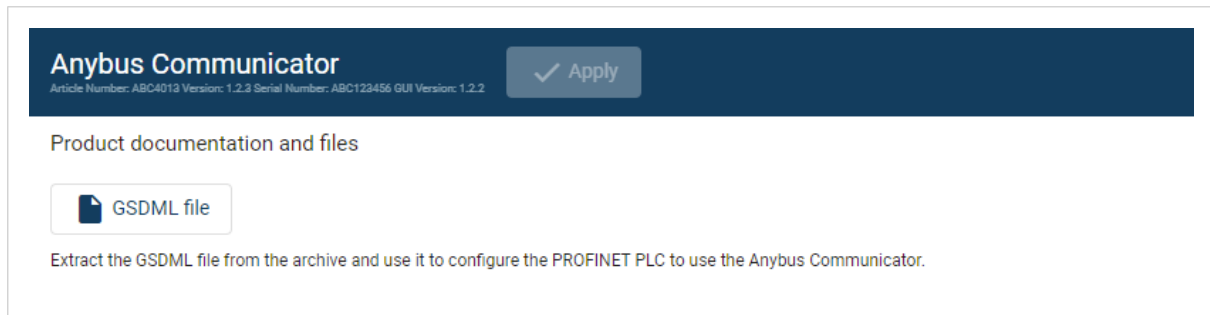

Figure 34. Files & firmware page, PROFINET GSDML file

You find the *PROFINET GSDML* file on the Communicator built-in web interface **PROFINET** page, **Files & firmware** page and on the **Support** page.

To export the GSDML file:

- Click **GSDML** file.
The GSDML file is downloaded to your PC.

7.2. Addressing and Register Mapping

For information about the Modbus Transactions, see [Modbus Data Model](#) and [Modbus Transactions](#).

7.2.1. The Difference Between Address and Register Start

To read or write data from a Modbus TCP device you can use either Address or Register.

For information on whether to use Register or Address, see [Nodes and Transactions](#) and the user documentation for the client device and the node(s) that will be exchanging data.



TIP

If Register is used, add +1 to the Address value.

Example 1. Modbus Function Code 0x04 Read Input Registers

Table 1. Modbus client values

Address	Register	Register
0	1	30001
1	2	30002
2	3	30003

Example 2. Modbus Function Code 0x03 Read Holding Registers

Table 2. Modbus client values

Address	Register	Register
0	1	40001
1	2	40002
2	3	40003

7.2.2. To Read and Write Data

To Read Data

To read data you can use different Modbus Functions.

Discrete Inputs

- Modbus Function 0x02 Read Discrete Input Status

Discrete Input start at address 0.

Input Registers

- Modbus Function 0x04 Read Input Register
- Modbus Function 0x10 Read Holding Registers

The Input Registers starts at address 0 which corresponds to Register 1.

To use Read Holding Registers the address is offset to address 2048 which corresponds to Register 2049.

The first Input Register (30001)

The first Input Register (30001) can be read using Modbus Function code 0x04 Read Input Registers at Address 0 or Register 1.

You can also use Read Holding Registers (Modbus Function code 0x03) to read the same data (at Address 42048 = Register 42049) or use Read Discrete Inputs 0x02 at address 0..15.

To Write Data

To write data you can use different Modbus Functions.

Coils

- Modbus Function 0x05 Force Single Coil
- Modbus Function 0x0F Force Multiple Coils

Coils starts at address 0.

For Modbus Function 0x05 Force Single Coil a value of FF 00 requests the coil to be ON, a value of 00 00 requests the coil to be OFF.

Holding Registers

- Modbus Function 0x06 Write Single Register
- Modbus Function 0x10 Write Multiple Registers

The Holding Registers starts at address 0 which corresponds to Register 1.

Holding Register (40001)

The first Holding Register (40001) can be written to using Modbus Function code 0x06 Write Single Register at Address 0 or Register 1.

To read back what has been written, you can use Read Holding Registers 0x03 at address 0..749 = Register 1..750 (40001..40750) or Read Coils 0x01 at address 0..11999.

7.2.3. Data From PROFINET to Modbus TCP Network

Input Data to PLC

Process I/O data offset		Discrete input address		Input register address		Holding register address	
HEX	DEC	HEX	DEC	HEX	DEC	HEX	DEC
0x0000 — 0x0001	0 — 1	0x0000 — 0x000F	0 — 15	0x0000	0	0x0800	2048
0x0002 — 0x0003	2 — 3	0x0010 — 0x001F	16 — 31	0x0001	1	0x0801	2049
...
0x05D8 — 0x05D9	1496 — 1497	0x2EC0 — 0x2ECF	11968 — 11983	0x02EC	748	0x0AEC	2796
0x05DA — 0x05DB	1498 — 1499	0x2ED0 — 0x2EDF	11983 — 11999	0x02ED	749	0x0AED	2797

7.2.4. Data From Modbus TCP Network to PROFINET

Output Data From PLC

Process I/O data offset		Coil address		Holding register address	
HEX	DEC	HEX	DEC	HEX	DEC
0x0000 — 0x0001	0 — 1	0x0000 — 0x000F	0 — 15	0x0000	0
0x0002 — 0x0003	2 — 3	0x0010 — 0x001F	16 — 31	0x0001	1
...
0x05D8 — 0x05D9	1496 — 1497	0x2EC0 — 0x2ECF	11968 — 11983	0x02EC	748
0x05DA — 0x05DB	1498 — 1499	0x2ED0 — 0x2EDF	11983 — 11999	0x02ED	749

7.2.5. Idle Mode

Transaction	Holding Register	Description
Enter/Exit Idle Mode	0x1004	Used by the Modbus TCP client to indicate an idle/offline mode on the network.

8. Verify Operation

8.1. Communicator Status Monitor

On the Home page, you can get a quick overview of the network and the Communicator operating status.

The screenshot displays the Anybus Communicator web interface. The top header includes the Anybus logo and a navigation menu with options like Home, Configuration, PROFINET, Modbus TCP, I/O configuration, Maintenance, Files & firmware, Troubleshooting, Diagnostics, and Support. The main content area is titled 'Anybus Communicator' and features three status cards:

- PROFINET:** Status is 'Ready for initialization'. IP: 192.168.0.222. Data transfer is shown as 20 byte(s) in both directions. A network diagram shows a PLC connected to several devices.
- Anybus Communicator 2X:** Status is 'Initial state'. A status box shows 'Gateway', 'PROFINET', and 'Modbus TCP' as active (green), with a lock icon below. An information icon is present. A physical device image is shown.
- Modbus TCP:** Status is 'Setup in progress'. IP: 192.168.0.111. Data transfer is shown as 20 byte(s) in both directions. A network diagram shows a PLC connected to several devices.

Figure 35. Home page

Gateway status





Overview the Communicator LED indications remotely.

Refer to [Communicator LED Indicators](#).

Network Status and Settings

Overview communication status and the current networks settings.

Status Symbols

Symbol	Description
	Internal error has occurred and operation cannot be guaranteed.
	Out of Specification.
	Check Function: <ul style="list-style-type: none"> • Initial state where non network components are started and configured. • Network startup in progress. • Invalid configuration detected.
	Normal operation.

8.2. Communicator LED Indicators



NOTE

Before you can verify operation you must configure the Communicator.

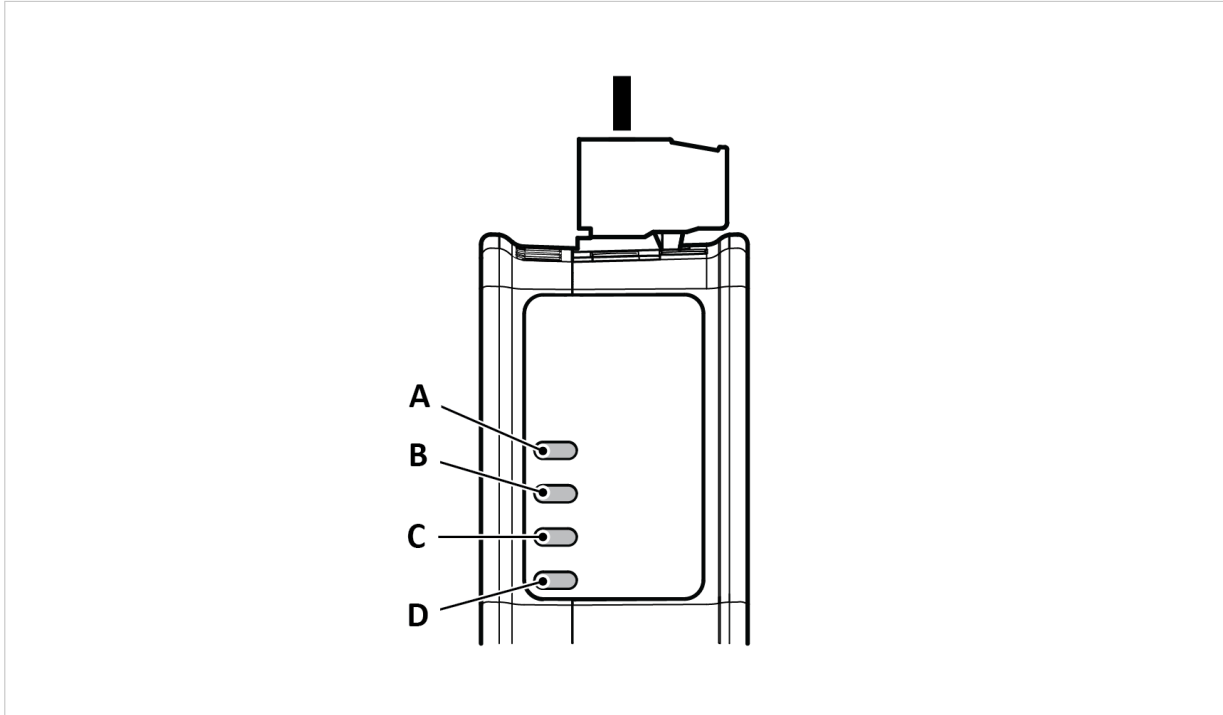

Figure 36. Gateway status (A), Lower connector (B), Upper connector (C) and (D) Security Switch

LED A - Gateway status	
Operation Status	Description
Off	No power
Green, flashing	Startup phase
Green, solid	Operational
Red, solid	Exception/Fatal error
Red, flashing	Invalid configuration
Green/Red, flashing	Power up self-test/Firmware update/Firmware recovery

LED B - PROFINET, Upper connector				
LED C - Modbus TCP, Lower connector				
Operation Status	EtherCAT	EtherNet/IP	Modbus TCP	PROFINET
Off	No power/EtherCAT device in 'INIT'-state	No power/No EtherNet/IP IP address	No power/ No Modbus TCP IP address	No power/No connection with IO controller
Green, flashing	EtherCAT device in 'PRE-OPERATIONAL'-state	EtherNet/IP online, no connections established	Modbus TCP online, no messages received	Used by engineering tools to identify the node on the network
Green, one flash	EtherCAT device in 'SAFE-OPERATIONAL'-state	N/A	N/A	Connection with IO controller established IO controller in STOP state or IO data bad

*The EtherCAT RUN (green) and ERROR (red) LED behaviors are combined in LED (C)/(D). This can cause LED (C)/(D) to alternate between red and green. The LED behavior still represents the states described in the table above.

LED B - PROFINET, Upper connector				
LED C - Modbus TCP, Lower connector				
Operation Status	EtherCAT	EtherNet/IP	Modbus TCP	PROFINET
Green, solid	EtherCAT device in 'OPERATIONAL'-stat	EtherNet/IP online, one or more connections established	Modbus TCP online, at least one message received	PROFINET online, one or more connections established
Red, solid	FATAL event	Duplicated EtherNet/IP IP address	IP address conflict detected	FATAL event
Red, one flash	Unsolicited state change SubDevice application has changed the EtherCAT state autonomously.	N/A	N/A	Station name not set
Red, two flash	Sync Manager watchdog timeout	N/A	N/A	IP address not set
Red, three flash	N/A	N/A	N/A	Expected Identification differs from Real Identification
Red, flashing	Invalid configuration	One or more connections timed out	Connection timeout	One or more connections timed out
Green/Red, flashing	EtherCAT RUN (green) and ERROR (red) LED combined*	N/A	N/A	N/A

*The EtherCAT RUN (green) and ERROR (red) LED behaviors are combined in LED (C)/(D). This can cause LED (C)/(D) to alternate between red and green. The LED behavior still represents the states described in the table above.

LED D - Security switch	
Operation Status	Description
Off	No power/Security switch is unlocked/Exception/Fatal error
Green	Security switch is locked

Fatal Error and Exception Error

Fatal error: A fatal error causes the Communicator firmware application to crash in an uncontrolled manner.

Exception error: An exception error causes the Communicator to enter a controlled error state. The Communicator firmware application is still running.

LED	Fatal error	Exception error
A	Red, solid	Red, solid
B	Red, solid	Off
C	Red, solid	Off
D	Off	Off

8.3. Ethernet LED Indicators

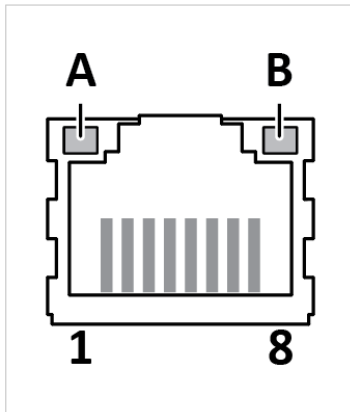

Figure 37. LED A. Activity LED B. Not used

LED A	Function
Off	No link (or no power)
Green	Link (100 Mbit/s) established
Green, flashing	Activity (100 Mbit/s)
Yellow	Link (10 Mbit/s) established
Yellow, flashing	Activity (10 Mbit/s)

LED B	Function
Off	Not used

9. Maintenance

9.1. Configuration File Handling

9.1.1. Export Configuration

You can export the current configuration, in order to import and use the same settings to configure additional Communicator.

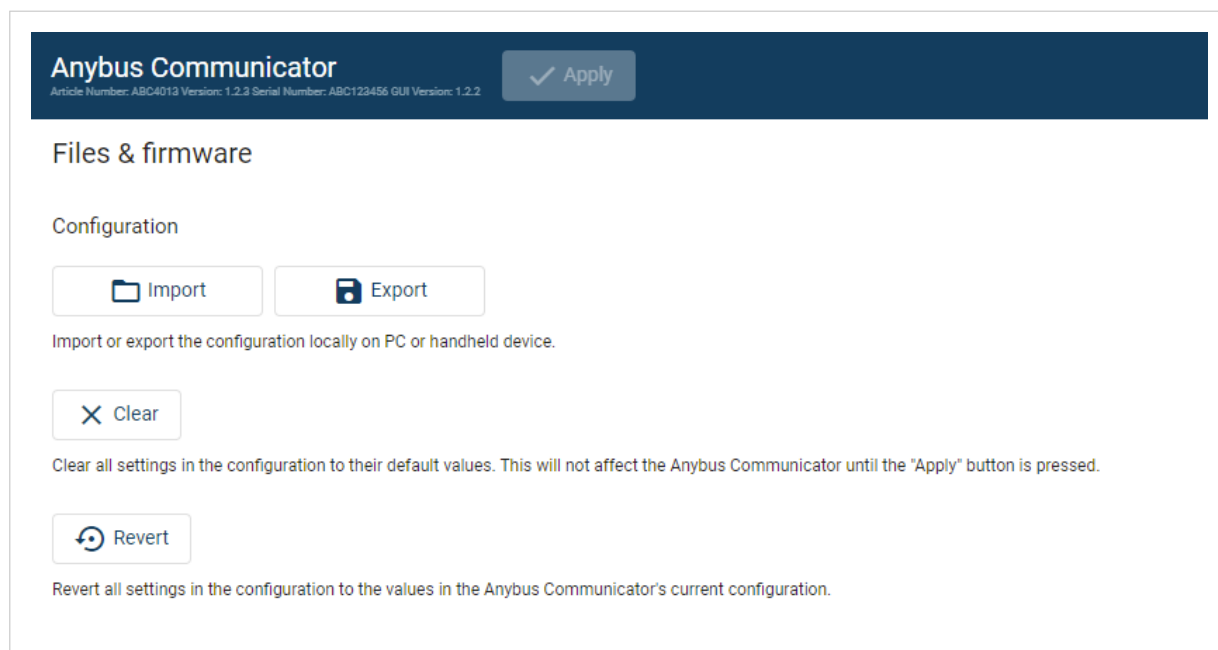

Figure 38. Files & firmware page

To export a configuration file:

- In **Files & firmware**, click **Export**.
The configuration settings are stored in a .conf file and downloaded to your PC.

9.1.2. Import Configuration

To easily configure multiple Communicator with the same settings, you can import a configuration file.

Before You Begin

The supported file format is .conf.

Procedure

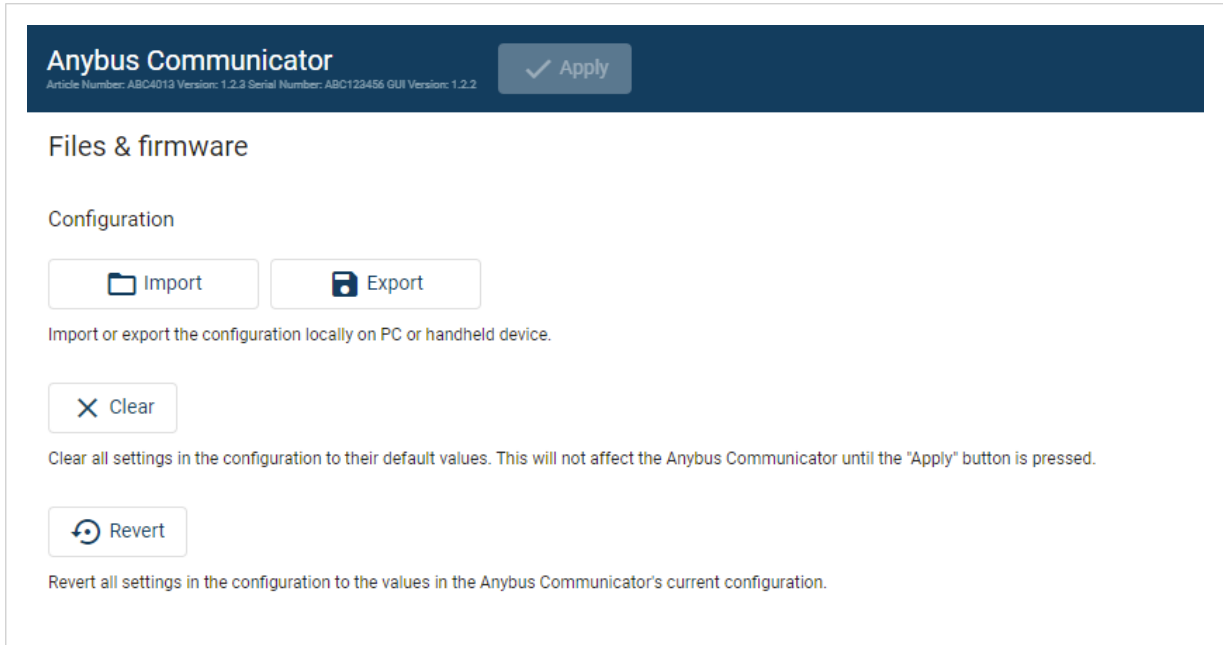

Figure 39. Files & firmware page

Import configuration file:

1. On the **Files & firmware** page, click **Import**.
2. In the Import configuration window, click **Select file (.conf)**.
3. In the Open dialog box, browse to and select the configuration file and click **Open**.
4. In the Import configuration window, click **Import**.
5. In the Communicator address settings window:
 - To import IP settings from the selected configuration file, click **Imported settings**. All configuration settings are imported.
 - To continue using the current IP settings, click **Configured settings**. All configuration settings except the IP settings are imported.
6. The configuration file is parsed.
 - If the configuration is compatible, the settings are imported.
 - If any compatibility mismatches occurs, a message about the mismatch appears.
7. To apply the settings, click **Apply** in the web-interface header, and follow the instructions.

9.2. Clear and Revert Configuration

You can restore all settings in a configuration to the default settings.

Procedure

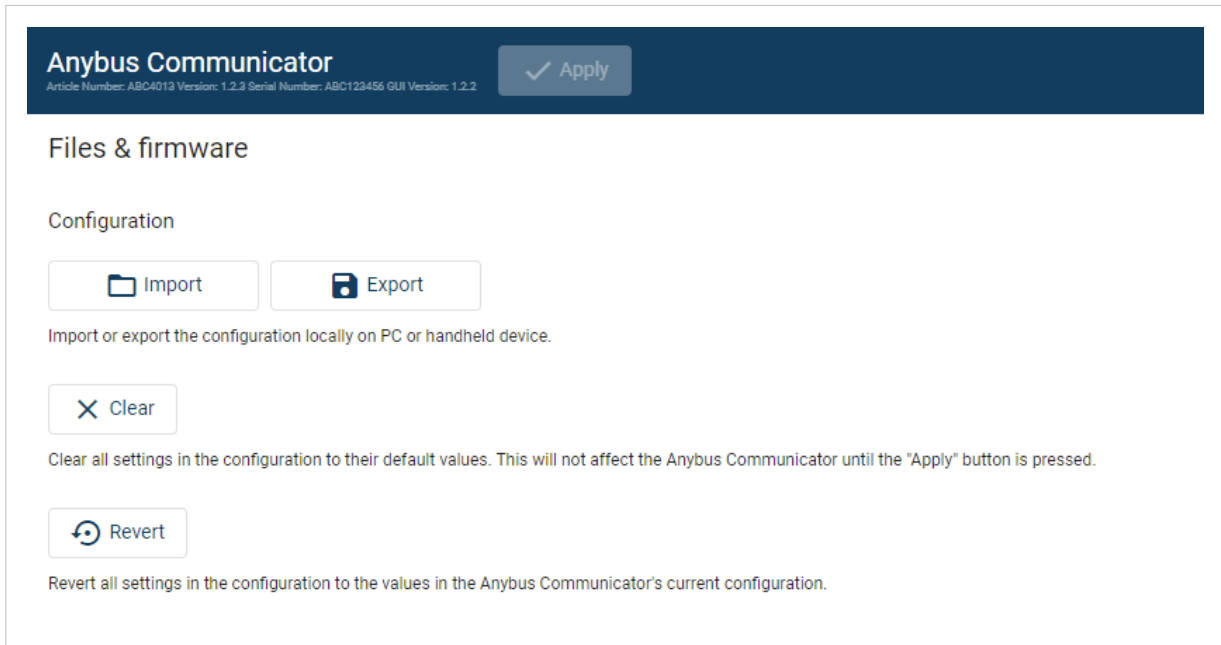

Figure 40. Files & firmware page

To Clear the Configuration

When you want to clear a configuration and return to the default settings.

1. On the **Files & firmware** page, click **Clear**.
2. In the Confirm clear window, click **Clear**.
3. To apply the change, click **Apply** in the web-interface header, and follow the instructions.

To Revert the Configuration

When you want to remove any configuration made in a current session and re-load the configuration from the gateway.

1. On the Files & firmware page, click **Revert**.
2. In the Confirm revert window, click **Revert**.
3. To apply the change, click **Apply** in the web-interface header, and follow the instructions.

9.3. Firmware Management

9.3.1. View the Firmware Version

On the **Support** page, you can view the current applied firmware version.



Figure 41. Support page, Product information example

9.3.2. Firmware and Configuration Compatibility

Compatibility after firmware upgrade

Current configuration is still compatible after upgrading the firmware.

Compatibility after firmware downgrade

9.3.3. Firmware File Validation

Before the firmware file is imported into the system, the firmware upgrade function perform a validation of the file, to ensure that:

- the firmware is compatible with the Communicator hardware
- the firmware is suited for the product
- the officially HMS software signatures are valid
- that the firmware file is not corrupt or damaged

If the firmware file does not pass the validation, the firmware file is rejected and an error message appear.

9.3.4. Update Firmware

Before You Begin

Ensure that the Communicator is disconnected from the OT networks.

Procedure

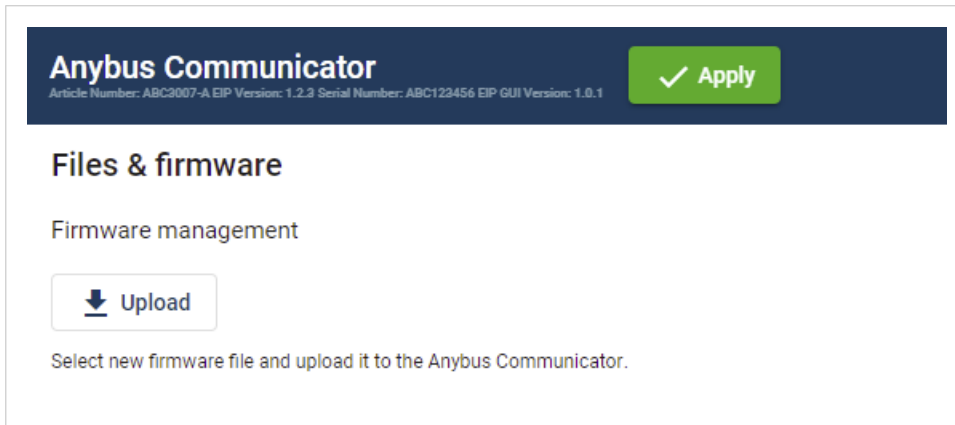

Figure 42. Files & firmware page

To update the firmware:

1. On the **Files & firmware** page, click **Upload**.
2. In the Upload Firmware window, click **Select firmware (.hiff)**.
3. In the Open dialog box, browse to and select the firmware file and click **Open**.
4. To start the firmware upgrade, click **Update firmware**.
The firmware file is validated and transferred.

Result

- If the firmware file pass the validation: The firmware is upgraded and then the Communicator automatically reboots, for the upgrade to take effect.
- If the firmware file is rejected: An error message appear.

10. Troubleshooting

10.1. Diagnostics

10.1.1. I/O Data

On the **Diagnostics, I/O data** page you can monitor how the data flow between the **PROFINET** side and the **Modbus TCP** side, including any configured endian conversions.

The screenshot displays the 'I/O data' monitoring page in the Anybus Communicator software. The interface includes a sidebar with navigation options such as Home, Configuration, Maintenance, and Troubleshooting. The main content area is titled 'I/O data' and features a 'Start' button, network selection buttons for 'PROFINET' and 'Modbus TCP', and display format buttons for 'Hex', 'Dec', and 'Ascii'. Two data tables are shown: 'Data from the PROFINET to the Anybus Communicator' and 'Data from the Anybus Communicator to the PROFINET'. Each table has columns for 'Address' and 'Data' and displays hexadecimal values for various address ranges. A timestamp is visible at the bottom of each table.

Address	Data
0 ... 7	00 01 02 03 04 05 06 07
8 ... 15	08 09 0a 0b 0c 0d 0e 0f
16 ... 23	10 11 12 13 14 15 16 17
24 ... 31	18 19 1a 1b 1c 1d 1e 1f
32 ... 39	20 21 22 23 24 25 26 27
40 ... 47	28 29 2a 2b 2c 2d 2e 2f
48 ... 55	30 31 32 33 34 35 36 37
56 ... 63	38 39 3a 3b 3c 3d 3e 3f

Figure 43. I/O data

The table can contain at most 10000 messages. When the limit is reached, the oldest messages are discarded when new messages are added.

Switch between the OT networks

To switch between the networks, select **PROFINET** or **Modbus TCP**.

Select how data is displayed

To choose if the data should be displayed in Hexadecimal, Decimal or ASCII, click **Hex**, **Dec** or **Ascii**.

Start and Stop Data flow

- To start the data flow, click **Start**.
- To end the data flow, click **Stop**.

10.1.2. Event Log

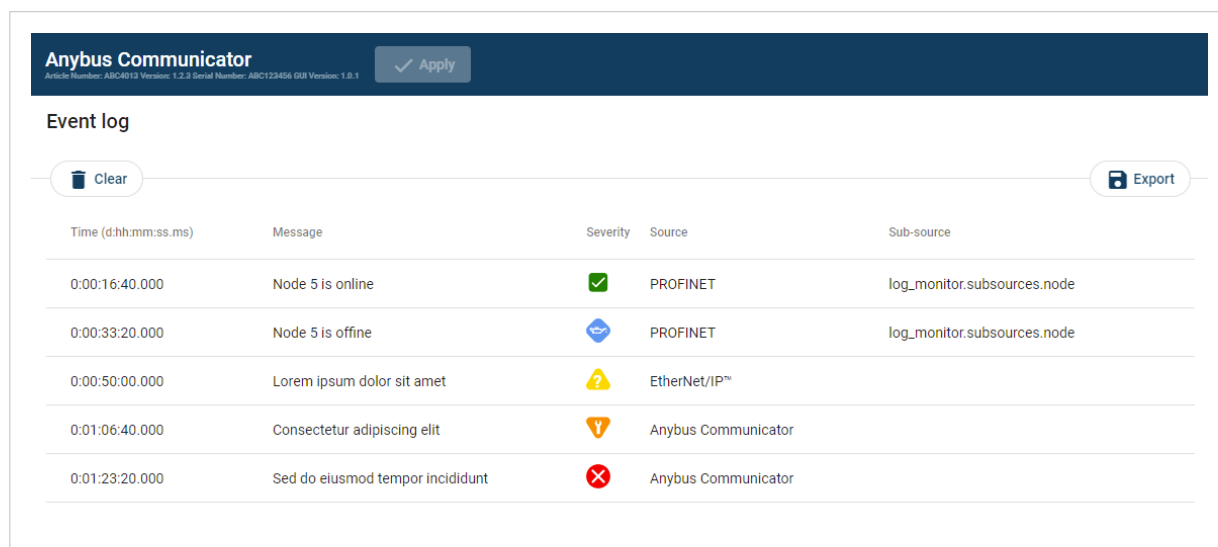

Figure 44. Event log page example

How To Analyze the Information

The log follows the FIFO principle, first in and first out. The oldest (first) value is processed first.

Time (d:hh:mm:ss.ms)	The date and time when the event occurred.	
Message	A brief description of the event.	
Severity	The severity of the event occurred. For description of the symbols, see Communicator Status Monitor .	
Source	0	Communicator
	1	Modbus TCP
	2	PROFINET

To clear the current log, click **Clear log**.

10.2. Reset to Factory Settings

Before You Begin

Procedure

To reset the Communicator:

1. Disconnect the Communicator from power.

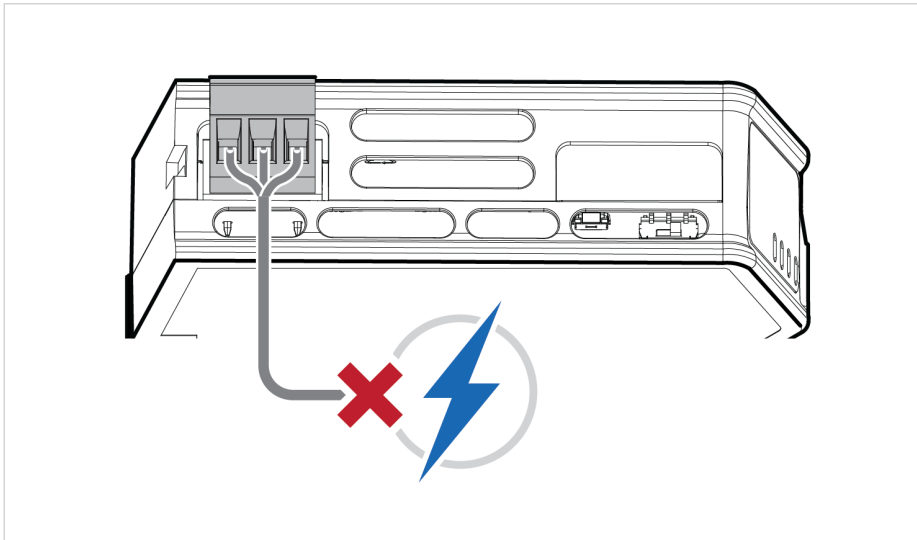

Figure 45. Disconnect power

2. Use a pointed object, such as a ballpoint pen to press and hold the **Reset** button.

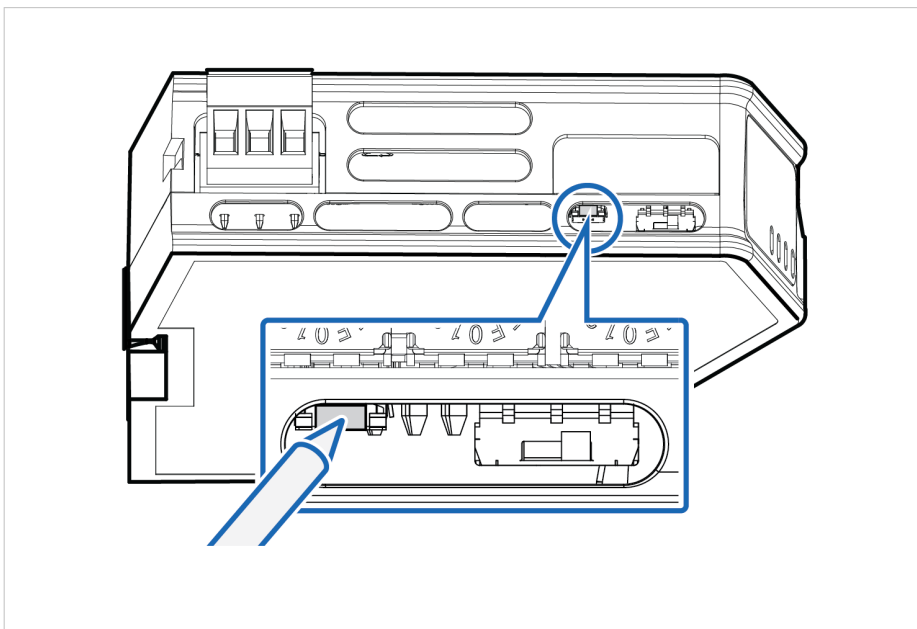

Figure 46. Press and hold **Reset** button

3. While holding the **reset** button, reconnect the Communicator to power.

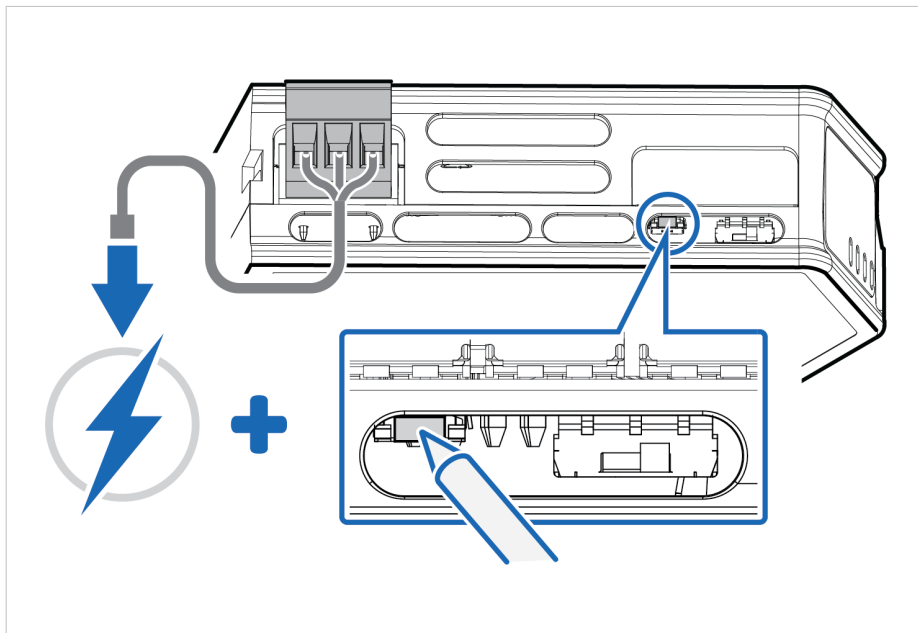

Figure 47. Hold **Reset** button and reconnect power

4. Release the **reset** button.
The Communicator enters exception state.
5. Reboot the Communicator.

Result

When the Communicator has successfully rebooted, the Communicator configuration is reset to the factory default configuration or the current configuration after firmware upgrade.

To Do Next

To ensure that the Communicator built-in web-interface is synchronized.

1. Open the the Communicator built-in web interface.
2. Navigate to the **Files & firmware** page and click **Revert**.

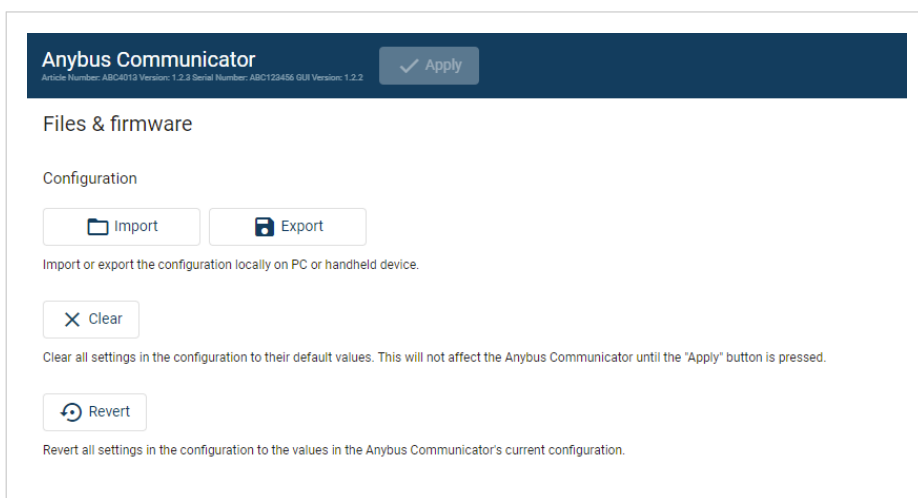

Figure 48. Files & firmware, Revert

10.3. Firmware Upgrade Error Management

If the firmware update process is interrupted or if the power is lost during the update process, the Communicator goes into fallback mode.

The last working firmware is still available on the flash, but it is not active.

Procedure

To complete the interrupted firmware update:

1. Disconnect the Communicator from power.

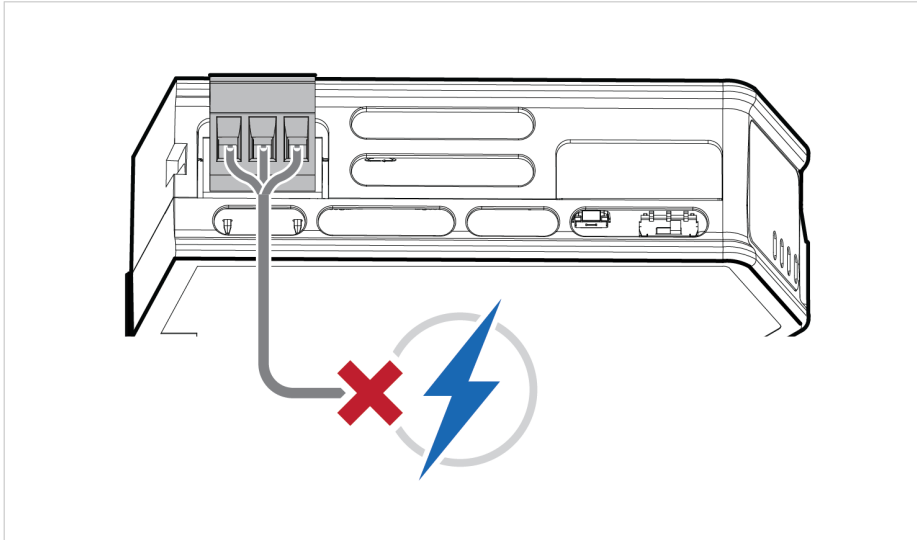

Figure 49. Disconnect power

2. Reconnect the Communicator to power.

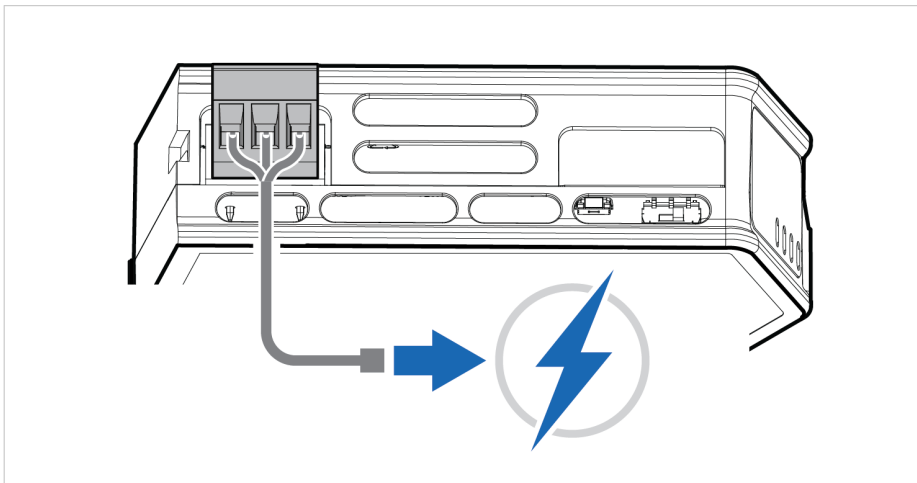

Figure 50. Reconnect power

3. Leave the Communicator for 10 minutes.
The Gateway status led indicator flashes red and green until the firmware upgrade is completed.

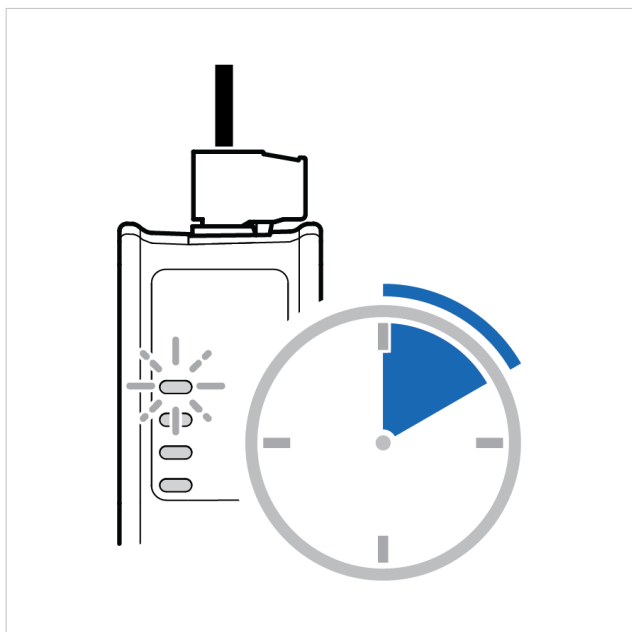

Figure 51. Firmware upgrade LED indication

Result

The Communicator recover and return to normal operation.

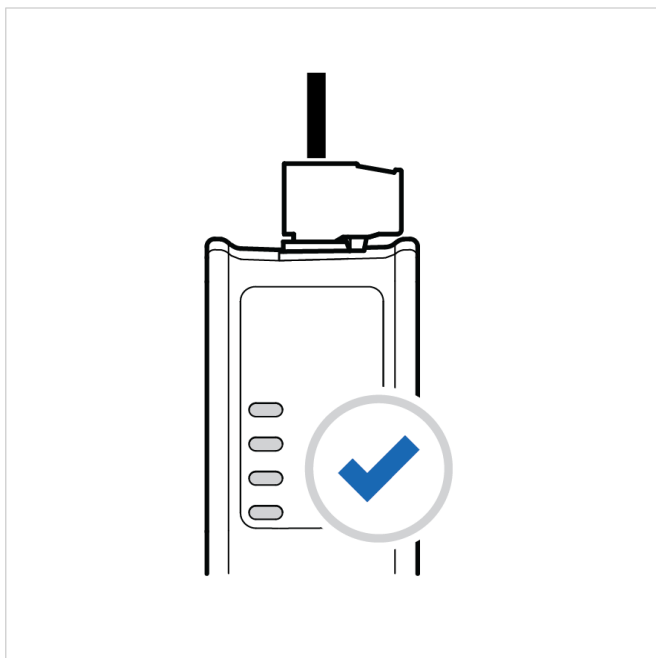

Figure 52. Recover and return to normal operation

To Do Next

To check LED status, refer to [Communicator LED Indicators](#).

10.4. Support

10.4.1. Support Package

Anybus Communicator
Article Number: ABC4013 Version: 1.2.3 Serial Number: ABC123456 GUI Version: 1.0.1



Support

Product information

Product name	Article Number	Serial Number	Version	GUI Version
Anybus Communicator	ABC4013	ABC123456	1.2.3	1.0.1

Product support website

[Anybus Communicator support website](#)
Get started videos, product documentation, latest firmware and device description files.

Scan to get to product support website.

Product documentation and files

Use the EDS file to configure the EtherNet/IP[™] PLC to use the Anybus Communicator.

Extract the GSDML file from the archive and use it to configure the PROFINET PLC to use the Anybus Communicator.

Support package

A support package contains product information that will help us to resolve your case.

Figure 53. Support page example

Before you create a ticket for technical support, generate a support package.

The support package contains information about what has occurred and will help the Anybus technical support team resolve the support case as quickly and efficiently as possible.

Support Package Content

The information in the support package is available to open and read, the files are not locked or encrypted.

Generate Support Package

On the **Support** page, click **Generate**.

A zip file with the support files is downloaded to your PC.

Create a Support Ticket

1. On the **Anybus Technical Support** page, navigate to the **Support Center** page and click **HMS Support Portal**.
2. In the **HMS Support Portal**, create a support ticket and upload the support package.

11. Technical Data

For complete technical specifications and regulatory compliance information, please visit www.anybus.com.

11.1. Technical Specifications

Article identification	ABC4017
Configuration connector	RJ45
Upper connector	RJ45 x 2
Lower connector	RJ45 x 2
Power connector	3-pin screw connector
Power supply	12-30 VDC, Reverse voltage protection and short circuit protection
Power consumption	Typical: 160 mA @ 24 V Max: 400 mA @ 12 V
Storage temperature	-40 to +85 °C
Operating temperature	-25 to +70 °C
Humidity	EN 60068-2-78: Damp heat, +40°C, 93% humidity for 4 days EN 60068-2-30: Damp heat, +25°C – +55°C, 95% RH, 2 cycles
Vibration	See datasheet
Housing material	Plastic, See datasheet for details
Protection class	IP20
Product weight	150 g
Dimensions	27 x 144 x 98 mm (W x H x D) with connectors included
Mounting	DIN-rail